

# The effect of feeding position and body size on the capacity of small ruminants to reach for food when fed through barriers

<sup>1</sup>Muhikambele\*, V. R. M., N. F. Massawe<sup>2</sup>, L. A. Mtenga<sup>1</sup>, E. A. Butler<sup>3</sup> and E. Owen<sup>3</sup>

<sup>1</sup>Department of Animal Science and Production, Sokoine University of Agriculture, PO Box 3004, Morogoro, Tanzania

<sup>2</sup>Selian Agricultural Research Institute, PO Box 6024, Arusha, Tanzania

<sup>3</sup>Department of Agriculture, The University of Reading, Earley Gate PO Box 236, Reading RG6 6AT, UK

## Abstract

*Small ruminant systems, especially with intensification in the tropics, are increasingly involving indoor stall-feeding. To facilitate manger design, there is a need for information on the ability of the animal to reach for food, such as that available for cattle fed through barriers. Thirty eight goats (20 Galla, mean weight 28.2 kg, 18 Small East African; mean weight 24.6 kg) and 26 sheep (16 Blackhead Persian, mean weight 24.0 kg, 10 Red Maasai; mean weight 20.4 kg), were trained to reach for concentrate meal placed on a horizontal platform through a vertical tombstone barrier. The barrier allowed the neck to pass through, but not the shoulders. It was hypothesized that goats would have larger reach than sheep and that for each species, horizontal reach forwards, F, (distance from mid-point of barrier to uneaten meal) and sideways, S, (distances sideways from mid-point of barrier to uneaten meal adjacent to barrier) would be a function of height of platform above the floor (0, 15, 30 and 45 cm) and body size (weight and linear measurements, e.g. body length). Goats had significantly larger F and S values than sheep. Mean values for F at platform heights 0, 15, 30 and 45 cm were 37.9, 41.8, 44.7 and 39.4 cm respectively for sheep and 45.4, 46.6, 47.2 and 43.0 cm respectively for goats. Values for S were smaller, but followed a similar pattern. Linear correlation coefficients between F or S and dimensions in sheep were all low (0-0.5), but in goats, especially for F, correlations were generally high (0.4-0.8). Except for the low correlation between reach and size in sheep, the results supported the hypotheses. The data will facilitate manger design for small ruminants of similar breeds, having dimensions in the range of those used in the study.*

**Key words:** Reach for food, sheep, goats, barriers, body dimensions

## Introduction

Production systems World-wide almost invariably involve the housing and feeding of goats and sheep indoors during part or all of their production cycle (Trodahl et al., 1981; Coop and Devendra, 1982; Devendra and Burns, 1983; Wilkinson and Stark, 1987; Mowlem, 1988; Gatenby, 1991; Croston and Pollott, 1994). Furthermore, feeding small ruminants in permanent confinement is increasing in tropical smallholder agriculture because of the integration of crop and animal enterprises (McIntire et al., 1992). In addition, there is an

emergency of non-grazing systems to allow pasture regeneration following overgrazing which has been widespread (Ogle et al., 1996) and peri-urban milk production (Rey et al., 1993) and these necessitate the confinement of animals. In view of this, it is surprising that there appears to be no published research on the design of feeders for either goats or sheep. Casual observation of the eating behavior of both goats and sheep shows them to reach for food offered in mangers many times leaving substantial quantities untouched. Apart from the study by Muhikambele (1993), there are no published

\*Corresponding author

data on reach such as those reported in cattle given access to feed through tombstone barriers (Versbach, 1970; Gjestang, 1983; Petchey and Hailu, 1993). As pointed out by Zappavigna (1983), reach is one of the important factors for consideration when designing mangers for live-stock offered food through barriers. For cattle, tombstone barriers are normally upright concrete slabs, which allow the neck, but not the head to pass between adjacent slabs. Thus the animal has to lift its head over the barrier and lower it down to the feed.

The present study was, therefore, undertaken to provide base-line data on the ability of tropical goats and sheep to reach for food through a tombstone barrier. Since goats are browsers and sheep are grazers (Devendra and McLeroy, 1982; Coop and Devendra, 1982), it was hypothesized that goats would have a greater reach than sheep. For both species, it was also hypothesized that horizontal reach, both forwards and sideways, would be a function of the height above ground at which the food was offered in a horizontal plane. Furthermore, in both goats and sheep, it was hypothesized that the ability to reach for food would be a function of body size. Under normal circumstances, animal size increases with age up to a certain limit. However, in some circumstances, for example, under poor management, old animals may have smaller sizes than younger ones that have been well managed. Thus in the present study, age was not considered important as a factor of reach since the animal's size, particularly head and neck length and height at withers, which seem to be much involved in the animal's reach for food are not necessarily correlated with age.

## Materials and methods

A total of 38 non-pregnant goats (20 Galla and 18 Small East African) and 26 non-pregnant sheep (16 Blackhead Persian and 10 Red Maasai) were used. The 64 animals were allowed to adapt to indoor housing and indoor feeding for 28 days. For the 28 days prior to and during the subsequent four-day reach-assessment period, sheep were penned individually and offered grass hay *ad libitum* (allowed to refuse 15% of amount offered) and a

concentrate meal at 20 g dry matter (DM)/kg metabolic body mass ( $M^{0.75}$ ) daily. The concentrate comprised 400 g/kg maize bran, 300 g/kg rice polishings, 250 g/kg sunflower cake and 50 g/kg vitamin-mineral premix. Hay and concentrate were offered at 0900 and 1600 h in ground-level mangers which were accessed by the animals by placing their heads and necks through a wooden tombstone barrier placed between the pen and the manger. For two, 30-minute periods (one during 10.00 to 12.00 h, another during 14.00 to 16.00 h) on five consecutive days before assessing reach, each animal was placed in an 'assessment pen' and trained to put its head and neck through a wooden tombstone barrier and reach for 10 g DM per kg  $M^{0.75}$  of a concentrate meal spread evenly on the surface of a horizontal, calibrated 1m<sup>2</sup> platform measuring 1.0 x 1.0 m (Figure 1). To ensure readiness to eat, the animals were not offered concentrate in the mangers on training and reach-assessment days. The procedure adopted, that is, training and assessment, was based on an earlier study by Muhikambele (1993) which had established that a five-day training period was sufficient for animals accustomed to being housed. Furthermore, it was not possible to exceed two assessments per individual animal daily as this would result in the amount of concentrate offered being in excess of the rate of supplementation (20 g DM/kg  $M^{0.75}$  per day).

Live weight was recorded on days 1, 2 and 3 of the reach-assessment period and the mean weight was used to define the body weight ( $M$ ) for each animal. Weighing was done immediately before undertaking reach assessment. On day 1, triplicate measurements of linear body dimensions were also made and the mean was used for a given dimension and animal. Each of the body dimensions was measured once and then the whole procedure repeated twice; the total time required was about 30 minutes per animal. Height measurements were made in a vertical plane using a measuring rod which incorporated a spirit level. All other measurements were made using a plastic tape. The following body dimensions were recorded: heart girth: measured in a vertical plane, directly behind the front legs and with legs in a vertical position; withers height: distance between the floor and

the highest point on the back, at the dorsal edge of the scapula bones; knee height: distance between the floor and the mid-point of the patella; sternum height: distance between the floor and the ventral surface of the sternum; rump height: distance between the floor and the dorsal edge of the pelvic girdle; neck length: distance between the anterior edge of the first cervical vertebra and the posterior edge of the last cervical vertebra; and body length: distance between the anterior edge of the first thoracic vertebra and the last sacral vertebra.

Both the forwards (F, the distance from the mid-point of the barrier to uneaten meal) and sideways (S, the mean of the distances sideways, left and right, from the mid-point of the barrier to uneaten meal adjacent to the barrier) horizontal reach for 10 g DM per kg  $M^{0.75}$  concentrate meal, for each animal, were measured with the feeding platform set at 0, 15, 30 and 45 cm above floor level (Figure 1). Reach at each height was measured in duplicate. The larger

value was used in data analysis because the objective was to measure maximum reach. This approach was adopted because the earlier study by Muhikambele (1993) showed that animals occasionally did not show maximum reach. The order of undertaking the eight reach measurements (four platform heights, in duplicate) was random, with two measurements being made daily, one in the morning and one in the afternoon. The barrier width was adjusted for each animal to allow the neck to pass through, but not the shoulders. Reach assessments were undertaken on batches of four animals in any one four-day period. Selection of animals (irrespective of species) for each batch was at random. Data were subjected to statistical analyses using a General Linear Model (GLM) and Regression (REG) procedures (Statistical Analysis Systems Institute, 1989). Analyses included body weight as a covariant. A split-plot model was used for the statistical analysis using SAS where 'species' and 'breed' formed a main plot part, using

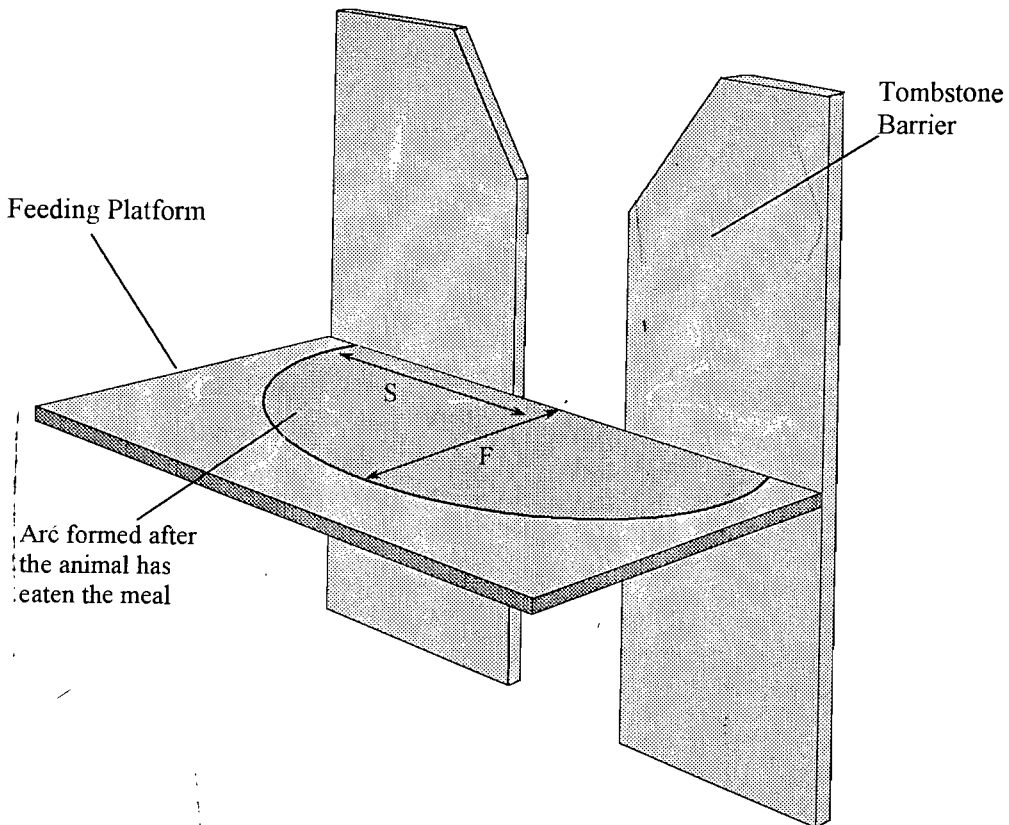

Figure 1. Measurements of forward (F) and sideways (S) reach for sheep and goats

'animals within species' as its error term (error [a]) and 'platform height' formed a split plot part using an overall model error (error [b]). As the results indicated a non-significant effect of breed within species, "breed" was, therefore, ignored in the analysis. For both goats and sheep, multiple range tests were run to compare forwards and sideways reach at different feeding-platform heights.

Simple linear regression analyses were used to relate reach with body size (weight and linear measurements) viz.:

'REACH' =  $a + bx$ , where 'a' is constant (intercept), 'b' is a regression coefficient (slope) and  $x$  is body weight or linear body dimension.

## Results

Goats had significantly longer reach than sheep, both forwards and sideways (Table 1). For sheep, reach forwards increased ( $P < 0.05$ ) with increasing height of feeding platform from

0, 15 and 30 cm. As in sheep, increasing the platform height to 45 cm out of 26 sheep and 32 out of 38 goats knelt to reach for food when eating at 0-cm platform height.

There was a difference between sheep and goats in the correlation coefficients from the simple linear regression of horizontal reach, both forwards and sideways, on body weight and linear dimensions (Table 2). In sheep, correlations were low ( $P > 0.05$ ) at all platform heights. However, in goats, correlations were high for body weight ( $P < 0.05$ ) and for most linear dimensions, except sternum height and sideways reach at 45 cm.

## Discussion

The results support the hypothesis that reach is larger in goats than sheep. A longer reach in goats compared to sheep was also recently found by Muhikambele (1993), working with

**Table 1: Mean ( $\pm$ se) forwards and sideways reach for sheep and goats at four platform heights**

		Sheep	Goats
Number of animals		26	38
Mean body weight $\pm$ SD (kg)		22.6 $\pm$ 3.25	26.5 $\pm$ 6.33
Range of body weight (kg)		19.2 - 33.0	11.2 - 41.0
	Platform height (cm)		
Forwards reach (cm)	0	37.9 <sup>a</sup> $\pm$ 1.33	45.4 <sup>a</sup> $\pm$ 0.61
	15	41.8 <sup>b</sup> $\pm$ 0.85	46.6 <sup>a</sup> $\pm$ 0.87
	30	44.7 <sup>c</sup> $\pm$ 0.97	47.2 <sup>a</sup> $\pm$ 0.75
	45	39.4 <sup>a</sup> $\pm$ 1.06	43.0 <sup>b</sup> $\pm$ 0.83
	Mean	40.9 $\pm$ 0.58	45.5 $\pm$ 0.40
Sideways reach (cm)	0	35.7 <sup>a</sup> $\pm$ 0.98	41.0 <sup>a</sup> $\pm$ 0.55
	15	39.5 <sup>b</sup> $\pm$ 0.75	42.7 <sup>b</sup> $\pm$ 0.66
	30	40.1 <sup>b</sup> $\pm$ 0.93	42.9 <sup>ab</sup> $\pm$ 0.55
	45	35.6 <sup>a</sup> $\pm$ 1.13	39.6 <sup>b</sup> $\pm$ 0.81
	Mean	37.7 $\pm$ 0.52	41.4 $\pm$ 0.34

For each of forwards and sideways reach, means within columns with different superscripts are significantly different ( $P < 0.05$ ).

0 to 30 cm, but at 45 cm, reach decreased and was comparable to that at 0 cm. There was a similar pattern for sideways reach in sheep, except that reach at 15 and 30 cm were similar ( $P > 0.05$ ). For goats, reach forwards was simi-

larger, temperate genotypes such as Saanen goats and Suffolk cross Mule sheep in the UK. The present study showed sheep, and to a lesser extent goats, to have longer reaches when plat-

form height increased above floor level, and that reach was shorter when platform height was highest (45 cm). This supports the hypothesis that height of feeding platform affects capacity to reach. It is notable that when the feeding platform was at floor level (0 cm), the majority of animals (73% of sheep, 84% of goats) knelt when feeding. Presumably, this was an attempt to increase their capacity to reach.

The increase in reach on raising the feeding platform above floor level compares with reach studies in cattle fed through tombstone barriers. Versbach (1970) showed longer horizontal reach in cattle when concentrate was offered at

level to 13.5 cm. Further increases in reach occurred at feeding heights of 27 and 40 cm, but wastage also increased. The results of the present study, showing goats and sheep to have longer horizontal reach forwards than sideways, are in agreement with those of Muhikambele (1993) for goats and sheep and Versbach (1970) for cattle. Versbach (1970) suggested maximum forwards and sideways reach to be 90-100 and 55 cm, respectively.

The results for goats (Table 2) clearly support the hypothesis that reach is a function of animal size. There is no explanation why the data for sheep showed such lower estimates of

**Table 2: Linear correlation coefficients (r) between reach and body weight (kg) and linear body dimension (cm) in sheep and goats**

Platform height(cm)	0	15	30	45	0	15	30	45
	Forward				Sideways			
<b>Sheep</b>								
Body weight	0.10 NS	0.22 NS	0.00 NS	0.21 NS	0.05 NS	0.10 NS	0.12 NS	0.25 NS
Heart girth	0.06 NS	0.05 NS	-0.02 NS	0.16 NS	-0.05 NS	-0.05 NS	0.07 NS	0.21 NS
Withers height	0.15 NS	0.01 NS	0.06 NS	0.41 NS	0.01 NS	-0.15 NS	0.20 NS	0.31 NS
Knee height	-0.11 NS	0.00 NS	-0.10 NS	0.15 NS	-0.21 NS	0.04 NS	-0.11 NS	0.05 NS
Sternum height	0.01 NS	-0.19 NS	-0.06 NS	0.19 NS	-0.02 NS	-0.25 NS	-0.06 NS	0.09 NS
Rump height	0.10 NS	0.02 NS	0.08 NS	0.25 NS	-0.04 NS	-0.04 NS	0.19 NS	0.21 NS
Neck length	0.05**	0.42*	0.24 NS	-0.14 NS	0.20 NS	0.29 NS	0.19 NS	0.05 NS
Body length	0.35	0.07	-0.08	-0.08	0.13 NS	-0.10 NS	0.05 NS	0.06 NS
<b>Goats</b>								
Body weight	0.76***	0.73***	0.80***	0.66***	0.60***	0.72	0.72***	0.49***
Heart girth	0.80***	0.73***	0.76***	0.73***	0.65***	0.72	0.68***	0.55***
Withers height	0.68***	0.56***	0.70***	0.58***	0.56***	0.58	0.70***	0.37*
Knee height	0.64***	0.59***	0.73***	0.59***	0.56***	0.63	0.73***	0.42*
Sternum height	0.59***	0.40*	0.57**	0.49**	0.55***	0.43	0.57*	0.29NS
Rump height	0.73***	0.57***	0.74***	0.62***	0.61***	0.60	0.70***	0.39*
Neck length	0.74***	0.57**	0.68***	0.56***	0.68***	0.56	0.60**	0.47**
Body length	0.71***	0.71***	0.72***	0.64***	0.60***	0.70***	0.71***	0.47**

NS=Not significant, \* = Significant at 5% level of significance, \*\* = Significant at 1% level of significance, \*\*\* = Significant at 0.1% level of significance

40 cm above ground rather than at ground level. Gjostang (1983) reported 'easier access' to feed offered at 10 to 20 cm above ground rather than at the ground level in dairy cows. Petchey and Hailu (1993) also found that reach for hay increased and wastage decreased, when the feeding height for cattle was raised from ground

correlation between reach and body dimensions. Using similar methods, Muhikambele (1993) found higher estimates of correlation than in the present study between forward reach and body dimensions in temperate goats. Although Muhikambele's (1993) estimates of correlation

were lower in sheep than in goats, the correlation estimates in sheep were much larger than in the present study.

## Conclusions

For each of the two breeds of sheep and goats used, the study shows that ability to reach for food through barriers increases with increasing feeding-platform height, up to 30 cm above floor level, and thereafter decreases. Irrespective of feeding-platform height, the study shows that goats have longer reach than sheep. Furthermore, reach in goats is highly correlated with body size; this is less apparent in sheep. The results of the study will be of use in the design of mangers for small ruminants with body dimensions of similar range. The results also point to the need to accommodate reach differences between sheep and goats. Based on the study, a feeding platform height of 30 cm may be recommended for the best reach by sheep and perhaps a slightly higher height (35-40 cm) for goats.

## Acknowledgements

The authors wish to acknowledge the Norwegian Agency for Development Cooperation (NORAD) for financing the study.

## References

Coop, I.E. and Devendra C., 1982. Systems, Biological and Economic Efficiencies. In: I.E. Coop (Editor), Sheep and goat production, Elsevier Scientific Publishing Company, Amsterdam, pp. 297-307

Croston, D. and Pollott, G., 1994. Planned sheep production. Blackwell Scientific Publications, Oxford, 207 pp.

Devendra, C. and Coop, I.E., 1982. Ecology and Distribution. In: Coop, I.E. (editor), Sheep and goat production, Elsevier Scientific Publishing Company, Amsterdam, pp. 1-14.

Devendra, C. and McLeroy, C. B., 1982. Goat and sheep production in the tropics. Intermediate Tropical Agriculture Series. Longman, London, 271 pp.

Devendra, C. and Burns, M., 1983. Goat production in the tropics. Second Edition. Commonwealth Agricultural Bureaux, Slough, 183 pp.

Gatenby, R. M., 1991. The tropical agriculturalist: Sheep. Macmillan Education Ltd., London and Basingstoke in co-operation with CTA (Technical Centre for Agricultural and Rural Co-operation), Wageningen, 154 pp.

Gjestang, K., 1983. Feeding table geometry for dairy cows. Transactions of American Society of Agricultural Engineers, 26:890-892.

McIntire, J., Bourzat, D. and Pingali, P., 1992. Crop-livestock interaction in Sub-Saharan Africa. The World Bank, Washington D.C., 246 pp.

Mowlem, A., 1988. Goat farming. Farming Press, Ipswich, 183 pp.

Muhikambele, V.R.M., 1993. Measurement and prediction of capacity to reach for food through barriers in sheep and goats: effect of body size on horizontal and vertical reach in castrates and females. Ph.D. Thesis, University of Reading, UK, 311 pp.

Ogle, R.B., Wiktorsson, H. and Masaoa, A.P., 1996. Environmentally sustainable intensive livestock systems in semi-arid central Tanzania. In: R.L. Kurwijila et al. (Editors) Proceedings of the 29<sup>th</sup> Scientific Conference of the Tanzania Society of Animal Production, 20:90-96.

Petchey, A. M. and Hailu, T., 1993. The effect of varying cattle trough height on their reach and food wastage. Animal Production, 56:457 (Abstr.).

Rey, B., Thorpe, W., Smith, J., Shapiro, B., Osuji, P., Mullins, G. and Agyemang, K., 1993. Improvement of dairy production to satisfy the growing consumer demand in sub-Saharan Africa: A conceptual framework for research. Market-Oriented Small Dairying Research Working Document 1. International Livestock Centre for Africa (ILCA), Addis Ababa, Ethiopia, 13 pp.

Statistical Analysis System Institute, 1989. SAS/STAT User's guide, Version 6, Fourth edition, volume 2. SAS Institute, Inc., Cary, NC. 956 pp.

Trodahl, S., Skjvedal, T. and Steine, T.A., 1981. Goats in cold and temperate climates. In: C. Gall (Editor) Sheep production. Academic Press, London, pp. 489-513.

Versbach, M., 1970. Technik und Verfahren der Einzeltierfütterung im Rindviehlaufstall (Techniques and procedures for feeding individual animals in loose-housed cattle). KTBL Berichte über landtechnik no. 239, 182 pp.

Wilkinson, J. M. and Stark, B. A., 1987. Commercial goat production. BSP Professional Books, Oxford, 159 pp.

Zappavigna, P., 1983. Space and equipment requirements for feeding in cattle housing. In: S.H. Baxter et al. (Editors), Farm animal housing and welfare. Martinus Nijhoff Publishers, The Hague, pp. 155 -163.