

QUANTITY, RESOLUTION, AND SYLLABLE GEOMETRY

Roger Lass

1 Syllable constituency¹⁾

I want to argue in this paper that a quite simple constituency model for syllabic structure, plus assumptions about the placement of boundaries, can bring together some apparently unrelated phenomena in a satisfying way. Among these are aspects of Old English noun morphology, the phonotactics of Swedish, the nature of the neutralization of quantity in North Germanic, two apparently 'aberrant' types of alliteration-bearing syllables in Old Germanic verse, and the problem of the moric structure of 'short' diphthongs in Old English and elsewhere.

There is nothing really new in the model; though some of the arguments are as far as I know original, and the model is simpler than some that have recently been proposed.²⁾ I will not enter into any discussion of the justification for the syllable itself as a phonological prime; I assume this is no longer a theoretical problem, and that recent discussion (Hooper 1972, 1976, Anderson & Jones 1974, Allen 1973, Árnason 1980) has restored this traditional notion to a central position, and defused earlier arguments (e.g. Kohler 1966) against the necessity or desirability of the syllable.

But I do want to spend some time on arguments for the syllable as a hierarchically structured unit, in particular one with at least three (and possibly more: cf. §4 below) levels or 'tiers' that are theoretically independent --- not merely a linear bracketing. Using terminology that is by now familiar, let us say that a syllable (σ) consists of two major constituents, an Onset (O) and a Rhyme (R), and that the latter consists of a Peak (P) and a Coda (Co):

(1)

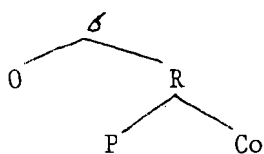

Of these constituents, only P is obligatorily filled; O, Co may be null. That is, P defines 'syllable', in that it is the bearer of whatever segment carries syllabicity. We may conceive if we wish a syllable as a structure generated by a simple PS grammar of the type:

- (2)
- (i) $\sigma \rightarrow O R$
 - (ii) $R \rightarrow P Co$
 - (iii) $P \rightarrow \left\{ \begin{array}{l} V_1^3 \\ C_1^2 \end{array} \right\}$
 - (iv) $O \rightarrow C^k$
 - (v) $Co \rightarrow C^k$

In (2)(iii), V_1^3 allows for anything from a short to an 'overlong' vowel (as in Estonian); C_1^2 allows for short or long syllabic consonants. (I operate under the assumption that 'length' is essentially a moric phenomenon --- more on this below). The superscript k in (iv)-(v) is a language-specific maximal cluster size. If one wanted to, one could specify onsets and codas further in terms of segment types --- but this is best done on a language-specific basis.³⁾

2 Light and heavy syllables in Germanic

The first problem is justifying this particular constituency: what is the evidence for rhymes as two-tiered? I will approach this somewhat indirectly, through a discussion of syllable quantity in Old English and North Germanic. I begin in what is apparently an odd place, with the morphology of Old English nouns. Consider the following forms:

- | | | | |
|-----|---------------------------------------|---|---|
| (3) | | A. | B. |
| (i) | Neuter <u>a</u> -stem, nom/
acc pl | fæt-u 'vessels'
hof-u 'dwellings'
lim-u 'limbs' | wīf 'woman'
dēor 'animals'
word 'words' |

	A.	B.
(ii) Neuter <u>a</u> -stem di-syllables, nom sg vs. gen sg	wæter/wæter-es 'water' gamen/gamen-es 'game' ofet/ofet-es 'fruit'	ātor/ātr-es 'poison' bēacen/bēacn-es 'beacon' tungol/tungl-es 'star'
(iii) <u>ō</u> -stem, nom sg	win-e 'friend' hef-e 'weight' hyp-e '(rose)hip'	glæm 'gleam' liæg 'flame' ent 'giant'
(iv) Masc <u>u</u> -stem, nom sg	sun-u 'son' breg-u 'prince' lag-u 'sea'	gār 'spear' sēap 'pit' feld 'field'

It is clear that there is a parallel between stems with long vowels and stems with 'long' diphthongs. (Old English seems to have had a long/short diphthong contrast, which I will return to in §5; for now a 'long' diphthong is what is usually understood as a diphthong, i.e. a vowel-cluster behaviorally parallel to a long vowel). If we take diphthongs uncontroversially as V_1V_2 sequences, then we can take long vowels as V_1V_1 , i.e. as 'geminate', and both types can be represented as VV .⁴⁾

Given this, the generalization is clear; taking the forms in (3)(i), (iii)-(iv), column A vs. B, there seems to be a phonologically conditioned alternation:

- (a) if the stem ends in -VC, there is a suffix;
- (b) if the stem ends in -VVC or -VCC, there is no suffix.

And for the disyllables in (ii):

- (c) if the first syllable of a disyllabic sonorant-final stem is -VC, the second vowel does not syncopate when another syllable is added;
- (d) if the first syllable ends in -VVC or -VCC, then the second vowel syncopates.⁵⁾

The two are clearly related: -VVC and -VCC trigger the same sort of

- (6) Light Syllable ($\check{\sigma}$): neither R constituent branches,
though R itself may branch.
Heavy Syllable ($\bar{\sigma}$): at least one R constituent branches.

We can thus distinguish *length* (a moric property of constituents of R) from *quantity* (a configurational property of R itself).⁶⁾

Given only this much data, however, we could still argue that quantity is a sequential rather than hierarchical property: if the equivalences are $VVC \equiv VCC \neq VC$, then a heavy syllable could be defined as having at least two segments to the right of the first V. But as we will see in §2, *VV alone* also belongs to the same class as *VVC, VCC*. In anticipation, the class of heavy rhymes can be given as:

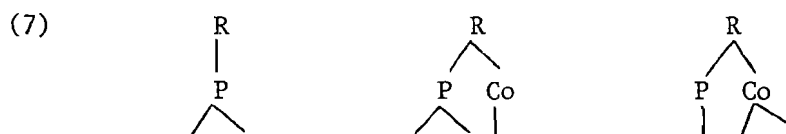

And we would predict (see below) that (8) would also count as heavy:



This is a so-called 'overlong' or *hypercharacterized* rhyme.

For the present, then, if we take a three-tier constituency structure as reasonable ($\check{\sigma}$, (R), (P, Co)), quantity is defined solely on the (P, Co) tier, in terms of one configurational primitive: branching. A heavy syllable is one where either P or Co (or in the extreme case both P, Co) branches.⁷⁾

This configurational approach provides a useful notation for stating syllable structure constraints for certain types of languages. Thus in modern West Germanic (except Yiddish), a final stressed syllable must contain at least a long vowel or diphthong, or VC; legal stressed final rhymes are:

(9)

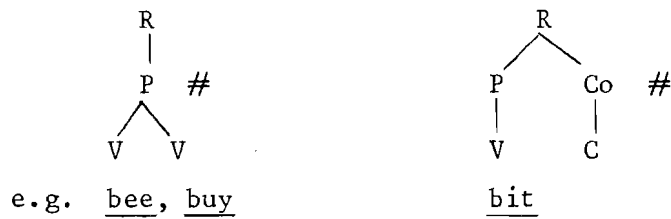

We can then define legal stressed final rhymes negatively, in terms of a phonotactic filter:

(10)

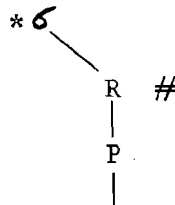

So for West Germanic, no rhyme that does not branch, *or* contain at least one branching constituent, may stand in stressed final position.

We now turn to some languages with more restrictive syllable structure conditions, which clarify the differential status of the two tiers themselves, and of P and Co within R.

Modern English no longer makes the light/heavy distinction on the phonotactic level --- though it is relevant for stress placement.⁸⁾ But some Germanic languages still do, notably all the Scandinavian ones except Danish. These have --- in general --- a system restricting accented syllables to the heavy type alone; and in particular, to a subset of the heavy types in (7)-(8).⁹⁾

Thus in modern (standard) Swedish, we have the following possibilities for stressed syllables:

(11)

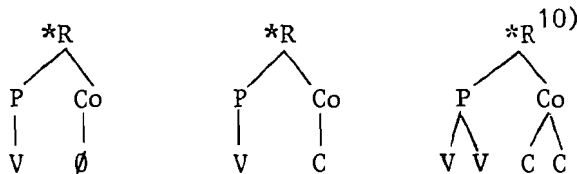
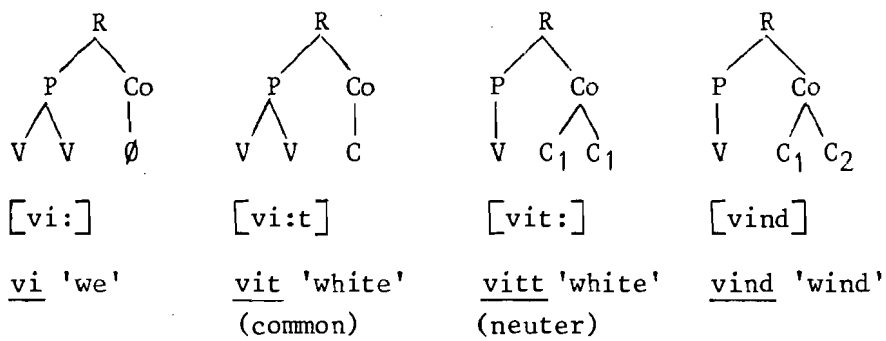

It is clear from vitt, vind that consonant length as well can have a natural moric interpretation. (The boundary in vitt = /vit+t/ is irrelevant; the same condition holds for monomorphemic forms, e.g. väg [vɛ:g] 'way' vs. vägg [vɛ:g:] 'wall'.)

It is worth noting here that the distinction made in §1 between simple heavy and hypercharacterized rhymes in terms of single vs. double branching within R is borne out by Swedish. Here we are allowed to have fairly heavy post-peak clustering (up to four Cs in Co); but only if the vowel is short. Thus forms like svenskt 'Swedish (neuter)', spotskt 'scornful (neuter)' are well formed: i.e. a complex or multiply branching coda is simply one possibility for a heavy rhyme, provided P does not branch. Compare:

(12)

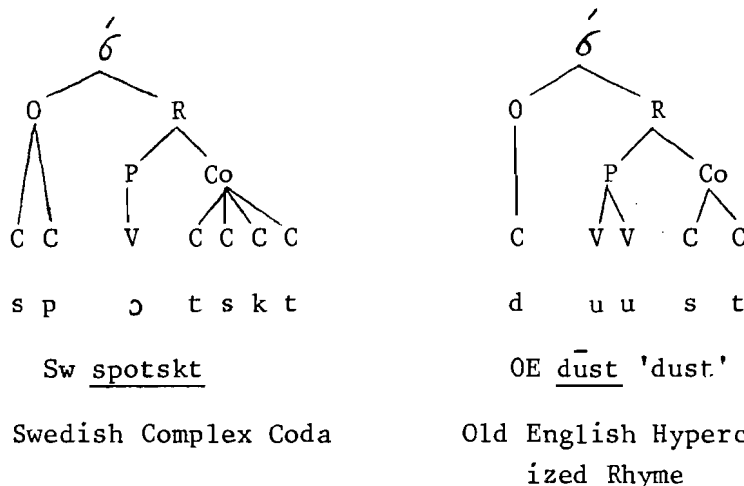

This would argue against assigning the second mora of a complex peak to Co, as suggested in (McCarthy 1979) --- at least for languages like Swedish; this would fail to distinguish between legal and illegal rhyme types. Hypercharacterization, that is, is not a linear or additive notion, but a hierarchical one: a multiply branching Co is not equivalent to two branching constituents, even if the same number of segments happens to be involved.

The distinction shows up nicely in the history of North Germanic, in various changes leading to the present distribution of quantity. The old Scandinavian languages allowed five stressed rhyme types --- here represented by Old Icelandic forms: ¹¹⁾

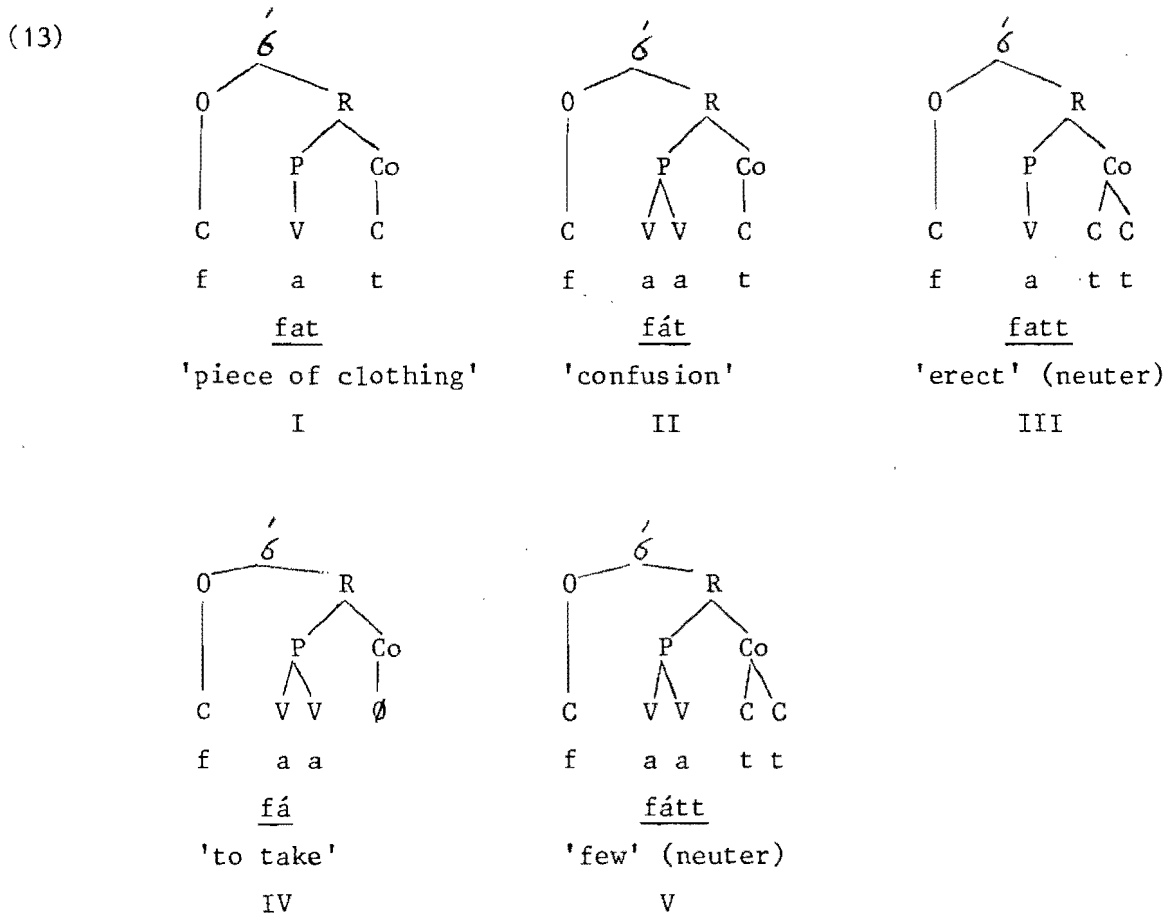

Swedish, Norwegian, Icelandic, Faroese eliminated types I and V; and the strategies by which this was accomplished are interesting, and lend support to the branching analysis. Take the verb flétta 'to plait' (here given in Old Icelandic, but its cognates survive in Swedish, which

is our concern here). The rhyme of the first syllable is hypercharacterized VVCC. In modern Swedish we get two forms: /flɛt:a/ in Värmland and the north, and /fle:ta/ in Stockholm and the central dialects. This looks like a matter of two possible implementations of an overall constraint or 'metarule' (Lass 1976:ch. 2):

- (14) Hypercharacterization Adjustment: Only one R-constituent may branch.

Implementation:

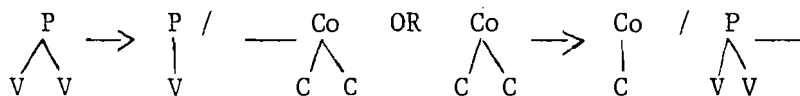

This is the first stage in a general loss of phonemic quantity: paring away the over-heavy syllable type.¹²⁾ The next stage is to get rid of light VC rhymes. Here there are two strategies, essentially inverses of the two options in (14): lengthening of short vowels before one C, and lengthening of consonants after short vowels. As far as we can tell, the two tendencies were regionally favoured in Swedish, like the ways of eliminating VVCC: vowel lengthening predominates in the south, and consonant lengthening in the north. In modern standard Swedish, we find a confluence of the two types (much as we find both northern and southern features in London-derived modern standard English). In the end all that matters, for the canonical syllable shape of a given dialect, is that all stressed rhymes be heavy --- not how they get that way, or what the distribution of VVC vs. VCC is.¹³⁾

Thus compare the developments of OSw skip 'ship', spur 'trace', modern skepp, spår:

(15)

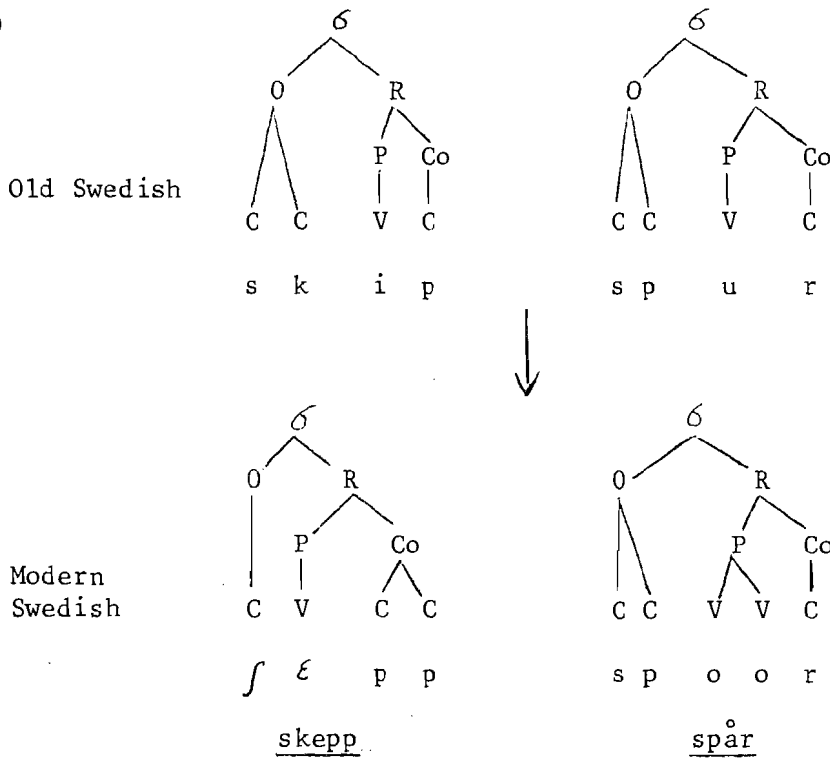

So we have another metarule operating:

(16) Canonical Stressed Rhyme: at least one R-constituent must branch.

Implementation:

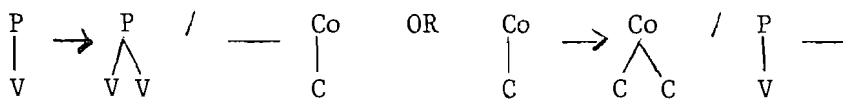

Conditions (14, 16) together define the shape of the Scandinavian 'Quantity Shift', and define synchronic legal rhyme shapes.

3 Syllable boundaries and derived heavy rhymes

Old Germanic verse in general (the 'classical' type, not that influenced by mediaeval Latin or Romance verse-forms) is written in an alliterative line, whose organizing principle is the binding together of two half-lines by two or more alliterating syllables, at least one in each hemistich.

The alliterating syllables (Hebungen, 'lifts') must (a) be accented at word level, (b) generally belong to categories that carry sentence or phrase accent (e.g. major lexical categories, primarily nominal), and (c) be heavy.¹⁴⁾ The definition of heavy syllable in Germanic verse is not the same as that in Latin: in the latter case, branching at any level seems to be sufficient to make a syllable metrically heavy (Hale & Buck 1903 [1966]: Part V, Allen 1965:ch. 6, Allen 1973:130f).¹⁵⁾

The most 'normal' type of Old English line, for example, counts as heavy only those syllables with branching at the P, (Co) tier, i.e. -VV(C), -VCC. Some characteristic examples from Beowulf (Klaeber 1950; alliterating syllables italicized):

(17)

- | | | | | |
|-----|--------------------|--------------------|--------------|-------------------------|
| | | VVC | | VVC |
| 1. | Hwæt, we | <u>gar</u> -Dena | in | <u>gear</u> -dagum |
| | | VV | VCC | VVC |
| 6. | <u>fēa</u> -sceaft | <u>funden</u> | he | þæs <u>frōfre</u> gebad |
| | VCC | VCC | | VVC |
| 11. | <u>gomban</u> | <u>gyldan</u> | þæt wæs | <u>god</u> cyning |
| | | VCC | VCC | |
| 22. | þæt hine on | <u>ylde</u> | <u>eft</u> | gewunigen |
| | VVC | VCC | VCC | |
| 31. | <u>leof</u> | <u>land</u> -fruma | <u>lange</u> | āhte |

But not all alliterating lifts are of this type: there are two others, which are of considerable interest. In the first, we apparently have --- on first inspection --- a -VC rhyme occupying a lift. Such occurrences are not discussed in the handbooks in any detail, and when they are mentioned tend to be brushed aside with remarks like 'the *arsis* (or rhythmic stress) requires a long syllable (the vowel must be long in quantity, or, if short, the syllable must be closed with a consonant' (Hulbert 1935:229). Taken literally, this would imply that words like God 'God', þrym 'power', hron 'whale', mid 'with' could serve as lifts, just like the characteristic long syllables in (17), or Latin dat, quid.

This is not however the case. Forms like these *can* occupy lifts, but only under special conditions. As far as I can determine, a -VC rhyme can occupy a lift just in case the next word in the line begins with a

consonant. Some examples, again from Bēowulf (the cases in question are notated VC C) are:

- (18)
- | | | |
|-----|---|---|
| 2. | $\overline{\text{VVC}}$
<u>ƿeod-cyninga</u> | $\overline{\text{VC C}}$
<u>ƿrym gefrunon</u> |
| 10. | $\overline{\text{VC C}}$
ofer <u>hron-rade</u> | $\overline{\text{VVC}}$
<u>hyran</u> scolde |
| 13. | $\overline{\text{VCC}}$ geong in $\overline{\text{VCC}}$ <u>geardum</u> | $\overline{\text{VC C}}$
ƿone <u>God sende</u> |
| 25. | $\overline{\text{VVC}}$
in <u>mægþa</u> gehwære | $\overline{\text{VC C}}$
<u>man geþeon</u> |
| 50. | $\overline{\text{VCC}}$
<u>geongum</u> ond ealdum, | $\overline{\text{VC C}}$
swylc him <u>God sealde</u> |

Two points are significant: (a) whenever -VC counts as heavy, there is a C following in the next word; (b) it is frequently the case that the -VC C sequence is not phonotactically legal in syllable-final position in Old English. Thus the examples in (18) give */mj/, */nr/, */ds/, */nj/. Examination of other texts for the same phenomenon yields legal /lm/ (Leiden Riddle 11), */mt/ (Cott. Tib. B.i Gnostic Verses, 20, 32), */ts/ (ibid. 22). */nw/ (ibid. 8), and so on. (Texts in Sweet-Whitelock 1967).

Now if -VC counts as heavy only if the next word begins with a consonant,¹⁶⁾ this suggests that it is that consonant which is defining the heaviness. It is treated as if it belonged, not to the onset of its own syllable, but to the coda of the preceding one, even if a word boundary intervenes. If this phenomenon were very sporadic, or restricted to a few texts, preferably by the same author or from the same dialect tradition, it could be dismissed as a permissible solecism for cases of metrical desperation. But in fact it is quite widely distributed, and not only in Old English.

In Old Saxon, for instance, we find the same thing --- though apparently less frequently than in Old English. From Heliand (Markey 1976):

- (19)
- | | | |
|------|--|---|
| 138. | an is $\overline{\text{VC C}}$
<u>bod-skepi</u> | $\overline{\text{VVC}}$
<u>beþe</u> quāmin |
|------|--|---|

154. is unca $\overline{\text{VC C}}$ lud geliden $\overline{\text{VVC}}$ līk gidrusnod
169. hebbēan thīnaro $\overline{\text{VCC}}$ stemna giuuald; ni tharft thū $\overline{\text{VC C}}$ stum uesan
176. bihuuī hē thar sō $\overline{\text{VCC}}$ lango $\overline{\text{VC C}}$ lof-salig man

This kind of lift can be formed, apparently, even out of consonants across a sentence boundary, at least in Old English. Thus (Cotton Gnostic Verses):

(20)

20. $\overline{\text{VVC}}$ toð-mæ genes $\overline{\text{VC C}}$ trum. Til sceal on ēble
32. $\overline{\text{VVC}}$ tīr-fæste getrum. $\overline{\text{VC C}}$ Trēow sceal on earle

In Old High German, examples are rarer (due perhaps to the relatively large amount of rhyming verse in the corpus), but they do occur:

(21) a. Hildebrantslied (Klaeber 1950):

7. $\overline{\text{VCC}}$ Hiltibrant gimahalta (Heribrantes¹⁷) sunu) $\overline{\text{VC C}}$ her uas
heroro man
55. $\overline{\text{VC C}}$ Doh maht $\overline{\text{VV}}$ dū nu aodlihho, $\overline{\text{VC CVVC}}$ ibu dir dīn ellen taoc
59. der dir nū $\overline{\text{VVC}}$ wīges $\overline{\text{VCC}}$ warne, nu dih es sō $\overline{\text{VC C}}$ wel lustit

b. Wessobrunner Gebet (Naumann & Betz 1967:143)

- $\overline{\text{VVC}}$ cootlihhe geista $\overline{\text{VC C}}$ enti cot heilac

c. Muspilli (Naumann & Betz: 152)

33. $\overline{\text{VCC}}$ deyme ni kitar parno nohhein $\overline{\text{VC C}}$ den pan furisizzan

For North Germanic, we can illustrate two versions. In one, as typically in West Germanic, the 'extra' C comes from the onset of the initial of a following word:

(22) (a) Snorra Edda (Gordon 1957:17ff; his numbering)

475. $\overline{\text{VCC}}$ VCC $\overline{\text{VC C}}$
 ymr it aldna tré en jǫtunn losnar

485. $\overline{\text{VC CVVC}}$
 of lǫg lýðir en Loki¹⁸⁾ styrir

499. $\overline{\text{VC C}}$ VCC VCC
 hjqr til hjarta; þa es hefnt fǫður

(b) Old Swedish: Aldre Västgöotalagen (Noreen 1904:7)

16. $\overline{\text{VVC}}$ $\overline{\text{VC C}}$
 þær dīþi ok drak miolk

27. $\overline{\text{VVC}}$ $\overline{\text{VC C}}$
 þa stall lysæ, sum lagh sighia

(OSw gh = [ʃ]).

The same thing can occur across word-internal (morpheme, thematic) boundaries as well, where a cluster arises between syllables that would be an illegal final in the word. I take the minimal definition of 'syllable-final' to be 'word-final', since this is the one place where syllable boundaries are unambiguously decidable, as they must coincide with word boundaries. In the examples below I indicate the internal boundaries by hyphens:¹⁹⁾

(23) a. Eiríksmal (Fagrskinna): (Gordon 1957:148f):

1. $\overline{\text{VC C}}$ VVC $\overline{\text{VC C}}$ $\overline{\text{VC C}}$
 Hvat's þat drauma? Hug-ð-umk fyr dag rísa

b. Snorra Edda (see (22)):

478. $\overline{\text{VC C}}$ styn-j-a dvergar VVC fyr steindurum
411. VCC $\overline{\text{VC C}}$ VCC
mun systrungar sif-j-um spilla

The examples suggest that either across word, morpheme, or 'empty' formative boundaries, the coda of a light syllable can be optionally 'augmented' by the initial consonant of the onset of a following syllable, producing a 'derived' heavy syllable; regardless of whether the resulting cluster is canonical. Let us call this *boundary shift*:

- (24) Boundary Shift: Given two light syllables $\check{\sigma}_1$, $\check{\sigma}_2$, assign the first C of the onset of $\check{\sigma}_2$ to the coda of $\check{\sigma}_1$, so that $\check{\sigma}_1 \rightarrow \bar{\sigma}_1$.

To take one of the Old English examples (God sende, (18)):

- (25)
-
- $\check{\sigma}$ $\check{\sigma}$ $\bar{\sigma}$ $\check{\sigma}$
O R O R O R O R
| / \ | / \ | / \ | / \
C P Co C V C C V C C V C C V C C V C
| | | | | | | | | | | | | | | | | |
C V C C V C C V C C V C C V C C V C
g o d s e n d g o d s e n d

The result is a 'shared' C --- even though the CC sequence is phonotactically anomalous.

The possibility of a C being shared by two syllables --- which for phonotactically well-formed clusters is not problematical (see §4) opens the way to a simple account of another apparently odd type of heavy 'syllable'.

4 Resolved light syllables

Boundary shift is not part of the traditional conceptual armory or meta-language for talking about Germanic verse, though it is quite widespread and reasonably common.²⁰⁾ The subject of this section, however, has been long recognized, though never, I think, properly interpreted, and never tied in --- as I shall attempt to do --- with boundary shift and the phenomenon of quantity in general.

I am concerned here with *resolution*: two light syllables counting for metrical purposes (and we shall see for others) as one heavy. That is, in addition to the equivalence $VV(C) \equiv VCC$, we now have $VV(C) \equiv VCC \equiv VCV$. Since it is already clear (cf. §2) that heaviness is not a strictly linear notion (otherwise we would have $*VC \equiv VV$), but a hierarchical one, and since VV is a problem with respect to $VV \equiv VCV$ (why not $VC?$), it looks as if we will again need a configurational definition.²¹⁾

Though resolution is well recognized from Classical times onwards,²²⁾ it is worth illustrating from Germanic, which is our concern here. Here are examples from the major alliterative traditions, including one runic inscription in North-west Germanic, which I take to be a line of alliterative verse in the standard form (\widehat{VCV} = resolved disyllable):

- (26) a. North-west Germanic: Gallehus Horn (c. 400 A.D.; Anton-
sen 1975:41).²³⁾

\widehat{VCV} VCC VCC
 Ek Hlewagastiz Holtijaz horna tawido

- b. Old English (Beowulf):

21. \widehat{VCV} $\overline{VC} \ C$ \widehat{VCV}
fromum feoh-giftum on fæder bearme

22. \widehat{VCV} $_ \ VVC$ $_ \ VVC$
fela-hrör fēran on fēran wære

41. $_ \ VVC$ \widehat{VCV} $\overline{VC} \ C$
mādma mænigo þa him mid scoldon

--- under certain morphological conditions --- a VVC or VCC syllable can stand alone. But a VC syllable gets an affixal vowel. Conversely, a vowel in the stem syncopates after VVC or VCC, so that (potential) *VVCV, *VCCV sequences do not arise. (Historically speaking, we are dealing with deletion of vowels after heavy syllables; but synchronically, however we interpret the distribution, whether as a simple static equivalence or in terms of a 'derivation' with either epenthesis or deletion, the three syllable types constitute a natural class).

How does the resolution equivalence fit into the account of syllable structure I have been proposing? We can approach this through the general problem of how to syllabify VCV sequences. There are many proposals in the literature (see Anderson & Jones 1974, Árnason 1980:ch. 2), of two major types: one (exemplified by Hooper 1972) involves a 'universal' definition of the proper places to insert syllable boundaries according to the segmental makeup of the consonants involved; another, exemplified in the discussion in (Pulgram 1970), involves principles like either maximizing CV ('final minimalistic' syllabification), or maximizing VC ('final maximalistic'). But in perhaps the majority of cases, the arguments for VCV sequences do not yield determinate syllabifications based on any non-arbitrary principles.

In English, for example, a word like habit does not yield a uniquely defensible syllabification. On phonotactic grounds, one might want to divide $[_1hæb]_1 [_2t]_2$, since *[hæ] is not a well-formed English syllable (no branching anywhere in R); on the other hand, there are no phonetic properties of the medial [b] that mark it as having either syllable initial or final properties. (Unlike say the medial segment in city in a dialect that has $[sɪʔtɪ]$: here the [ʔ] is a marker of syllable finals, so that we have an unambiguous syllabification $[_1sɪʔt]_1 [_2ɪ]_2$.)

The best way to handle such ambiguous segments is clearly to take them as amphisyllabic, as *interludes* (Hockett 1955, Anderson & Jones 1974) belonging to both syllables. Thus the syllabification for habit should be:

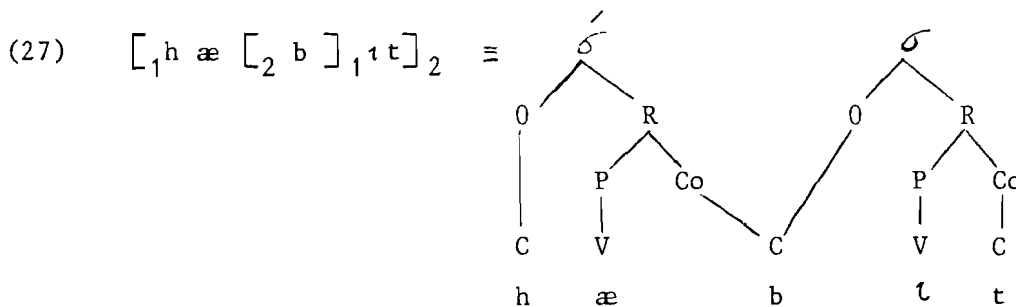

As it stands, (27) doesn't get us any closer to an account of resolution; but with a bit of adjustment it will. The adjustment is something like a play on words embodied in a notation: but since notations like these are geometrical metaphors for bits of unobservable but inferred structure, there is no harm in such an essentially 'hocus-pocus' procedure.

What do we mean by saying that a segment is amphisyllabic, or 'belongs to' two syllables? One interpretation is that it 'belongs' (strictly) to neither; another, stemming from the notations in (27), is that it 'belongs to' both simultaneously and literally. That is, there is a sense in which the two representations in (28) below are equivalent:

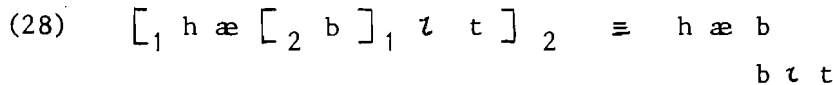

Given this, let us say that if a segment 'belongs to' two syllables σ_1 , σ_2 , then σ_2 'has' that segment, and so does σ_1 , i.e. the representation of habit is:

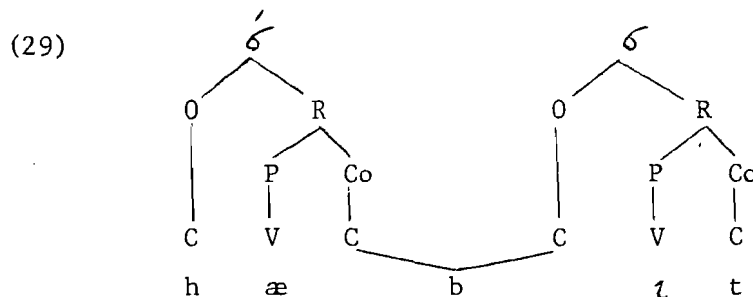

We code the notion of 'overlap' into the tree structure; and in doing so produce a tier at which --- if it is taken as input to rules of versification --- a VCV sequence counts as heavy because it *is* heavy.

One objection comes to mind immediately: how do we distinguish a 'pseudo-geminate' of the kind that results from this procedure from a real (phonetic) geminate? The answer arises from this consideration: a phonetic geminate *always* makes the syllable heavy; a medial C *may* make the syllable heavy. Thus geminates, like (many) other clusters, produce VCC configurations. So we can suggest that --- for Old English and Germanic in general --- a geminate is always part of the coda of the first syllable, and is not an interlude, whereas a single C belongs to both syllables. We would then distinguish OE ofer 'over' and Offa as:

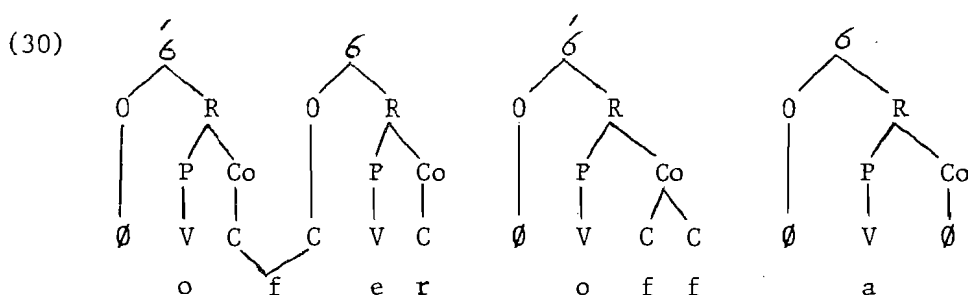

A potential parsing rule for syllables would then be:

- (31) Within the word, a sequence $[_{Co} C_1]_{Co} [_{O} C_2]_O$, where $C_1 = C_2$, is interpreted phonetically as C; whereas $[_{Co} CC]_{Co}$ is interpreted phonetically as CC.

This suggests that we add another tier of representation, giving a representation for ofer like:

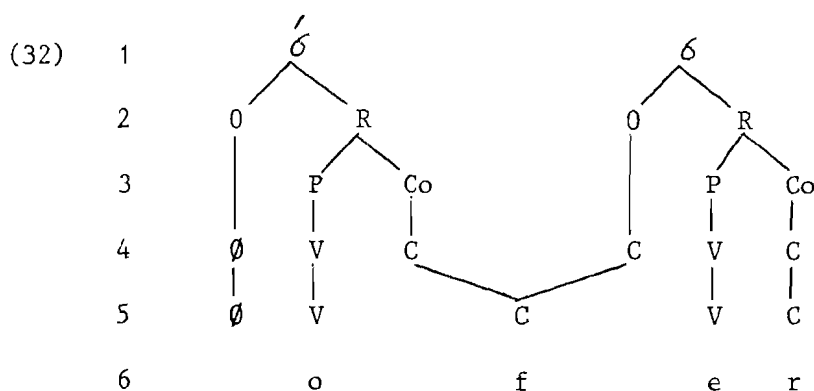

The parsing rule (31) operates essentially between tiers 4 and 5. We will see in §5 that there is more evidence suggesting this kind of structure. Let us call tier 4 'moric' and tier 5 'tactic'. (Tier 6 is 'phonological', and input to allophonic rules, etc.: thus the voicing rule producing [over] < /ofer/ operates here.)

5 Tier 4 and the long/short diphthong problem

One of the perennial difficulties in Old English phonology (at least for the past forty years or so) has been the apparent contrast between two sets of diphthongs; or between two sets of digraph spellings whose etymologies and subsequent histories, as well as metrical behaviour, suggest that they represent contrasting entities (to be careful). These are traditionally called 'long' and 'short' diphthongs. The 'long' ones, usually represented as ēa, ēo, īe are from original Germanic diphthongs or their i-umlauts: bēam 'tree' < */baum-/, flēogan 'fly' < */fliuγan-/, hīeran 'hear' < */xausján-/. Or from 'breaking' of long monophthongs: nēah 'near' < */næ:x-/, wēoh 'temple' < */wi:x-/. The 'short' ones, usually represented as ea, eo, ie derive from 'breaking' or velar umlaut of short vowels: seah 'he saw' < */sæx/, ealu 'ale' < */ælu/, heorte 'heart' < */xert-/, weorod 'troop' < */werud-/.

The distinction between the two sets (which is not made in the MSS) is clear on a number of grounds other than etymology. A first indication is subsequent history: the 'long' ēa, ēo develop along with the categories represented as æ, e, i.e. /æ:/, /e:/. Unless subject to shortening (in determinate environments) they come down in modern English with the expected /i:/ via the Great Vowel Shift; the 'short' ones come down with expected short vowel reflexes, even if --- because of the environments in which they occur --- they are often subject to later lengthening. (E.g. NE /ɑ:/ in heart is expected ME /e/ lowered before /rC/ and then lengthened; /ɛ:/ in ale is the expected result of ME open-syllable lengthening of /a/, etc.).

A second indication is behaviour in stems with variable affixation: the 'short' ones show the same affixation pattern as light stems with single segment graphs representing short vowels, e.g. neuter a-stem plurals

geoc-u 'yokes', geat-u 'gates', gebeod-u 'prayers'; wō-stem nom sg bead-u 'battle', sion-u 'sinew' vs. heavy mād 'meadow', læs 'pasture'. A third indication is the fact that 'long' diphthongs with no following C or only one are permissible alliterative lifts: gēar, fēa-, lēof (cf. (17) lines 1, 6 and 31), pēod (cf. (18) line 2), frēan (cf. (26) line 22). Whereas forms with 'short' diphthongs appear to require two following Cs: geong, geard- (cf. (18) line 13). Except, that is, if they are in the first syllables of disyllabic forms, in which case they appear as resolved lifts: e.g. in Beowulf we find

- (33)
- | | | | | |
|-----|----------------|---------------|----------------------------|-----------------------|
| | VCV | VVCC | VCV | |
| 5. | <u>monegum</u> | <u>mægþum</u> | <u>meodo</u> -setla ofteah | |
| | | VCV | VCC | |
| 12. | Dæm | <u>eafera</u> | <u>æfter</u> | cenned |
| | | VCV | VVC | |
| 60. | in | <u>woruld</u> | <u>wocun</u> | <u>weoroda</u> ræswan |

The problem has been how to interpret the contrast. The earlier handbooks simply divide the two into 'long' and 'short', with little if any comment on the nature of the distinction; the traditional ēa, etc. at least imply that length is on the first element, judging from writings like these and not e.g. ēā, and from the editorial treatment of forms where in a geo- spelling the e represents a palatalization diacritic and the vowel is long: geōmor 'sad' vs. gēac 'cuckoo'. More recent accounts that use phonetic or phonological transcriptions are divided; some place the length mark on the first element (/ǣa/ etc. in Pilch 1970), others on the second ([ǣɑ] in Kuhn 1961). But there is no discussion to speak of, and it is not clear what these transcriptions actually mean.

The intense scholarly debate, however, has not centred on the question of where the length is, but on whether there is actually any contrast at all, in the traditional sense. The trouble began with a paper by Marjorie Daunt (1939) in which she claimed that the 'short' ea, eo represented not diphthongs, but monophthongs (short), plus a diacritic indicating a secondary articulation of the following consonant (after the Irish model of indicating palatality and velarity by i, o diacritics). The issue was taken up again by Stockwell & Barritt (1951), Hockett

(1959) and others, and the debate was polarised according to interpretation of the 'short' digraphs. Stockwell & Barritt, and Hockett (though with different interpretations in detail) maintained that only the 'long' ēa, ēo were genuinely diphthongal, and that ea, eo represented neither diphthongs nor vowel + consonantal diacritic --- but rather retracted allophones of /æ/, /e/. One major argument of Stockwell & Barritt was based on 'universals' (though not, at that time, called by that name): that there were no attested languages with a short/long diphthong contrast, and therefore ēa vs. ea had to represent something else.²⁵⁾ As we will see below, while (by and large) this argument holds at the phonemic level, it does not hold phonetically; and the (surface) existence of both types is all that is really necessary to salvage the argument for a quantitative contrast in diphthongs.²⁶⁾

In Lass & Anderson (1975:ch. III) we took up the debate again, in the framework of a fairly abstract kind of generative phonology, and argued that the two types were in fact phonetically identical (both diphthongal), and differed only in their underlying representations, which were (of course) virtually the same as the historical inputs. We assumed a strict monomoric/bimoric opposition for all vocalic nuclei, and made no provision for any other possibility. The one point that can now be salvaged, I think, from that account is the re-establishment of the traditional position that both sets of nuclei were diphthongal, though the different-underlier/same-surface-form analysis is too closely tied to the mechanics of a derivational phonology to be accepted anymore: it is simply an artefact of a technique of analysis that allows synchrony to ape history, with no price to pay in terms of empirical responsibility. (Whether what I propose below falls into the same category is open for debate.)

In the light of the preceding discussion, however, I think it is now possible to allow for both types of diphthongs within the proposed model of syllable structure, and to fit them in in a quite natural way. A good place to begin is with long and short diphthongs in modern languages that have --- at least phonetically --- an unambiguous contrast of this type. Take a language which (a) clearly has phonemic diphthongs, and (b) a syllable structure like that of Swedish, where only heavy stressed rhymes are allowed, and both VVC, VCC types occur.

What would we predict would happen to diphthongs before CC --- assuming say that the CC were produced by a normal derivational process? Would the diphthongs monophthongize?

We can observe precisely this situation in Icelandic. Consider a case where the non-neuter form of an adjective is in -VVC, and VV is a diphthong; but in the neuter another C (/t/) is added, e.g. læs 'literate', neuter læst. What we get is traditionally transcribed as [ai:] vs. [ai] (e.g. Einarsson 1945). But phonetically this is inaccurate; the length is not, as far as I can hear, on the second element --- nor is it on the first. Both the long and the short nuclei are clearly diphthongs, and the distribution of vowel qualities over the temporal spread is roughly the same in both. Only the long one has the [a] and the [i] (actually more like [e]) qualities spread over a span appropriate to that of a long vowel, while the short one has the same qualities spread over a span appropriate to a short vowel. Diagrammatically:

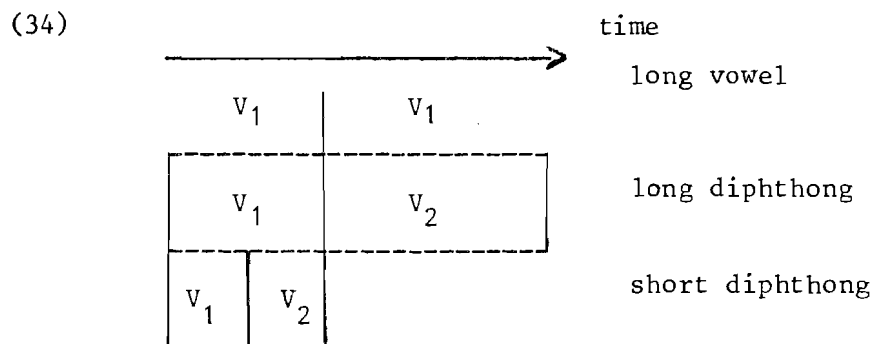

A short diphthong, that is, is *really* a short vowel, with two short components (half-morae). But whatever its internal structure, in terms of both real duration and syllable structure constraints, it is undoubtedly short.²⁷⁾

This suggests coping with the distinction in more or less the same way as we did with resolved light syllables. The purpose of tier 4 in (32) was to allow a 'surface' light syllable to be interpreted as heavy by splitting an interlude between two successive syllables. Here we can invoke the same procedure in reverse, by allowing a peak to be monomeric

at tier 4 and bimoric at tier 5 --- and having the quantitative rules of the language, like the metrical parsing for resolution, operate on that tier, disregarding 5. Thus the Icelandic forms cited above would be represented as:

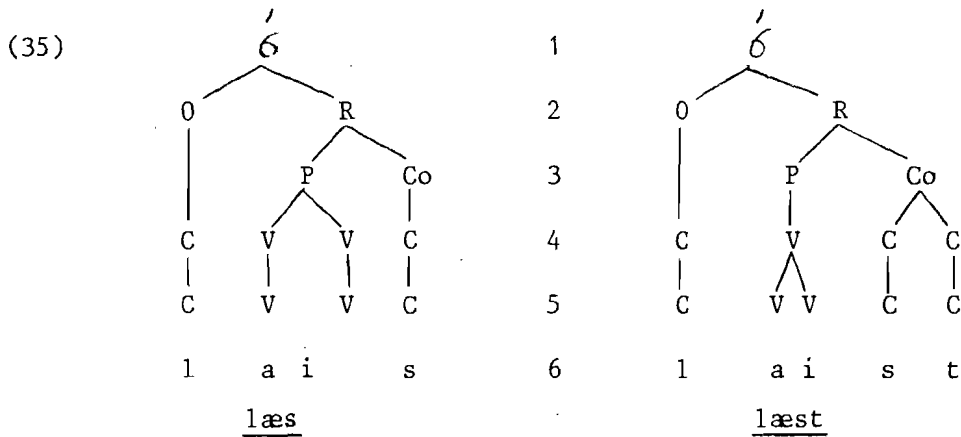

Tier 4 then is the fundamental moric tier, defining the content of a syllable with respect to (optional) rules of metrical choice, and obligatory rules for the distribution of quantities.

This suggests then that the mora sensu stricto is a higher-level quantitative or prosodic unit; and that given the definition of syllabic weight at tier 4, it is irrelevant whether a given mora at 5 is in fact 'mono-qualitative' or 'di-qualitative'. In other words, if we assume that tier 4 fixes quantity, the dominating node or nodes control the distribution of phonological material in the dominated segment(s). Thus a lexical /ai/ inserted under VV is allowed its full bimoric expansion, but /ai/ under V is forced to distribute itself within the bracketing limitations imposed by the single V. The image is that of lexical insertion under a category node; in this case, the number of nodes determines the number of morae.

This seems to provide a simple account of the undoubted existence of short and long di-qualitative vowel nuclei, and makes the two sets of Old English diphthongs non-problematical. A form like weorod is diphthongal (qualitatively) at tier 5, but short monophthongal (quantitatively) at 4; and we can assume that the CC configuration of the shared interlude also operates at 4, so that it can provide the conditions for a resolved light syllable. Thus a full resolved representation of weorod would be:

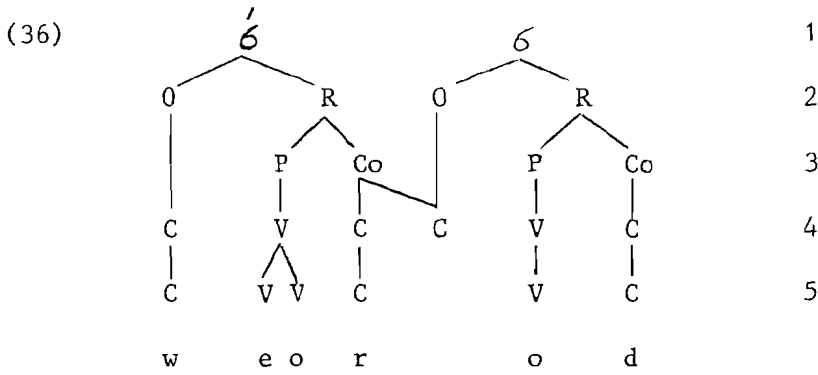

In conclusion: positing of an extra tier of moric representation, independent of but connected by rule to the phonological (segmental) representation, allows for a reasonably economical statement of (a) boundary shift, (b) resolution, and (c) the possibility of a long/short diphthong contrast. And most importantly, it takes all phenomena associated with legal alliterating lifts in Old Germanic verse, and groups them under a single quantitative primitive: mora counting. The only real 'abstraction' in this account involves the extra level of structure, and a separation of phonological quantity from the level of phonetic exponence.

NOTES

1. Early versions of this paper were given orally at seminars in Salzburg, Edinburgh, Dublin, Helsinki and Stellenbosch. I am indebted to various people who commented on the earlier versions, especially Gaberell Drachman, Kiki Drachman, Charles Kisseberth, Heinz Giegerich, and Cynthia Shuken. None of them swallows all of this.
2. Simpler than the 'sonority hierarchy' kind of template (Kiparsky 1979), though of course more complex than any linear model.
3. I avoid S,W labels for intrasyllabic nodes (as in Kiparsky 1979), for a number of reasons. Mainly: (a) the idea of using the same labels for 'sonority' types and degrees of prominence in accentual trees, as in the 'metrical' tradition generally, seems to me not to be a generalization, but a conflation of unrelated notions, with little justification apart from standard reductionist argument. (b) because I reject any notions based essentially on considerations of 'markedness' and the like (Lass 1975, 1980:ch. 2). I further restrict all morae of a syllabic to P, and do not allow for second morae of long segments to be assigned to Co (as in McCarthy 1979); while his arguments hold for the languages he discusses, they do not, as we will see, work for Germanic. In any case, the model I am proposing is based on IE languages, particularly Germanic, and I do not claim 'universality', nor would I want to.

A final reason for rejecting structures as complex as Kiparsky's (even though I will be producing some fairly complex ones) is a matter of 'overgeneration': I see no justification for 'stacking' of objects (like Ss and Ws) that have no direct correlates.

E.g. I take it as a procedural guide that no node that does not directly figure in the statement of a process or description of a state needs to occur in a representation.

4. For more arguments for length as moric, see Lass & Anderson 1975: ch. 1; Lass 1976:ch. 1.

5. If the nouns were regarded as having underlying forms like /wætr/, /tungl/, then (c, d) would be stated in terms of epenthesis rather than deletion. In either case the generalization with respect to trisyllabicity of derived forms and the nature of the first syllable would be the same.
6. Cf. the discussion of length vs. quantity in Allen 1965:ch. 6; 1973:ch. 4 ; Árnason 1980: ch. 2 .
7. At this point one might think of McCarthy's proposal (1979) that second morae of long vowels can be assigned to Co, not P; this has the advantage of allowing quantity to be defined not as branching of *either* P or Co, but as branching of Co only. But as we will see below, syllables of type (8) have a special status, which forces us to differentiate branchings of the two constituents.
8. Cf. the 'strong'/'weak' cluster distinction in Chomsky & Halle 1968:29 , and the discussion in Allen 1973:50ff. .
9. There are dialectal exceptions, due to incomplete implementation of the historical changes that led to the distribution in (11). For discussion and literature cf. Árnason 1980:§3.3. There are similar problems in Norwegian as well (Árnason; §3.2).
10. There are certain exceptions to this latter constraint, involving morphologically complex forms; see the discussion in Clark 1980 . On Swedish quantity in general cf. Eliasson 1978; Eliasson & La Pelle 1973 ; and Clark: ch. 3.
11. Examples from Árnason 1980:107 .
12. Actually the first stage, generalized throughout North-west Germanic, was the banning of the light -V# structures; it is not clear whether or not this was operative in Gothic (cf. Lass 1981:536, 542, n. 12).
13. For the historical and dialectal features of Swedish length neutralization, see the brief discussion in Bergman 1973:45ff. and

- Árnason; §3.3 . For historical details of the major quantitative adjustments cf. Wessén 1969:§§78-80, 174.
14. For an introduction to Old Germanic verse cf. Lehmann 1956. Syllabic structure and rhythm are discussed in ch. 3.
 15. From this point of view, the quantitative structure of Latin seems more like that of modern West Germanic than old West Germanic or modern North Germanic. -VC was an acceptable accented rhyme, and there were no accented -V rhymes. On apparent heavy -VC in Germanic see below.
 16. While this holds for Old English, as far as I can tell, it may not (exclusively) for Old Saxon: git it, huuan er (Heliand 134, 105) are both alliterating lifts. But there is probably an alternative explanation for these: they come under the heading to be discussed in §4.
 17. On this kind of disyllabic lift cf. §4 below.
 18. Another disyllabic lift cf. §4.
 19. The -j- in the last two examples do not represent morphemes in the strict sense, but thematic segments: in stynja 'groan' the formative of a class I weak verb; in sifja 'affinity' (pl) the formative of a ja-stem noun. The -x- in hugðumk is the weak preterite marker.
 20. In the first 100 lines of Bēowulf, 20 out of 256 lifts are boundary-shifted, i.e. just a shade under 10%. Other samples of OE verse show from 5% (Cotton Gnostic Verses) to 10% (Old Northumbrian fragments).
 21. In principle a phonetic definition might be possible, if one follows the 'arrest' theory in (Allen 1973); but I have my doubts whether what is going on here is strictly phonetic in any physical sense. Resolution can also be 'explained' temporally, as in J.C.

Pope's 'musical' theory of OE scansion. But it seems naive to attempt to define quantitative (as opposed to durational) properties in terms of real time, and to assume that poetry must have a 'beat' like music. In any case, a uniform account, with no extra primitives, seems to be worth aiming at, and there is no need for time or low-level phonetics in the rest of the account.

22. See Allen 1965:ch. 6 for discussion; it appears in Latin verse at least as early as Ennius.
23. Following Antonsen, I use z for the rune Υ , usually transliterated R. See his arguments (1976:§1.2), and the discussion in (Teleman 1980).
24. Due to the state of the MS, there are a number of defective lines in which it is impossible to determine which lifts alliterate.
25. For a reasonably detailed account of the debate, see Lass & Anderson 1975:ch. III. Most of the major references are given there.
26. Actually a phonemic length contrast in diphthongs is attested in North Welsh (Thomas 1966).
27. I am grateful to Kristján Árnason for producing endless diphthongs for me one tedious day in Edinburgh. For an interesting corroboration see the spectrograms of læs, læst in Árnason 1977:372. Árnason's comment (371, n. 6) is that 'the short variant looks like a miniature of the long one'.

REFERENCES

- Allen, W.S.
 1965 Vox Latina. Cambridge: Cambridge University Press.
 1973 Accent and rythm. Cambridge: Cambridge University Press.
- Anderson, J.M. & Jones, C.
 1974 Three theses concerning phonological representation.
Journal of Linguistics 10.1-16.
- Antonsen, E.A.
 1975 A concise grammar of the older runic inscriptions.
 Tübingen: Niemeyer.
- Árnason, K.
 1977 Quantity in Icelandic: a historical and comparative study.
 University of Edinburgh Ph.D. Thesis.
 1980 Quantity in historical phonology. Icelandic and related cases. Cambridge: Cambridge University Press.
- Bergman, G.
 1973 A short history of the Swedish language. Lund: Berlingska
 Bocktryckeriet.
- Chomsky, N. & Halle, M.
 1968 The sound pattern of English. New York: Harper.
- Clark, G.
 1980 The phonology of the Swedish word accents. Cambridge Uni-
 versity Ph.D. Thesis.
- Daunt, M.
 1939 Old English sound changes reconsidered in relation to
 scribal tradition and practice. Transactions of the Philo-
 logical Society 108-37.

- Einarsson, S.
 1945 Icelandic: grammar, texts, glossary. Baltimore: John Hopkins Press.
- Eliasson, S.
 1978 Swedish quantity revisited. In E. Gårding, G. Bruce, R. Bannert (eds.) Nordic Prosody. Lund: Gleerup.
- Eliasson, S. & LaPelle, N.
 1973 Generativa regler för svenskans kvantitet. Arkiv för Nordisk Filologi 88.133-46.
- Gordon, E.V.
 1957 An introduction to Old Norse. Rev. A.R. Taylor. Oxford: Clarendon Press.
- Hale, W.G. & Buck, C.D.
 1903 A Latin grammar. Repr. 1966. University, Alabama: University of Alabama Press.
- Hockett, C.F.
 1955 Manual of phonology. Baltimore: Waverley Press.
 1959 The stressed syllabics of Old English. Language 35.575-97.
- Hooper, J.B.
 1972 The syllable in phonological theory. Language 48.525-40.
 1976 An introduction to natural generative phonology. New York: Academic Press.
- Hulbert, J.R.
 1935 Bright's Anglo-Saxon Reader, Revised and enlarged. New York: Holt.
- Kiparsky, P.
 1979 Metrical structure assignment is cyclic. Linguistic Inquiry 10.421-42.

- Klaeber, Fr.
1950 Beowulf and the Fight at Finnsburg.³ Boston: Heath.
- Kohler, K.
1966 Is the syllable a phonological universal? Journal of Linguistics 2.207-8.
- Kuhn, S.M.
1961 The syllabic phonemes of Old English. Language 37.522-38.
- Lass, R.
1975 How intrinsic is content? Markedness, sound change and 'family universals'. In D. Goyvaerts & G.K. Pullum (eds.), Essays on the Sound Pattern of English. Ghent: E. Story-Scientia.
1976 English phonology and phonological theory. Synchronic and diachronic studies. Cambridge: Cambridge University Press.
1980 On explaining language change. Cambridge: Cambridge University Press.
1981 Undigested history and synchronic 'structure'. In D. Goyvaerts (ed.), Phonology in the 1980's. Ghent: E. Story-Scientia.
- Lass, R. & Anderson, J.M.
1975 Old English phonology. Cambridge: Cambridge University Press.
- Lehmann, W.P.
1956 The development of Germanic verse form. Austin: University of Texas Press.
- McCarthy, J.J.
1979 On stress and syllabification. Linguistic Inquiry 10.443-65.
- Markey, T.L.
1976 A North Sea Germanic reader. München: Fink.

- Naumann, H. & Betz, W.
1967 Althochdeutsches Elementarbuch.⁴ Berlin: De Gruyter.
- Noreen, A.
1904 Altschwedisches Lesebuch.² Stockholm: Aktiebolaget Ljus.
- Pilch, H.
1970 Altenglische Grammatik. München: Hueber.
- Pope, J.C.
1966 The rhythm of Beowulf.² New Haven: Yale University Press.
- Pulgram, E.
1970 Syllable, word, nexus, cursus. The Hague: Mouton.
- Stockwell, R.P. & Barritt, C.W.
1951 Some Old English graphemic-phonemic correspondences: æ,
ea, e. Studies in Linguistics, Occasional Papers, 4.
- Sweet, H.
1967 Sweet's Anglo-Saxon reader. Rev. D. Whitelock. Oxford:
Clarendon Press.
- Teleman, U.
1980 Occam's Razor and the rise and fall of a Germanic phoneme.
In Alvar. A linguistically varied assortment of readings.
Studies presented to Alvar Ellegård on the occasion of his
60th birthday. (Stockholm Papers in English Language and
Literature, 1).
- Thomas, A.R.
1966 Systems in Welsh phonology. Studia Celtica 1. 93-127.
- Wessén, E.
1969 Svensk Språkhistoria. I. Ljudlära och ordböjningslära.¹⁸
Stockholm: Almqvist & Wiksell.