

Changing perceptions of teachers regarding the importance and competence of their principals as leaders

Bernardus Grobler

Department of Education Leadership and Management, University of Johannesburg
bennieg@uj.ac.za

Thomas Bisschoff

Department of Social Justice and Education, Birmingham University, UK

Amrat Beeka

Mpumalanga Department of Education

We examined the perceptions of teachers on the importance and competence of principals as leaders before and after an intervention programme on holistic leadership. The research was quantitative and contextualized in the Secunda region of Mpumalanga province in South Africa. The methodology followed a literature study and an empirical investigation in the form of a pre- and post-test experimental-type design. A structured questionnaire was administered to 400 teachers in 40 randomly selected schools divided into two groups. One group of 20 principals was provided with an intervention programme regarding the dimensions of holistic leadership. The other group of 20 principals was not exposed to the intervention programme. The perceptions of teachers from their schools were probed using a pre-post-test design. The intervention programme and biographic variables served as independent variables whilst the seven factors of holistic leadership formed the dependent variables. Principals who were exposed to the intervention programme were perceived by their teachers to be more competent than their counterparts who were not exposed to the programme.

Keywords: educational change; head teachers; leadership; school principals

Introduction

Education reforms in South Africa, as in other parts of the world, are accompanied by increased responsibilities and accountabilities for everyone working in schools, including the principals. The changing role of leaders within a reform environment has spawned much research, especially around principalship. An increasingly important sub-theme in this research focuses on the desirability of the principalship as a career and, more precisely, the question of why there are so few aspirant principals in some countries (Gronn & Rawlings-Sanaei, 2003).

The research sought to probe an aspect of this lack of aspirant principals from the perspective of the teachers. If the perceptions of teachers regarding the importance and the competence of their principals can be positively changed it can indirectly address the shortage of aspirant principals.

The researchers probed the perceptions of teachers in Mpumalanga province as to the importance and present competence of their leaders regarding certain dimensions of holistic leadership (Grobler & Van der Merwe, 1996). A structured questionnaire containing items that operationalised the seven dimensions as defined by Grobler & Van der Merwe (1996) (professionally inviting culture; effective communication; ethical foundation; vision of excellence;

empowerment of followers; personal mastery and authentic collaboration) was used in a pre-test, followed by an intervention programme and the post-test.

Beeka (2009) identified numerous challenges faced by school principals in Mpumalanga province such as new forms of advocated leadership, HIV/AIDS awareness, poverty alleviation and the plight of rural and township schools. There also appears to be a dearth of espoused policies concerning the transformation of leadership from one of a bureaucratic nature to a more collaborative form of management. Leading the way in South Africa are the so-called "*Batho Pele Principles*" (people first) which have their roots in a series of policies and legislative frameworks. The principles are ideals from the South African Constitution (SA, 1996) and Public Service and Administration website for the Department: Public Service and Administration: consultation; setting service standards; increasing access; ensuring courtesy; providing information; openness and transparency; redress and value for money. The legislative framework is provided by Section 32 of the Constitution of South Africa (SA, 1996), the White Paper on the Transformation of the Public Service of 1997, the Public Service Regulations of 1999 and 2001 and the Administrative Justice Act of 2000. These legislative frameworks seek to transform a culture of Public Service delivery from prescribing service packages to citizens, to putting citizens at the centre of service delivery. Accordingly, all government departments both national and provincial are compelled to align their service delivery mandates and service delivery improvement plans with the overall service delivery priorities of the government based on the needs of the citizens. They call for the setting up of service standards, defining outputs and targets, and benchmarking performance indicators against international standards.

Educators are also public servants in the South African context and all Education Departments in South Africa have issued circulars to public schools informing them about the implementation of the *Batho Pele* principles. Principals as leaders of their schools are therefore supposed to transform their "old and redundant" leadership forms, discard them and adopt more collaborative forms of leadership. It is a relatively simple matter to "espouse the ideal" of collaboration in the form of mandates far removed from the reality of the school situation. The question still remains "how does one implement collaborative forms of leadership in a bureaucratic system" characterized by mandates? Furthermore no forms of collaboration have been modelled and little to no training has been provided to school principals to assist them in order to "deliver service to their clients". The literature provides no answer to "mandated collaboration" and although leadership models do address certain aspects of collaboration there is no empirical model in South Africa that can serve as a guide to school principals regarding collaborative forms of leadership that considers the various contextual issues present. Political realities and social issues, among many other things, all influence leadership in some way or other and it seems as if a holistic approach to leadership could assist in alleviating some of the above realities. Thus, one of the problems that a school principal in South Africa faces is the gap that exists between the ideal or espoused forms of leadership and that which is practised in the system.

Statement of the problem and purpose of the study

The purpose of the study is to examine the perceptions of teachers on the importance of specific aspects of holistic leadership and the competence of principals as leaders, before and after an intervention programme on holistic leadership. This paper does not describe the design and development of the intervention programme as such as these details are available in the study of Beeka (2009:125-142). However, the main aspects pertinent to adult learning were

built into the intervention programme (Paauwe & Williams, 2001). The research is quantitative in nature and is contextualized in the Secunda region of Mpumalanga province, South Africa.

The overriding research question is thus two-fold:

- What are the perceptions of teachers on the importance of the seven aspects of leadership?
- What are the perceptions of teachers on the competence of their principals on each of the seven aspects before and after an intervention programme on holistic leadership?

Relevant literature on educational leadership

It appears that educational leadership is a confusing concept that seems to be characterised by a multitude of theories and models. Furthermore, the educational leader has a multitude of goals that he or she has to strive towards with the primary goal being that of “teaching and learning”. Thus, while many of the dimensions of leadership are generic to leadership in general, the educational leader is also concerned with an ideological dimension as well as formal prescriptions and other norms that attempt to regulate social behaviour.

Although the literature on leadership abounds with possible leadership constructs, there are not many that attempt to guide the educational leader through the quagmire of how to lead teachers and learners amidst the many complexities present in a bureaucratically mandated education system. Furthermore, theories from organisational leadership seem to apply to most of what educational leaders are supposed to do and there seem to be many dimensions of leadership that overlap with one another without being exclusive. It is amidst the context of “these muddy waters” (Phillips, 2006) that we attempt to clarify the role of the school leadership.

A brief survey of the literature indicates that the earliest leadership studies focused on physical, sociological and psychological traits of the leader (Litterer, 1993; Sikula, 1993; Modiba, 1997). The personal-behavioural approaches in turn suggested that leaders should consider situational variables such as the expectations, skills and previous experience of their followers (Hersey & Blanchard, 1989; Beare, 2001; MacBeath, 2007). If leaders were not able to change these variables then they should change their leadership styles. The contingency theory, on the other hand, attempts to explain the importance of leader-member relationships, structure of the task at hand and the use of positional power (Nxumalo, 2001).

More recent approaches to the explanation of leadership tend to concentrate more on the skills and knowledge needed to involve followers in decision-making. Then again numerous models and theories such as instructional leadership (McEwen, 2003), charismatic leadership (Pounder & Coleman, 2002), transactional leadership and transformational leadership (Burns, 1978; Sergiovanni, 1990; Pounder & Coleman, 2002; Clarke, 2007) have emerged from research into leadership. They all contribute to school leadership in some or other unique way.

Fullan (2005), in turn, believes that the answer to school effectiveness lies in what he terms ‘sustainable leadership’. He espouses eight elements of leadership that act in a three-tier contextual fashion: Public service with a moral purpose, a commitment to changing contexts, lateral capacity-building through networks, intelligent accountability and vertical relationships, deep learning, dual commitment to short- and long-term results, cyclical re-energizing and the long-arm of leadership (Fullan, 2005). Caldwell (2006), in contrast, acknowledges the suggestion of leadership that is sustainable but makes out a case for re-imagining educational leadership as the present leadership theories and models have failed to meet the expectations that the stakeholders have of them. Brauckmann and Pashiardis (2011) advocate the use of various leadership styles within a holistic leadership framework and conclude that leadership is a complex mixture of the five styles they explored. They contend furthermore that the

various sets of leadership perceptions, behaviours and practices influence the main purpose of a school's mission which is enhancing student learning. Moller (2005:47) also postulates that leadership must go beyond dedication, skills and leadership styles by promoting a moral enterprise which develops people by fostering the acceptance of group goals that can be translated into improved learner performance underpinned by moral imperatives. The presence of a firm ethical foundation (Northhouse, 2004) thus seems to be a moral imperative for school leaders as each of the other dimensions is directly or indirectly influenced by this ethical foundation (see Figure 1).

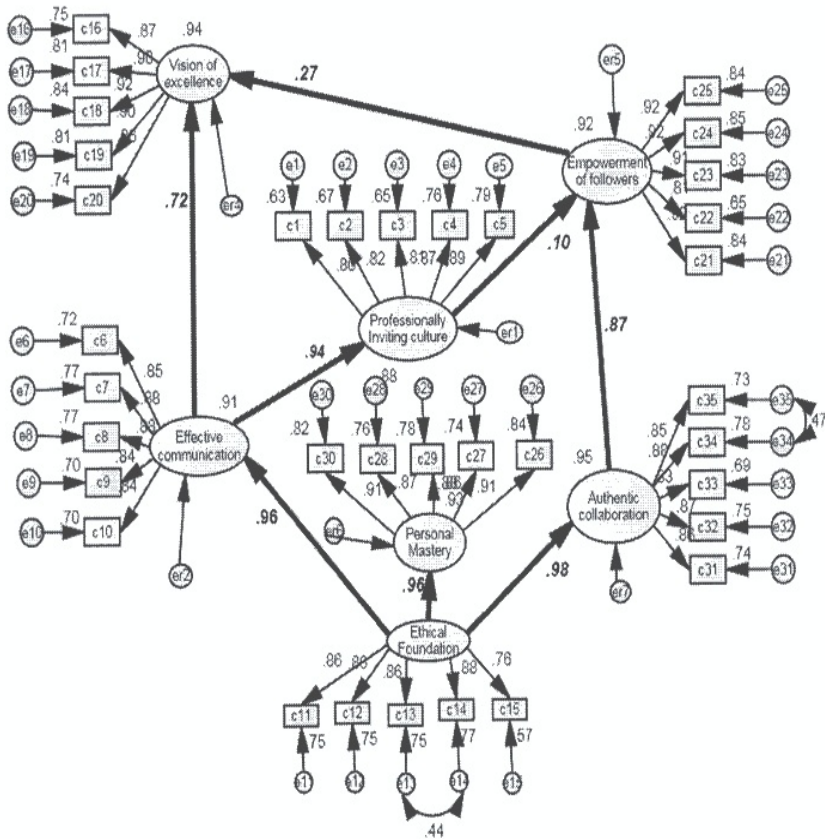

Figure 1 Causal pathways of Model 1 as postulated by Grobler & Van der Merwe (1996) as represented by AMOS 15.0 (Beeka, 2009)

CMIN/DF = 2.87; $p < 0.01$; CFI = 0.95; NFI = 0.92; RMSEA = 0.06; N = 350

It is with these aspects in mind that we attempted to change the perceptions of an important group of stakeholders, namely, those of educators, about the competence of school principals with respect to certain important dimensions regarding the holistic leadership of school principals.

What is clear from the above brief exposition of leadership is that the role of the school principal as a leader has become extremely complex. South African public schools are also part of a bureaucratic system where command and control strategies, resulting from the numerous mandates, are in conflict with the espoused collaborative approaches that are advocated. Furthermore, the various terms that characterize educational leadership theories and models such as elements, aspects, dimensions, strategies, characteristics, traits, components, key lessons, key factors, competencies and a host of other terms to describe leadership bring confusion to the debate about effective school leadership. The researchers believe that each model has some unique features but that parsimony is needed as many of the models and theories are advocating the same things but using different terms to describe them.

This research will investigate the possibility of a holistic approach to school leadership that is participatory, collegial and committed to the teacher, learner and school community (Dzvimbo, 1996). School principals should develop an approach to leadership which will create an open school climate and team-spirit as this could assist teachers in developing positive perceptions of school leadership. However, despite years of reform efforts, South Africa continues to lag behind when it comes to international comparisons and has failed to raise performance of historically disadvantaged learners (Taylor, Muller & Vinjevold, 2004; Soudien, 2007). According to Scheerens and Bosker (1997) and Sergiovanni (2005) research has identified a range of factors associated with effective leadership. These factors, however, need to be synthesized into a holistic model that could assist principals in moving away from the, antiquated bureaucratic and authoritarian leadership practices to a more democratic approach that has the possibility of enhancing positive perceptions among educators regarding school leadership. The existing hierarchy must somehow be incorporated and utilized to produce system improvements (Edwards & Lawler, 1994; Gilbert, 1993).

This particular research project investigates the holistic approach advocated by Grobler and Van Der Merwe (1996) and further explored by Beeka (2009). This approach was selected as the seven dimensions involved in the approach cover key variables considered important for a dynamic holistic leadership model and can be applied in differing contexts. A key variable was the perception of teachers as followers as it was believed that their perceptions would be more accurate than the self-perception of their leaders (Charlton, 1993). A wider study that may include the perceptions of people outside the school can be considered, but the present conversation worldwide is still about moving to 'shared professional leadership' with the emphasis on sharing amongst teachers rather than 'shared community leadership' with others outside the school. As persons outside the school do not have the knowledge or the exposure that teachers have regarding the leadership abilities of principals it was decided to elicit the perceptions of teachers. We consider this a strong and unique aspect of the research design.

Therefore, to summarize the above introductory comments, it seems that one of the main challenges to school principals is to use the various dimensions of leadership in a more holistic way. Another challenge is that the education system in South Africa is part of a bureaucratic structure that is not conducive to taking rapid decisions that are necessary when large scale change is introduced. This structure does not facilitate teamwork as power levels present in the hierarchical structure are not helpful for promoting the trust that is needed when shared decision-making is important. Hence a new leadership model, that will assist principals to

manage large change processes while still maintaining high teacher and learner productivity to facilitate school effectiveness, is needed. To this end, the holistic model of leadership will be further researched. It involves seven dimensions of leadership and could possibly provide a more holistic and dynamic view regarding school leadership. The seven dimensions were named:

- The creation of a professionally inviting culture;
- Effective communication;
- An ethical foundation;
- A vision of excellence;
- Empowerment of followers;
- Personal mastery;
- Authentic collaboration.

This research attempted to address the leadership development of school principals in that an intervention programme was given to a group of principals in an attempt to see whether the perceptions of their teachers could be changed regarding the dimensions of holistic leadership. It should, however, be kept in mind that the intervention will probably not resolve all the current challenges facing the school principal as leader.

Although the literature review put forward reports on what different writers regard as their contribution to the ongoing debate, an attempt is made to indicate a shift from a bureaucratic to a holistic model in local school governance. This is the reason why the study elicits the perceptions of teachers on the leadership behaviour of their principals and not the community's perceptions. Although discussion of the terms 'charismatic leadership', 'transactional leadership' and 'transformational leadership' do not always shed light on this 'bigger picture' distinction and trend in the two extremes, it clarifies the conversation that is taking place.

There are clear differences between the leadership required (in importance and competence) in the case of bureaucratic and holistic leadership. Bureaucratic leadership involves ensuring clear focus and communication, strong and accurate information systems so that each level in the organisation is aware of and adhering to the organisational objective. Holistic leadership requires negotiation of meaning; securing compromises; maintaining alliances and mutual tolerance and encouraging collaboration. All this as previous research (Grobler & Van der Merwe, 1996) has indicated, culminates in the seven aspects of holistic leadership, namely: the creation of a professionally inviting culture; effective communication; an ethical foundation; a vision of excellence; the empowerment of followers; personal mastery and authentic collaboration.

Ethical considerations

One of the main ethical considerations was that the researcher would respect the dignity of the people involved and would not expose them to intentions and motives not directly related to the research project. Respect for the autonomy of the participants required that the participants were treated as unique human persons within the context of his or her community system. Freedom of choice was safeguarded by only involving principals who agreed to participate. It is also important that the questions asked were valid and reliable. To this end the researchers first conducted a pilot survey in order to determine the clarity of the questionnaire items and whether they could validly and reliably discriminate between the participants on the variables under scrutiny (Heiman, 2001). The content validity was checked by handing the questionnaire to 20 school principals who were not part of the research and the reliability of their answers was determined using the Cronbach Alpha reliability measure. The wording in five of the items

was adjusted because of the feedback received from the principals. The confidentiality of the respondents was respected. The research findings and conclusions were made available to the respondents of all schools in the province. Furthermore a covering letter was included with the questionnaires, informing the respondents that their anonymity would be maintained and respected and the findings and conclusions would be stated in such a way that no school would be identified. Respondents were requested to provide honest responses so as to ensure the authenticity of the research. Finally, consent and approval by the Mpumalanga Department of Education were obtained.

The intervention programme

Leadership development is a complex process because individual adults learn in many different ways, consciously or unconsciously, in an unmanaged, self-managed or another-person-managed way (Baldwin & Patgett, 1994). The model of Beeka (2009) indicates that the seven factors in educational leadership function in a holistic way.

With respect to the model in Figure 1 the ethical foundation influences effective communication, personal mastery and authentic collaboration in a direct way, where direct refers to a single arrow with no intermediary dimension in between (Arbuckle, 2007). This indicates the importance of an ethical foundation as it involves elements of trust, mutual respect and doing that which you espouse to be doing. All these elements need to be present if effective communication is to occur. Further to this direct influence of an ethical foundation a professionally inviting culture is in turn influenced by effective communication (an intermediary) in an indirect way and authentic collaboration and a professionally inviting culture both also influence the empowerment of educators indirectly. Empowered educators and effective communication indirectly influence the achievement of a vision of excellence which includes the moral imperative of enhancing student learning. This indicates that the seven factors involved in educational leadership influence one another in a holistic way and one needs to consider this when designing an intervention model for school principals. In the light of the above finding the ethical foundation was used as a basis and multiple modes of presentation such as group work and self-reflection strategies were used in the intervention programme (Paauwe & Williams, 2001). During the intervention the 20 principals involved completed both sections of the questionnaire regarding the importance of and their perception of their present competence regarding holistic leadership before the intervention programme. The principals completed both sections of the questionnaire independently of one another regarding the importance and their perception of their present competence regarding holistic leadership. The principals were then divided into seven groups and each group was then given an opportunity to name one of the groups of questions belonging to a particular dimension. For example, every five questions were grouped according to the seven factors found by Grobler and Van Der Merwe (1996) and provided with a suitable name. In the original research, questions 11 to 15 were named an ethical foundation but the principals involved in the training suggested numerous alternative names. This gave rise to intensive debate and reflection on the part of the principals as to the importance of an ethical foundation with respect to leadership. Once the names for the seven factors had been considered, the 20 principals were asked to indicate possible causal links between the seven factors using only the latent factors as represented by the model in Figure 1. This was done because there are a large number of possible causal links and this allowed principals to consider, for example, whether one could communicate or collaborate effectively if one does not have a moral basis for doing so. The various alternative models suggested by the principals were then compared to the model of Beeka (2009) as this model

was confirmed (CFA) using structural equation modelling. The model as a whole displayed suitable fit indices (Arbuckle, 2007:586-592) with all pathways being statistically significant. To improve the fit of the model two error terms were allowed to co-vary. The various measures of fit used are provided in Figure 1. In the final stage, the principals completed the questionnaire again and then scored themselves with respect to the seven factors for both importance and competence to compare their pre-and post intervention scores.

The intervention programme and the biographic variables served as independent variables and the mean scores on the seven factors were dependent variables. *The hypothesis was that the intervention programme would cause a statistically significant change in the mean scores between the pre-and post-tests of the group of principals as perceived by their teachers with respect to their competence in these seven aspects of holistic leadership.*

Research design

In the research, the quantitative method of research was utilized. Creswell (2003) and McMillan and Schumacher (2004) maintain that quantitative research is concerned with establishing relationships and giving a possible explanation of the causes of changes in the perceptions of various groups involved. The researchers also used multivariate analysis of variance to probe possible relationships and differences between the various independent groups among the teachers but this is not reported in this article due to limitations of length. This research used a literature survey to elucidate and determine the essence of holistic leadership and guided by the model of Beeka (2009) designed a pre- and post-test intervention programme to determine whether a possible change in teachers' perceptions towards their principals' dimensions of leadership could be realized.

One can argue that a limitation of this study is the relatively short period between the training and the gathering of data from the teachers. It is however important to realise that the trend towards perceptions of enhanced leadership are clearly gleaned from the data and a follow-up project may be designed to establish to what extent the training enhances sustained leadership development in the behaviour of principals over a longer period.

Description of the sample

The schools in the province are spread over a wide geographic area and are divided into 10 districts. We selected three districts and 40 schools were randomly chosen from these districts. The principals had only limited occasion to receive training as their schools could not afford to have them away from school — the Department of Education had strict regulations regarding absence from school to receive training of any kind. Also, the more schools involved in the training the better. Because we wanted to obtain the perceptions of the teachers regarding the principals' leadership in an experimental design, we had to make use of the same respondents on two different occasions.

The wide geographic distribution of schools also complicated the sample and schools that were mostly classified as urban were involved as the training centre was situated in an urban area. Respondents from 22 secondary and 18 from primary schools were involved. The researchers went to each of the 40 selected schools personally and asked the principal's permission to involve each school. The researchers made use of the staff enrolment lists and selected 10 permanent teachers from each school and handed out questionnaires to complete after explaining the ethical considerations carefully. These questionnaires were personally collected by the researchers one week later from the respondents in a sealed envelope. The researchers used a code which only they knew to assist them to identify the same respondents

a second time. At the same time the 20 selected principals were invited to attend a training programme in one month's time and they formed the experimental group. Due to logistic, economic and other regulatory reasons, the intervention programme could only last one day. However, the researchers were able to have one more workshop with the 20 principals, two weeks after the initial training, where group discussions and reflection about leadership dimensions were interrogated. The researchers also took time to oversee the distribution of the questionnaires for the pre-tests. Four hundred (400) questionnaires were distributed in this manner. For the pre-test 360 were returned and could be used for analytical purposes. One hundred and ninety (190) were from the experimental group and 170 from the control group of schools. Therefore, the response rate was 90% and these data were submitted for analysis to the statistical consultancy (STATKON) of the University of Johannesburg. Approximately two months after the training programme had taken place the researchers again visited the schools and handed the same questionnaire to the same respondents to complete and place in a sealed envelope. This involved travelling and effort but the co-operation of the educators was excellent and a good return was assured. Of the 400 questionnaires, 350 had data that could be used, representing a return rate of 87.5%. The researchers then used only the 350 respondents who had completed both pre-and post-tests. Of the 350 respondents, 190 were from the schools whose principals had been trained while 160 were from the control group whose principals were not trained.

Both pre-test and post-test data were analysed using the SPSS 15.0 (Field, 2009) programme. Both sets of data were subjected to factor analytic procedures and in both pre- and post-tests the data reduction resulted in the same factors. Because both pre- and post-tests gave rise to the same factors, it was decided to use only the results of the post-test in describing the bio-and demographic characteristics of the sample.

Analysis of the biographical data from the questionnaire

The various biographic details are now briefly discussed.

The sample of 350 respondents consisted of 79 (22.6%) male and 271 (77.4%) female respondents. The ratio of male to female educators in Mpumalanga is about 1:3 (Department of Education, 2006) hence this sample (1:3.4) can be said to be representative of gender of teachers for Mpumalanga. Fifty-five (55) (15.7%) were deputy principals and 295 (84.3%) were educators. The ratio of management (deputy principals) to educators should be about 1:5 and hence this sample (1:5.4) also represents management to educators in Mpumalanga. The sample had 110 (31.4%) educators with less than 10 years teaching experience and 240 (68.6%) with 10 or more years teaching experience. The majority of the sample thus consisted of educators who could be classified as experienced teachers. Of the 350 respondents, 296 (84.6%) had male principals and 54 (15.4%) had female principals. Schools in Mpumalanga have never had sufficient female principals and this legacy of the past appears to have remained. Males are still over-represented with respect to gender of school principals. Of the 350 respondents, 279 (79.7%) perceived their learners as belonging to the average and below average and poor socio-economic groups and 71 (20.3%) perceived their learners as belonging to the above average socio-economic group. This is fairly representative of socio-economic status of learners in Mpumalanga. One hundred and eighty-seven (187) teachers (53.4%) were from secondary schools and 163 (46.6%) from primary schools. The sample was selected as 55% secondary schools and 45% primary schools and this is representative of the selected sample. The sample is, however, over-representative of secondary schools in Mpumalanga (DoE, 2006).

Further analysis of the data from the questionnaire: analysis of the pre- and post-test results

There was a vast amount of data and researchers had to select relevant data for analysis. In order to follow the analysis more clearly the original categories were collapsed and recoded. The original six-point scale was collapsed to a four-point scale with 1 being equal to 'not important at all' to 'relatively unimportant' and 'totally' to 'partially incompetent' and 4 as representing 'very important' and 'extremely competent'.

The items in the questionnaire for both pre-and post-tests were subjected to a factor analytic process and in both pre- and post-tests seven factors were obtained. The reliability coefficients obtained are summarized in Table 1.

Table 1 Reliability coefficients of the seven factors of holistic leadership on pre- and post-tests

Factor names	Cronbach's alpha (Section B - Importance)		Cronbach's alpha (Section C - Competence)	
	Pre-test	Post-test	Pre-test	Post-test
Professionally inviting culture	0.820	0.800	0.897	0.892
Effective communication	0.862	0.853	0.900	0.904
Ethical foundation	0.910	0.909	0.902	0.911
Vision of excellence	0.872	0.860	0.897	0.904
Empowerment of followers	0.911	0.879	0.912	0.915
Personal mastery	0.872	0.847	0.875	0.887
Authentic collaboration	0.902	0.897	0.940	0.934

As all reliability coefficients were above 0.7 and 74.05% of variance could be explained by these factors, it was decided that these seven factors could be used in the pre- and post-test analysis. If the hypothesis is correct then the *post-test group which followed the intervention programme should show a significant difference in their competence mean scores with respect to the dimensions of holistic leadership, as perceived by their teachers*. A simplified diagram of the process followed is provided in Figure 2.

The significant differences between the pre- and post-test groups on the seven factors are displayed in the factor mean scores in Table 2.

The data in Table 2 indicate *no statistically significant differences* between any of the seven factors between experimental and control groups on the pre-tests regarding their perceived importance. The respondents had the perception that the seven factors were important for school principals. However, on the post-tests there was a statistically significant difference *between the teachers' perceptions of the competence of their principals in the experimental*

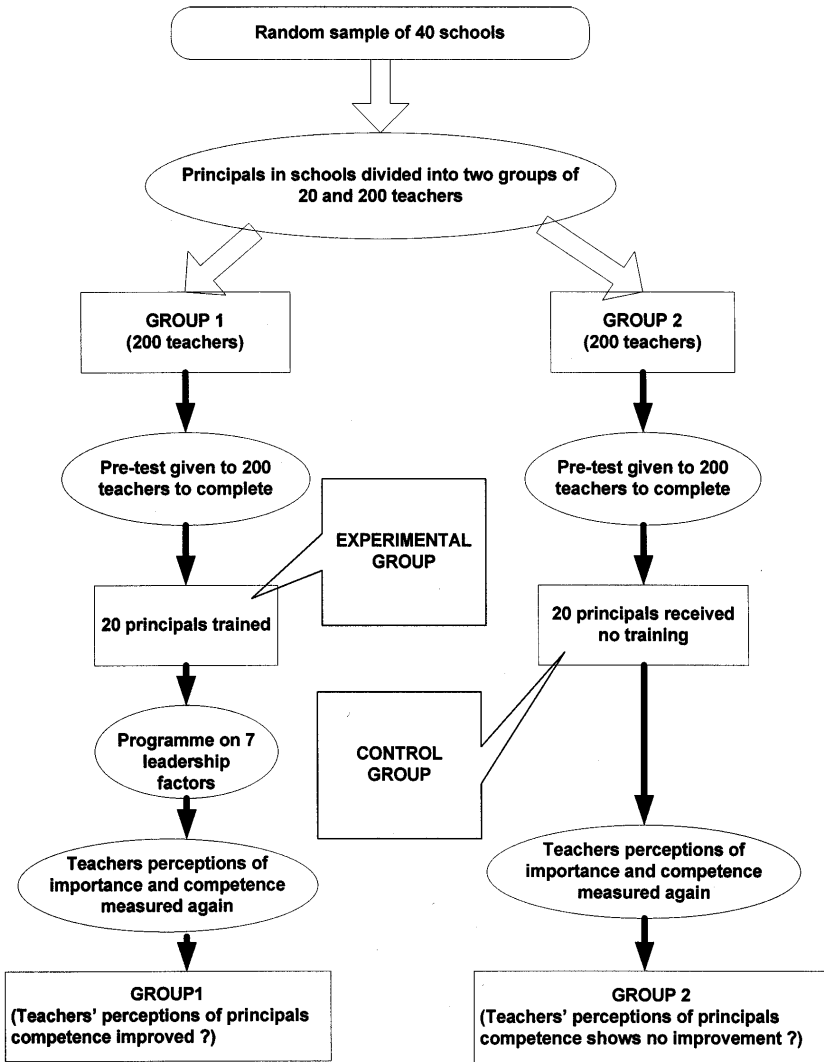

Figure 2 A simplified diagram of the experimental procedure followed for pre-and post-tests

group only. The teachers' perceptions regarding the importance with respect to the seven leadership dimensions showed no statistically significant differences on any of the leadership dimensions. The teachers of the principals who were exposed to the intervention programme and belonged to the experimental groups thus had the perception that the competence of their principals regarding the dimensions of holistic leadership had improved. The teachers belonging to the control group had no such perception. It thus appears that the intervention programme resulted in a significant improvement in the perceived competence in the seven leadership dimensions of the 20 principals who were exposed to the intervention programme.

Table 2 Pre-and post-test analyses regarding the importance and competence of school principals indicating significant differences of experimental and control groups with respect to the seven dimensions of leadership

Factor	Group	Importance			Competence		
		Pre-test (\bar{x})	Post-test (\bar{x})	<i>P</i>	Pre-test (\bar{x})	Post-test (\bar{x})	<i>P</i>
Professionally	Exp.	3.05	3.04	0.385	2.74	2.91	0.006**
Inviting culture	Cont.	3.03	3.02	0.820	2.90	2.92	0.385
Effective communication	Exp.	3.36	3.40	0.274	2.96	3.18	0.000**
Ethical foundation	Cont.	3.32	3.35	0.385	2.95	2.98	0.388
Vision of excellence	Exp.	3.49	3.53	0.252	2.91	3.17	0.000**
Followership	Cont.	3.50	3.52	0.386	2.92	2.96	0.152
Personal mastery	Exp.	3.45	3.51	0.372	3.02	3.11	0.032*
Authentic collaboration	Cont.	3.48	3.50	0.382	3.03	3.08	0.251
	Exp.	3.41	3.43	0.122	2.95	3.13	0.007**
	Cont.	3.43	3.45	0.383	2.97	3.01	0.245
	Exp.	3.51	3.57	0.573	3.16	3.43	0.000**
	Cont.	3.53	3.56	0.350	3.16	3.18	0.252
	Exp.	3.33	3.35	0.233	2.91	3.11	0.002**
	Cont.	3.35	3.37	0.235	2.92	3.95	0.253

N (Exp.) = 190; *N* (Cont.) = 160; Exp. = Experimental group; Cont. = Control group

* $p \geq 0.01$ and $p \leq 0.05$; ** $p \leq 0.005$

Using R^2 for interpretation of pre- and post-test results

The coefficient of determination (R^2) is a measure of the amount of variability in one variable that is explained by the other (Field, 2009). This is best shown by plotting the pre-test mean scores of the importance and post-test categories using a scatter-plot as is shown in Figure 3:

The R^2 value of 0.994 indicates that 99.4% of the variance in the pre-test importance means can be explained by the post-test importance means. The two variables are highly correlated ($r = \sqrt{0.994} = 0.997$). The perceptions of the respondents therefore did not change significantly between the pre-and post tests regarding the importance of the dimensions of holistic leadership. If one assumes that all the independent variables in Section A of the questionnaire remained more or less the same (the respondents were the same and the time period was relatively short) then the respondents' perceptions about *the importance of the holistic leadership on pre-and post-test remained virtually the same*.

When one plots the competence means of pre- and post-tests then the scatter plot in Figure 4 is obtained.

The R^2 value of 0.070 indicates that only 7% of the variance in the pre-test competence means can be explained by the post-test means. Hence 93% of the variance in the post-test had to be due to other variables. As the respondents for pre- and post-tests were the same then it is likely that the *intervention programme had a significant influence on the respondents' perceptions about their principals' holistic leadership*. The research hypothesis is thus accepted.

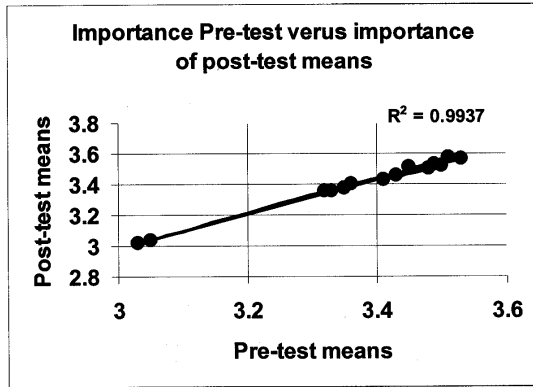

Figure 3 Scatter plot of importance of pre- and post-test means

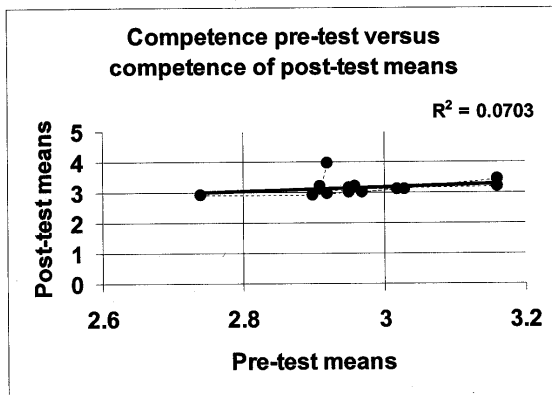

Figure 4 Scatter plot of competence of pre- and post-test means

Note that it is not stated that the intervention programme was the cause of the change but only that the substantive effect (effect size) of the pre-competence test on the post-competence test was not important and one is thus to a large extent eliminating the influence of the one competence test on the other. To change the perceptions of the same teachers on the same principal's holistic leadership in such a short period of two months may indicate that the intervention programme was the independent variable mainly responsible for this.

Conclusion

One of the most pertinent findings of this research was that principals who were exposed to the intervention programme regarding the seven dimensions of holistic leadership were perceived by their teachers to be more competent than their counterparts who were not exposed to the programme. These principals thus have a greater probability of impacting positively on their schools.

The holistic model presents a schematic representation and the various pathways give a visual portrayal of the relationship among the dimensions investigated. Such a model is a powerful mnemonic. One of the leaders of a group involved in the intervention programme worded it rather well when she indicated that it seemed to them that

“if a vision of excellence is based on an ethical foundation of improving learner achievements, a leader will need to effectively communicate such a vision to all concerned. A leader cannot achieve a vision of excellence on his/her own and hence the creation of a climate conducive to professional development and collaborative efforts to enhance commitment from all teachers is important if one is to empower your followers towards a common goal. In all of this the leader must use the personal mastery skills and utilize the passion and teaching skills that elevated him/her to the leadership position in the first place. Leadership is more than just the sum of its constituent pathways”.

The holistic model presented is a good starting point as it can be contextualised to the school where the leader is situated. However other possible pathways between the various dimensions need to be investigated.

The follow-up research to establish the sustainability of the training on the performance of principals, as viewed by teachers over a longer period, is another area for further investigation.

References

- Arbuckle JL 2007. *Amos 16.0 User's guide*. Chicago: SPSS, Inc.
- Baldwin TT & Patgett MY 1994. Management development: a review and commentary. In: Cooper CL & Robertson IT (eds). *Key reviews in managerial psychology*. New York: Wiley.
- Beare H 2001. *Creating the future*. London: Routledge/Falmer.
- Beeka A 2009. *The school principal and Heptaholistic leadership*. DEd thesis Johannesburg: University of Johannesburg.
- Brauckmann S & Pashiardis P 2011. A validation study of the leadership styles of a holistic leadership theoretical framework. *International Journal of Educational Management*, 50:11-32.
- Burns JM 1978. *Leadership*. New York: Harper Torchbooks.
- Caldwell BJ 2006. *Re-imagining Educational Leadership*. Victoria: ACER Press.
- Charlton G 1993. *Leadership: The Human Race*. Pretoria: Juta.
- Clarke A 2007. *The handbook of school management*. Cape Town: Kate McCullum.

- Creswell JW 2003. *Research design: Qualitative, quantitative and mixed approaches*. Thousand Oaks: SAGE.
- Department of Education 2006. *Annual Statistical Data: 2006*. Cape Town: Government Printer.
- Department: Public Service and Administration (nd). *Batho Pele*. Available at <http://www.dpsa.gov.za/batho-pele/Principles.asp> (accessed 12 August, 2010).
- Dzvimbo P 1996. New paradigms for principals. *The Teacher*, 1:15.
- Edwards E & Lawler H 1994. Total quality management and employee involvement: are they compatible? *Academy of Management Executive*, 8:68-76.
- Field A 2009. *Discovering statistics using SPSS*. 3rd edn. London: SAGE.
- Fullan M 2005. *The meaning of educational change*. New York: Teachers College Press.
- Gilbert RG 1993. Employee empowerment flows and practical approaches. *Public Manager*, 22:45-48.
- Grobler BR & Van der Merwe MP 1996. *The components of Educational Leadership*. Paper delivered at the International Education Law Conference, Potchefstroom, South Africa, June.
- Gronn P & Rawlings-Sanaei F 2003. Recruiting school principals in a climate of leadership disengagement. *Australian Journal of Education*, 47:172-184.
- Heiman G 2001. *Understanding research methods: An integrated introduction for psychology*. 2nd edn. New York: Houghton Mifflin
- Hersey P & Blanchard K 1989. *Management of Organizational Behaviour*. 2nd edn. New Jersey: Prentice Hall.
- Litterer JA 1993. *The analysis of Organizations*. New York: John Wiley.
- MacBeath J 2007. Leadership as subversive activity. *Journal of Educational Administration*, 45:242-264.
- McEwan EK 2003. *Seven steps to effective Instructional Leadership*. Thousand Oaks: Corwin Press.
- McMillan JH & Schumacher S 2004. *Research in Education. A conceptual introduction*. New York: Longman.
- Modiba SN 1997. *Leadership styles of school principals in three selected secondary schools in the Northern Province*. MEd dissertation. Johannesburg: Rand Afrikaans University.
- Moller J 2005. Framing successful school leadership as a moral and democratic enterprise. *Education research and perspectives*, 32:43-56.
- Northhouse PG 2004. *Leadership: Theory and Practice*. Thousand Oaks: SAGE.
- Nxumalo JD 2001. *Authority and discipline as responsibilities of the teacher*. DEd thesis. Johannesburg: Rand Afrikaans University.
- Pauwe J & Williams R 2001. Seven key issues for management development. *Journal of Management Development*, 20:90-105.
- Phillips DC 2006. *Perspectives on learning*. New York: Teachers Press.
- Pounder JS & Coleman M 2002. Women-better leaders than men? In general and Educational Management it still "all depends". *Leadership & Organizational Journal*, 23:122-133.
- Scheerens J & Bosker RJ 1997. *The foundations of educational effectiveness*. Oxford: Pergamon.
- Sergiovanni TJ 1990. Adding value to leadership gets extra-ordinary results. *Educational Leadership*, 25:23-27.
- Sergiovanni TJ 2005. *Strengthening the heart-beat: Leading and learning together in schools*. San Francisco: Jossey-Bass.
- Sikula AE 1993. *Management and Administration*. New York: Bell and Howell.
- Soudien C 2007. The "A" factor: Coming to terms with the question of legacy in South African Education. *International Journal of Education Development*, 27:182-193.
- South Africa Republic 1996. *The Constitution of the Republic of South Africa*. Pretoria: Government Printer.
- South Africa Republic 1997. *White paper on transformation of Public Service of 1997*. Department of Public Service and Administration. Pretoria: Government Printer.
- South Africa Republic 1999. *Public Service Regulation of 1999*. Department of Public Service and Administration. Pretoria: Government Printer.
- South Africa Republic 2000. Promotion of the Administrative Justice Act No.3 of 2000. *Government*

Gazette Vol.416, No. 20853..Pretoria: Government Printer.

South Africa Republic 2001. *Public Service Regulation of 2000.* Department of Public Service and Administration. Pretoria: Government Printer.

Taylor N, Muller J & Vinjevold P 2004. Leadership behaviour of the high school principal and assistant principal for instruction. *The High School Journal*, 78:172-182.