

Art. # 1424, 13 pages, <https://doi.org/10.15700/saje.v37n4a1424>

## Structural determinants of students' employability: Influence of career guidance activities

 **Oluyomi Susan Pitan**

School of Accounting, Economics and Finance, College of Law and Management Studies, University of KwaZulu-Natal, Durban, South Africa  
yomipitan@yahoo.com; pitano@ukzn.ac.za

 **Sulaiman Olusegun Atiku**

School of Management Information Technology and Governance, College of Law and Management Studies, University of KwaZulu-Natal, Durban, South Africa

At a time of continuous economic uncertainty and a highly competitive labour market, it is crucial for undergraduates to be more pro-active about their future careers. This study investigates the structural influence of career guidance activities on university students' employability in Nigeria. Data was collected from 600 final-year undergraduates from four universities in the South-West geopolitical zone, with the use of an adapted questionnaire. The quantitative data were subjected to exploratory and confirmatory factor analysis to ensure factorial validity of the research instrument, and subsequently structural equation modelling (SEM). SEM was performed by means of Analysis of Moment Structures (AMOS Graphics, version 24) in testing the DOTS model in Nigeria. Results confirm the positive influence of career guidance activities on students' employability. On the dimensions of career guidance activities, self-awareness and opportunity awareness have the greatest influence on students' employability, followed by decision-making skills, and then transition learning skills. To enhance undergraduates' employability upon graduation, universities should strengthen their efforts in developing appropriate strategies so as to engage undergraduates with the four dimensions of career guidance activities depicted in the DOTS model.

**Keywords:** career guidance activities; decision learning; employability; Nigeria; opportunity awareness; self-awareness; structural equation modelling; transition learning; undergraduates

### Introduction

The world today, including the world of employment, is in the process of changing from the industrial age to the information and communication age, often referred to as the knowledge-based economy (Pitan, 2015; Prelovský, n.d.). An implication of this change is that it is no longer enough for new graduates to have a good degree, but it also becomes crucial for them to acquire a range of general, and employability and flexibility skills so that they can adjust to new modes of production organisation inherent to the globalisation of the economy (Fallows & Steven, 2000; Guichard, 2001). Employability skills are the skills, knowledge, attributes and attitudes that will enable students to obtain, maintain and change jobs (or generate self-employment) in which they can be fulfilled and successful (Dacre Pool & Sewell, 2007; Pitan, 2016b). Employability, being one of their central objectives (Finch, Hamilton, Baldwin & Zehner, 2013), universities are expected to help students to prepare better for transition to the labour market by putting in place structures that will enhance students' employability and flexibility in the world of work (Harvey & Contributors, 2003; Pitan, 2016a). Career guidance, which is the main focus of this article, is one such structure (see Crişan, Pavelea & Ghimbuluţ, 2015; Dacre Pool & Sewell, 2007; Jackson & Wilton, 2016b; Kinash, Crane & Judd, 2016; Organisation for Economic Co-operation and Development [OECD], 2003; Pitan, 2016b; Watts, 2006, 2013). According to Law and Watts (2003) and Watts (2006), career guidance refers to all activities that consist of planned experiences designed to facilitate the development of self-awareness, opportunity awareness, decision learning and transition learning skills.

By giving appropriate attention to enhancing students' employability through career guidance, the universities are potentially responding to students' motivations for entering university, as for many students, a very important part of their motivations is future employment prospects (Adedeji & Oyebade, 2016; Archer & Chetty, 2013; Taylor & Hooley, 2014; Watts, 2006). At the same time, the universities are responding to policy concerns, such as justifying huge investment by government in higher education, which is aimed at the development of the country's human capital, and achieving social-equity goals by increasing access to education for disadvantaged groups. In achieving their social-equity goals, universities are not only paying attention to ensuring the participation of these groups in university education, but also enhancing their subsequent success in the labour market and in life generally (Watts, 2006). Furthermore, there are indications that even the most capable graduates may not do well in recruitment and selection processes, either because they are ignorant of the skills and qualities demanded by industry, or they cannot adequately prove they have acquired such skills while in the university (Wilton, 2014).

Several studies (e.g. Bennett, Richardson & MacKinnon, 2016; Bridgstock, 2009; Dacre Pool & Sewell, 2007; Knight & Yorke, 2003; Pitan, 2016a, 2016b) have identified factors that enhance students' employability, some of which are academic skills, generic skills, extracurricular activities, work experience, personal

development planning and career guidance activities. Considering the relationships among all these factors, which enhance employability, career guidance was found to have the strongest relationship with all the other components of employability (Pitan, 2016a), which implies that career guidance plays a pivotal role in conjunction with other components of employability to achieve the desired goal. The implication of this central role is that career guidance, which is a subset of employability, enables students to effectively utilise the skills and knowledge gained in the process of being in the university. Supporting this evidence is the career constructionist perspective, which emphasises flexibility, employability, and lifelong learning as a paradigm shift for career intervention in the 21st century (Savickas, 2012; Savickas, Nota, Rossier, Dauwalder, Duarte, Guichard, Soresi, Van Esbroeck & Van Vianen, 2009). Corroborating this is Guichard (2001), who believes that one of the main objectives of career guidance education is to enable young people acquire a range of general *employability* and *adaptability* skills, so that they can adapt to changes in the world of work.

Career guidance assists students to understand the labour market (OECD, 2003), and to reflect on their interests, ambitions, abilities and qualifications. As Dacre Pool and Sewell (2007) noted, after acquiring so much knowledge, understanding and skill at university, students need guidance on the best way to describe their achievements to potential employers and to explain how they will be of benefit, when writing applications and their Curriculum Vitae (CVs), as well as when attending interviews. According to these authors, there is little to be gained in training students if, at the end of the day, they cannot identify a market in which to advertise their developed employability, especially when there is so much uncertainty and competition in the labour market (Jackson & Wilton, 2016a). Therefore, to minimise the difficulties graduates face in the unpredictable and highly competitive labour market (Ariffin & Saedahtinnur, 2012), there is the need for undergraduates to acquire knowledge on the best way to explore the labour market, identify the available opportunities, learn how to package themselves well to prospective employers, and how to make their career decisions (Pitan, 2016b). It is important, therefore, that universities not only develop the academic and generic skills demanded by industry, but also empower undergraduates with the ability to articulate their skills to potential employers (Jackson & Wilton, 2016a).

Realising the importance of career guidance in enhancing students' employability, some studies (Bridgstock, 2009; Pitan, 2016b; Talib, Salleh,

Amat, Ghavifekr & Ariff, 2015) have recommended the integration of career guidance education into the school curriculum from first year. This stems from the observations that undergraduates are either not aware or not well informed about the requirements of employability. Many of them do not realise the need for career services and do not independently give their future careers any active thought until their final year (Dickinson & Griffiths, 2015; Pitan, 2010, 2016a; Pitan & Adedeji, 2014; Walker & Fongwa, 2016). The early introduction of career guidance into the school curriculum will therefore, assist the students by creating an awareness in them, helping them to get familiar with the need to develop employability skills early enough (Kinash et al., 2016). As Talib et al. (2015) have confirmed, early exposure to module-based, career-related programmes will significantly enhance career planning ability, self-efficacy, and career maturity among students. These positive skills are crucial elements to employability.

Despite the obvious theoretical appeal of a link between career guidance activities (using DOTS model) and employability, it is surprising to note that there are only a few empirical studies that have been conducted, particularly in Nigeria (Ariffin & Saedahtinnur, 2012; Bridgstock, 2009; Pitan, 2016a; Taylor & Hooley, 2014). However, as suggested by Ariffin and Saedahtinnur (2012), it is necessary to provide empirical evidence that career guidance can significantly impact undergraduates' employability. Also, there is a dearth of empirical analysis of the DOTS model in Africa using structural equation modelling, which is the uniqueness of this study. Based on this challenge, this study tries to empirically assess the influence of career guidance activities on undergraduates' employability in Nigeria.

For the purpose of this study, career guidance comprises planned activities designed by the university to facilitate the development of self-awareness, opportunity awareness, decision learning and transition learning in students, as identified by the DOTS model developed by Law and Watts (2003). While employability is defined as the ability of undergraduates to possess and exhibit the skills, knowledge, attributes and attitudes not only to secure a first job or start a business, but also to remain employable throughout life (Dacre Pool & Sewell, 2007; Pitan, 2016b; Watts, 2006).

#### Objectives of the Study

This study seeks to conduct a structural investigation of the relationship between career guidance activities and undergraduates' employability upon graduation. In addition, this study attempts to identify the exogenous variable

(among the four dimensions of the DOTS model) that plays a prominent role in the structural model determining students' employability in Nigeria.

#### Theoretical Model

This study specifically utilises the 'DOTS' theoretical model developed by Law and Watts (2003) and supported by Rae (2007). The DOTS model is notable as a career guidance framework for its widespread use and suitability in incorporating employability into the undergraduate curriculum (Dacre Pool, Qualter & Sewell, 2014; Jackson & Wilton, 2016a; Rae, 2007). It is specifically selected for this study because it has endured over several years of implementation in the higher education sector (Dacre Pool & Sewell, 2007; McIlveen, Brooks, Lichtenberg, Smith, Torjul & Tyler, 2011). Secondly, it can be easily represented in a concise format, and lastly, it is readily understood and applied by individuals not versed in the principles of career guidance (Dacre Pool & Sewell, 2007; McIlveen et al., 2011).

As has been identified in the definition of career guidance above, the DOTS model, according to Law and Watts (2003), and Watts (2006), consists of four components. These are: *self-awareness skills* (the ability to identify and articulate personal interests, skills, abilities, values and motivations as they affect career plans); *opportunity awareness skills* (knowing what work opportunities exist and what their requirements are); *decision making skills* (being able to weigh up personal factors to make a well-informed and realistic career plan); and *transition learning skills* (understanding how to seek and secure opportunities in terms of having job-search and self-presentation skills). These four components individually and collectively provide a framework for organising and ordering career learning (McIlveen et al., 2011).

To develop and implement the DOTS model at a practical level within the university programme, Rae (2007) proposed some key components as a guiding principle for career guidance activities to be included in the design of undergraduate programmes. In this study, these components in Rae's model informed the criteria for measuring the four variables in the DOTS model. According to Rae (2007), these components are:

#### *Personal development planning*

These are all forms of support and encouragement given to students, which assist them in reflecting on and evaluate their acquired learning experiences in order to improve performance.

#### *Applied learning*

These are programmes that enable students to make connections between theoretical academic-based learning, and to apply and transfer this knowledge and skills into the workplace. Such programmes include exposing students to real-world activities such as visits to local employers, listening to employers via seminars about employment opportunities and skill requirements, witnessing alumni visits to talk about their career paths and opportunities in their companies, interactive and simulation-based learning, etc.

#### *Work-based learning (WBL)*

This is an educational strategy that provides students with real-life work experiences, where they can apply academic and technical skills and develop their employability. Examples of possible work-based learning activities, as suggested by Rae (2007), are short-term work experience placements of 6–12 weeks; a full academic-year work experience placement; relevant part-time, casual or vacation work; self-employment or freelancing; voluntary, community or social enterprise work activity; and leadership or organisation of student clubs, sports activities or societies.

#### *Career development learning*

These are career development activities that involve the identification of career goals and pathways for achieving them, and the acquisition of skills and competencies to achieve one's aspirations (Jackson & Wilton, 2016a). Career development learning activities include training on CV preparation, job searching, job applications and interview preparation, self-presentation and communications skills.

#### *Model specification and hypotheses*

As illustrated in Figure 1, decision making, opportunity awareness, self-awareness and transition learning could be referred to as the exogenous latent variables investigated in this study. Students' employability is the endogenous latent variable. The items measuring each latent variable are illustrated with boxes in the measurement and structural models. To subject the conceptual framework presented in Figure 1 to empirical analysis, this study hypothesised that:

*H*<sub>1</sub>: decision making skills have a significant influence on students' employability;

*H*<sub>2</sub>: opportunity awareness and self-awareness skills significantly influence students' employability;

*H*<sub>3</sub>: transition learning skills have a significant influence on students' employability.

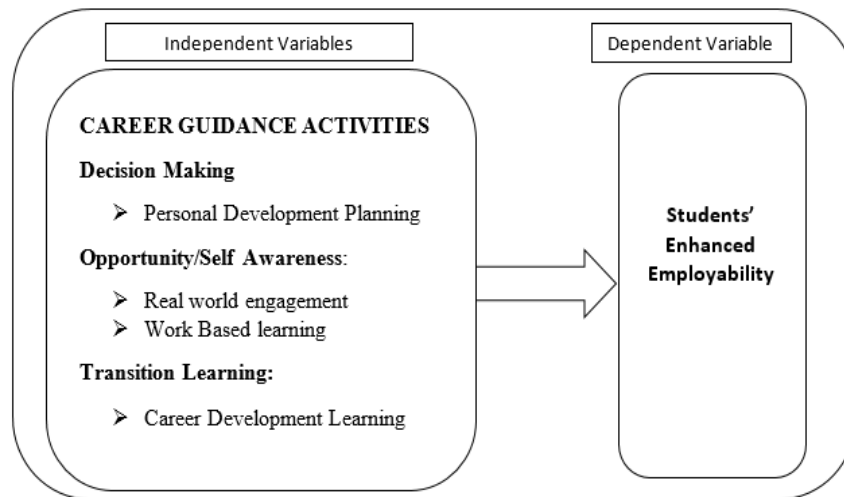

**Figure 1** Conceptual framework

*Note.* Source: Adapted from Law and Watts (2003:1–4) and Rae (2007:613–615).

### Methodology

This article adopted a survey research design to determine structurally students' employability by exploring the influences of decision-making, opportunity awareness, self-awareness and transition learning in selected Nigerian universities. A correlational and explanatory research design was incorporated to objectively subject the quantitative data to multivariate statistical analysis (Byrne, 2010). The multivariate statistical analyses engaged in this study are explained under data analysis procedure.

### Sample

The population of interest for this study was all final year university students in Nigeria. The sample consisted of 600 of these final year students from four universities in the South-West geopolitical zone of Nigeria. The 600 students consisted of 150 students from each of the four universities. The four universities were made up of two federal universities, as well as one state, and one private university. The students were chosen from different fields of study, which were initially nine at the first phase of the coding process. At the final stage of coding, these were consolidated into four, which are: Arts/Education/Social Sciences, Pharmacy, Engineering/Technology, and Sciences.

### Sampling Procedure

The selection of the four universities from one geopolitical zone (South-West) out of the six in Nigeria was based on a purposive sampling technique. In addition, the choice of final year university students as the study population was purposive. The final year students were purposely chosen because they have spent more time in the university, in which case they were likely to have better insight into questions on career guidance activities and employability. It is also believed that

students' career preparation activities increase at this level. The 150 final year students from each of the universities who eventually participated in the study were randomly selected.

The research instrument was administered during the first semester of 2015/2016 academic session by one of the researchers and four trained research assistants. The measure was responded to as a paper-and-pencil version. Out of the 600 questionnaires that were distributed, 463 (77.2%) were returned. Out of the 463 respondents, there were 222 from the federal universities, 141 from the state university, and 100 from the private university. In terms of gender, there were 265 male and 198 female respondents.

### Measures

Data was collected with the use of a five-point Likert rating scale, ranging from "1 strongly disagree" to "5 strongly agree" questionnaire. The items on the instrument were designed to reflect activities that link career guidance activities to employability as identified during the literature review and, particularly, as suggested by the DOTS model outlined by Law and Watts (2003), Rae (2007) and Watts (2006). These activities were listed as 24 items, out of which 21 were designed to measure career guidance activities and three were used to measure students' employability.

### Decision making

The construct *decision making* was measured by six items, and two items were expunged during exploratory and confirmatory factor analysis to meet/surpass the threshold average variance extracted. These four items are: Item 1 - I have self-awareness of the skills that I have developed and I regularly review my progress against target I set for myself; Item 2 - I reflect on and assess myself on acquired learning experiences; Item 3 - I continu-

ally seek new opportunities and critically review the opportunities available to me; Item 4 - I have developed a clearer vision of my career path and long-term goals. These four items as itemised in Table 1, produced a Cronbach's alpha coefficient of 0.841.

#### *Opportunity/Self-awareness*

The second construct *opportunity/self-awareness* in line with the DOTS model was assessed on two dimensions, namely: (1) real-world engagement; and (2) work-based learning. Five items were instrumental in eliciting information regarding real-world engagement from respondents in selected Nigerian universities. Two items were deleted to ensure convergent and discriminant validities as illustrated in Table 1 and Figure 2. The remaining three items on the scale are: Item 1 - I have witnessed alumni visit to talk about their career paths and opportunities in their company; Item 2 - I have listened to employers via seminars about employment opportunities and skill requirements for these opportunities; Item 3 - I have experienced employers' participation/attendance in programme delivery or project presentation. The measure of internal consistency of these remaining three items produced a Cronbach's alpha coefficient of 0.821.

Five items were valuable in collecting information concerning work-based learning from the respondents. One item (WBL 2) on the scale was deleted during exploratory factor analysis, and the Cronbach's alpha coefficient for the remaining four items measuring work-based learning was 0.813. Examples of items remaining on the scale are: Item 1 - my degree experience at the university has exposed me to work experience through internship/work placement; and Item 3: my degree has developed my awareness of workplace structures and practice.

#### *Transition learning*

The third construct *transition learning* was assessed in this study using five items, and one item (TL 2) was deleted to avoid convergent and discriminant validities issue. The remaining four items produced a Cronbach's alpha coefficient of 0.833. Examples of these items are: 1 - my university has made the services of career counsellors and/or advisors available to me; and 2 - my university has given me the knowledge to produce an up-to-date curriculum vitae (CV) targeted to job applications I might make.

#### *Students' employability*

The fourth construct measures *students' perceived employability* using three reliable items judging from the Cronbach's alpha coefficient of 0.867. These items are: item 1: I have good knowledge about the requirements of my future career; item 2: I am aware of the employment opportunities open to me; Item 3: I feel confident that I will be able to

find appropriate work after leaving the university. All composite reliability (CR) and Cronbach's alpha coefficients are greater than 0.7, confirming the internal consistency of the construct measures. According to the rule of thumb provided by Pallant (2011), the instrument used in measuring the constructs was reliable. To ascertain validity, the instrument was examined and modified after which it was certified for use by colleagues and senior academics who are experts in the field of data analysis. Statistical validity was also performed using exploratory and confirmatory factor analysis.

#### *Ethical Issues*

The authors applied for ethical clearance from the Humanities and Social Sciences Research Ethics Committee, University of KwaZulu-Natal, Durban, South Africa. After due processes were followed and all the requirements (including the collection of gatekeepers' letters from the four sampled universities) were met, the application was granted full approval. The ethical clearance certificate (with Protocol reference number HSS/0866/015) was issued on November 10, 2015 to proceed with the study in the four universities.

#### *Rigour of the Study*

To ascertain validity, the instrument was examined and modified, after which it was certified for use by colleagues and senior academics, who are experts in the field of data analysis. Preliminary data screening was conducted to fill up the missing values, and checking outliers using Mahalanobis distance and Cook's distance and leverage values. Pearson's bivariate correlation was used to test against violation of multicollinearity assumptions. The tolerance ( $< 1$ ) and VIF ( $< 10$ ) values in the coefficients table in the multiple regression outputs reaffirm non-violation of multicollinearity assumptions. Exploratory factor analysis (EFA) was also run to validate the key factors by selecting a maximum likelihood option, using an oblique Promax rotation method.

Testing the DOTS model in Nigeria, the following model fit indices were used to assess the fitness of measurement and structural models. The chi-square, degree of freedom and  $p$  values were the first sets of model fit indices considered in this study. The normed chi-square test values were useful in determining model fit, which is the chi-square value – degree of freedom ratio; it should considerably be less than 5 (Hooper, Coughlan & Mullen, 2008). Three incremental model fit indices used were the Tucker-Lewis Index (TLI), the Incremental Fit Index (IFI) and the Comparative Fit Index (CFI). The IFI and Goodness Fit Index (GFI) ranged between 0.0 and 1.0 with values between 0.9 and 1.0 indicating a good fit (Byrne, 2010; Hooper et al., 2008). The root mean square error of approximation (RMSEA) and PCLOSE were also

reported in this study to examine the fitness of the proposed model to the sample data.

#### Data Analysis

The Statistical Package for Social Sciences (SPSS) version 24 was engaged in conducting the preliminary analysis of the quantitative data. The Structural Equation Modelling (SEM) as a multivariate statistical analysis was achieved in this article using Analysis of Moment Structure (AMOS) Graphic version 24. AMOS is a covariance based SEM instrumental in testing the DOTS model. SEM was instrumental in determining students' employability by examining the

influences of *decision making, opportunity awareness, self-awareness* and *transition learning*.

#### Results

The factors extracted from the research instrument used in assessing the influences of *decision making, opportunity awareness, self-awareness, and transition learning skills* on students' employability are presented in Table 1. The descriptive statistics, as well as inferential statistics such as item-total correlations, Cronbach's alpha coefficients, eigenvalues and variances explained by the extracted factors are also illustrated in Table 1.

**Table 1** Exploratory factor analysis

Item	Factor					M	SD	Corrected Item-Total Correlation
	1	2	3	4	5			
DM 2	.877					3.99	.913	.599
DM 4	.839					3.98	1.030	.584
DM 3	.803					3.87	.950	.608
DM 1	.747					3.92	.970	.617
RWE 4		.912				3.41	1.245	.408
RWE 3		.805				3.51	1.156	.573
RWE 2		.735				3.62	1.126	.624
TL 4			.884			3.25	1.141	.619
TL 3			.854			3.51	1.093	.631
TL 5			.713			3.38	1.167	.628
TL 1			.664			3.26	1.134	.518
WBL 1				.947		4.04	1.127	.425
WBL 3				.759		3.77	1.003	.513
WBL 4				.729		3.66	.999	.629
WBL 5				.638		3.59	1.099	.580
SE 2					.903	3.72	1.005	.641
SE 3					.846	3.81	1.068	.643
SE 1					.829	3.90	1.070	.676
Cronbach's $\alpha$	.841	.821	.833	.813	.867			
Eigenvalue	7.5	1.7	1.3	1.2	1.1			
Variance (%)	39.16	7.13	4.89	4.36	4.14			

Note. \*KMO = 0.914;  $X^2 = 4192.896$ ;  $df = 153$ ;  $p < 0.001$ ; Total variance explained = 59.7%. DM = Decision making; RWE = Real world experience; TL = Transition learning; WBL = Work-based learning; SE = Students' employability. Source: Emerged from statistical analysis.

The first factor (1) extracted measures decision making capabilities informed by personal development planning. The majority of the total variance was explained by decision making as evident in Table 1, which was 39.16 percent. The second factor (2) extracted elicits information regarding students' real-world engagement, explaining a 7.13% level of variance. The third factor (3) extracted explained 4.89% of the variance by measuring transition learning skills inculcated through career development learning. The fourth factor (4) illustrated in Table 1 explained a 4.36% variance. This factor measures work-based learning activities as related to students' enhanced employability. Finally, the fifth factor (5) extracted elicited students' perceptions of employability in relation to career guidance activities in Nigerian universities. To maintain an acceptable level of the average variance extracted and ensure that no items were cross-loaded, the following items were expunged.

Two items were deleted from the six items measuring decision making, as well as two items from the scale measuring real-world engagement. One item each was deleted from transition learning, and work-based learning. The Kaiser-Meyer-Olkin value of 0.914 indicates a superb sample size (463) adequacy. The Bartlett Test of Sphericity is highly significant ( $p < 0.001$ ), which shows that EFA is appropriate.

Factorial validity of the instrument used in the measurement model was confirmed through convergent and discriminant validity). Convergent validity was ascertained from the Average Variance Extracted (AVE) values, which were above the threshold of 0.5. Discriminant validity of the factors was conducted by comparing the square roots of AVE values to the correlations, as well as tests carried out to check items' cross loadings. Discriminant validity was confirmed by ensuring that the Maximum Shared Variance (MSV) and

Average Shared Variance (ASV) were less than the AVE. The square roots of AVE were greater than inter-construct/factor correlations, which was another confirmation of discriminant validity. The information provided in Table 1 and Table 2, as well as in Figure 2, are indications of the factorial validity of measurements used in this study.

The CFA model is presented in Figure 2,

whereby real-world engagement and work-based learning were converted into second-order CFA to form opportunity awareness and self-awareness in line with the procedure provided by Byrne (2010). This procedure was essential to effectively subject the DOTS model to empirical analysis in Nigeria, by observing the model in relation to the sample data using conventional model fit indices.

**Table 2** Factorial validity of the instrument

Factor	CR	AVE	MSV	TL	DM	RWE	WBL	SE
Transition learning (TL)	0.842	0.577	0.426	0.759				
Decision making (DM)	0.849	0.585	0.445	0.574	0.765			
Real-world activities (RWA)	0.808	0.587	0.371	0.584	0.510	0.766		
Work-based learning (WBL)	0.806	0.512	0.445	0.525	0.667	0.484	0.716	
Students' employability (SE)	0.867	0.686	0.426	0.653	0.634	0.609	0.569	0.828

Note. All correlations are significant at ( $p < 0.001$ ). Diagonal are the square roots of the AVE (Average Variance Extracted). Source: Emerged form statistical analysis.

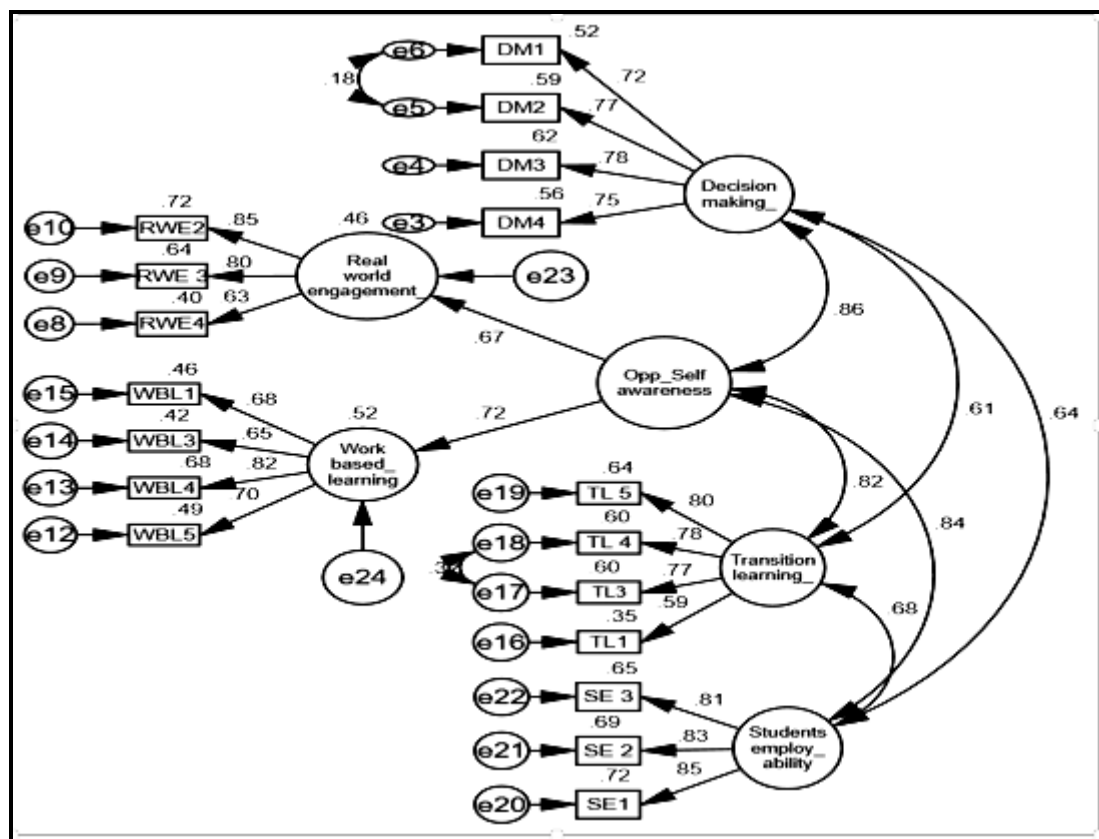

**Figure 2** Measurement model for career guidance activities and students' employability

Note. CMIN = 232.688;  $df = 125$ ;  $p$ -value = 0.000 ( $< 0.001$ ); CMIN/ $df = 1.862$  ( $< 5$ ); GFI = 0.949 ( $> 0.90$ ); IFI = 0.974 ( $> 0.90$ ); TLI = 0.968 ( $> 0.90$ ); CFI = 0.974 ( $> 0.90$ ); RMSEA = 0.043 (below 0.05); PCLOSE = .903 ( $> 0.5$ ). Source: Emerged from statistical analysis.

As evident in Figure 2, opportunity awareness and self-awareness could be referred to as a second order latent variable, while the latent variables decision making, transition learning and students' employability are in the first-order. The fit indices presented below the measurement model in Figure 2 show a good fit of the measurement model to the sample data. The CFI value of 0.974, and other comparative fit indices are greater than 0.90, which

suggest an absolute fit. The RMSEA value of 0.043, which is less than 0.05, points to a perfect fit. All factor loadings presented in Figure 2 are significant at ( $p < 0.001$ ) and range from 0.52 to 0.86, which implies a statistical validity of the proposed model. The fit indices validate the four latent variables and their corresponding manifest variables. The fit indices and factor loadings validate the measurements of career guidance activities on

students' employability in Nigeria. The structural model determining students' employability from the influences of decision making, opportunity awareness and self-awareness, and transition learning in Nigeria is presented in Figure 3.

The fit indices illustrated in Figure 3 reveal a good fit of the structural model to the sample data at selected universities in Nigeria. Statistically, all

standardised regression weights (SRW) and factor loadings are significant at ( $p < 0.001$ ). Beyond being significant, the beta loadings (SRW) for the three independent variables are above 0.3 at  $p < 0.001$  significant level. This indicates that the strength of association between career guidance activities and students' employability ranges from medium to large relationship.

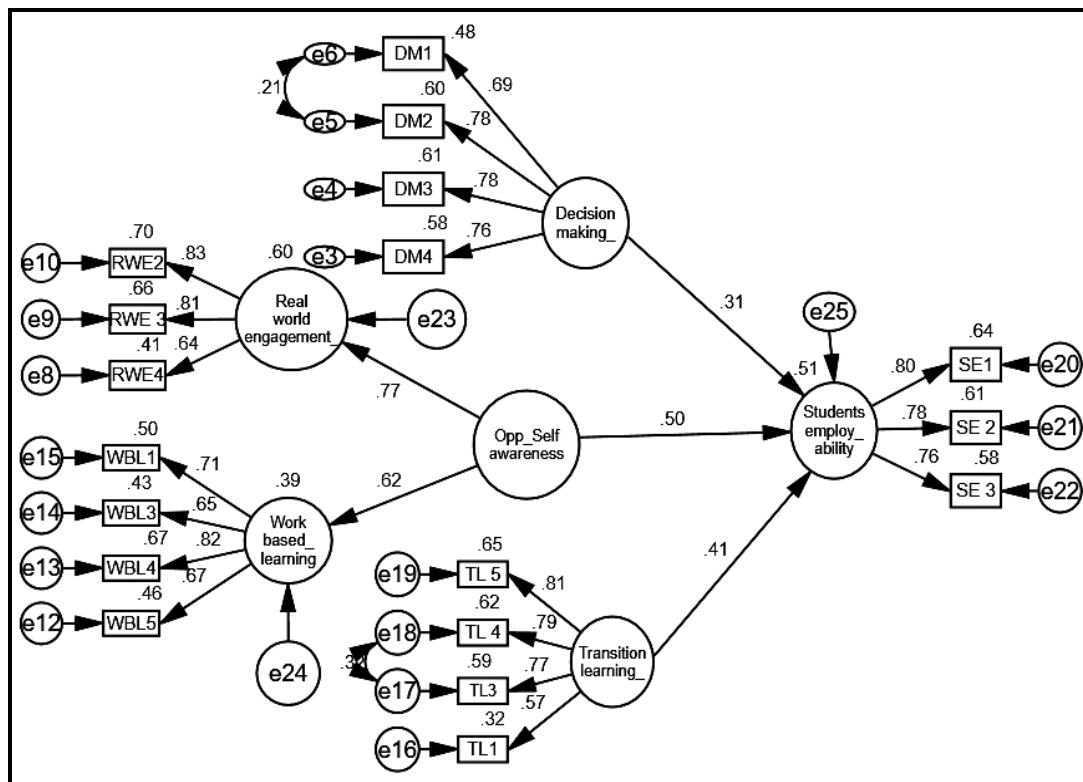

**Figure 3** Structural model revealing the influences of career guidance activities on students' employability  
*Note.* CMIN = 257.792;  $df = 128$ ;  $p$ -value = 0.000 ( $< 0.001$ ); CMIN/ $df = 2.014$  ( $< 5$ ); GFI = 0.906 ( $> 0.90$ ); IFI = 0.933 ( $> 0.90$ ); TLI = 0.924 ( $> 0.90$ ); CFI = 0.953 ( $> 0.90$ ); RMSEA = 0.049 (below 0.05); PCLOSE = .651 ( $> 0.5$ ). Source: Emerged from statistical analysis.

The standardised regression weight from decision making to students' employability is (SRW = 0.31,  $p < 0.001$ ), and this implies that decision making capabilities acquired through personal development planning has a positive influence on students' employability in Nigeria. This result supports the research hypothesis one ( $H_1$ ) based on the fact that there is a significant positive relationship between decision making and students' employability. Also, the SRW value of 0.31 shows that the strength of this relationship is medium.

The standardised regression weight from opportunity awareness and self-awareness to students' employability is (SRW = 0.50,  $p < 0.001$ ). A unit increase in the standard deviation of opportunity awareness and self-awareness results in a 0.50 increase in students' employability. This result indicates an enhanced students' employability through opportunity awareness and self-

awareness. A high level of opportunity awareness and self-awareness skills is associated with a higher level of students' employability in Nigeria. The beta loading from opportunity awareness and self-awareness to students' employability (SRW = 0.50,  $p < 0.001$ ) supports hypothesis two ( $H_2$ ) on the grounds that there is a positive relationship between opportunity awareness and self-awareness and students' employability in Nigeria. The size of the SRW (0.5) also implies that the degree of this relationship is large. Statistically, opportunity awareness and self-awareness is a better predictor of the variations in students' employability, judging from the beta loading (SRW) in relation to other exogeneous variables (decision making and transition learning). Therefore, opportunity awareness and self-awareness play a prominent role in the structural model presented in Figure 3.

The standardised regression weight from transition learning to students' employability is



( $SRW = 0.41$ ,  $p < 0.001$ ). This implies that transition learning skills inculcated through career development activities have a positive influence on students' employability in Nigeria. This result supports the research hypothesis three ( $H_3$ ), namely that there is a significant positive relationship between transition learning and students' employability in Nigeria. Empirically, a unit increase in the standard deviation of transition learning leads to a 0.41 increase in students' employability. Therefore, transition learning is positively associated with students' employability in Nigeria.

### Discussion

The findings of this study clearly show that all the four dimensions of the DOTS model of career guidance activities, namely self-awareness, opportunity awareness, decision making and transition learning skills, have a significant positive influence on university students' employability in Nigeria.

Remarkably, these results are in agreement with the conceptual model for the study and virtually with all employability models (Bridgstock, 2009; Dacre Pool & Sewell, 2007; Hillage & Pollard, 1998; Pitan, 2016b; Watts, 2006). The implication of this finding is that all career guidance activities as identified by the DOTS model are important elements in students' enhanced employability. Confirming the dimensions of the DOTS model in an African context may indicate that students are beginning to realise that the transition from school to work involves an active process, which has to be negotiated and worked at, just as Tomlinson (2007) observed among undergraduates in a UK university.

Considering the results of the relative influences of the four dimensions of career guidance activities, the activities geared towards the development of self-awareness and opportunity awareness skills have a superior influence on students' employability. These are followed by decision making skills, and then transition learning skills. These results are in line with the empirical studies of Ariffin, Raja-Abdullah, Baba and Hashim (2015), Ariffin and Saedahtinnur (2012) and McIlveen et al. (2011). Ariffin et al. (2015) and Ariffin and Saedahtinnur (2012) carried out their studies among hospitality students in Malaysia; they found that self-awareness, opportunity awareness and decision making skills have a greater influence on students' employability compared to transition learning. However, the results of the present study are slightly different to those of Jackson and Wilton (2016b), whose study sample comprised two sets of undergraduates from the United Kingdom (UK) and Australia. The study revealed variations in the influence of career guidance activities on perceived employability in the two countries. For Australian students, both decision-making and transition learning were found

to be associated with perceived employability, while in the UK, only opportunity awareness was found to have a positive association with perceived employability. The differences in the results of the present study and that of Jackson and Wilton (2016b) may be attributed to variations in countries and also, as Jackson and Wilton (2016b) noted, the variation may be due to differences in actual or perceived economic, health and labour market conditions among undergraduates. For example, undergraduates from developed economies like Australia may feel that there are opportunities in the labour market and, therefore, developing their employability is not about effectively identifying the opportunities but more about making effective decisions on which pathway to pursue, and presenting themselves appropriately during selection processes (Jackson & Wilton, 2016b). On the other hand, undergraduates from an African country and a developing economy like Nigeria may have perceived the scarcity of opportunities, and the intense competition for those few available. In this case, they need to especially enhance their self-awareness and opportunity awareness skills along with the other two dimensions of career guidance activities to be able to navigate successfully the world of work. Therefore, one may infer from this particular finding that the perceived and anticipated problem of employability and its management now informs students' understanding, and approaches towards the job market (Tomlinson, 2007).

The opportunity awareness and self-awareness skills dimension having the greatest influence on employability suggests that understanding one's strengths and weaknesses, and having knowledge of the labour market, is of utmost importance in shaping undergraduates' employability in Nigeria. Actually, opportunity awareness and self-awareness are basic in achieving one's career goals, because the more understanding one has of oneself and available opportunities, the more likely one is able to have personal definition of success and make informed decisions (Ghayur & Churchill, 2015). This result proves that the two variables, viz. work-based learning and real-world engagement under which the constructs opportunity awareness and self-awareness skills were measured, are dominant in enhancing students' employability. This finding is an extension of previous literature that identifies students' exposure to real-world engagement as the most essential component of enhanced students' employability (e.g. Creasy, 2013; Lowden, Hall, Elliot & Lewin, 2011; Mason, Williams & Cranmer, 2009; Pitan, 2016a). It also confirms the significance of work-based learning for graduate employability (Chillas, Marks & Galloway, 2015; Finch et al., 2013; Jackson & Wilton, 2016b; Lowden et al., 2011). However, Jackson acknowledged that for any type of work-based

learning to be a panacea for enhanced employability, attention should be paid to the length of the work experience. The implication of this result for universities is to emphasise activities that promote students' self-awareness and opportunity awareness. Such activities include encouraging students to conduct interviews with employers and conduct research into the employment market for their particular profession, and then to write a report of their findings with a discussion based upon disciplinary theory (McIlveen et al., 2011). Other relevant activities include students listening to employers about employment opportunities and the skills requirements for these opportunities, more practical classes, excursions (Pitan, 2016b), and creating diverse opportunities for students to gain relevant work experience (Rae, 2007).

The positive influence of decision making skills on undergraduates' employability in Nigeria indicates the significance of adequately developing critical career planning and decision making capabilities among students (Jackson & Wilton 2016b). This result is in alignment with Jackson and Wilton (2016b). Their study established a positive association between decision making skills and perceived employability among Australian undergraduates. This finding suggests that universities need to pay attention to activities that will assist students in developing the ability to make informed decisions based on the available opportunities, to take into account the risks involved in decision making, and to learn to take responsibility for decision making (Crişan et al., 2015; Law & Watts, 2003).

Transition learning (also referred to as job search and self-presentation skills) having a positive association with undergraduate's employability, stresses the importance of developing appropriate strategies to make effective transitions from learning to work. Transition learning skills include the ability to demonstrate an understanding of effective opportunity-search strategies; apply understanding of recruitment/selection methods to applications; use relevant vacancy information including ways of accessing unadvertised vacancies; and present oneself effectively in selection interviews and other selection processes (McIlveen et al., 2011:6; Watts, 2006:11). Hillage and Pollard (1998) refer to such skills as the ability to demonstrate employability assets and present them to employers. Reiterating the importance of transition learning skill, Dacre Pool and Sewell (2007) have noted that there is little to be gained in training students if, at the end of the day, they cannot identify a market in which to advertise their developed employability. Therefore, students should be made aware of and be encouraged to engage in activities that will enhance their job search and self-presentation skills (such as CV writing and interview techniques). According to

Jackson and Wilton (2016b), the possession of such skills has the likely potential of boosting confidence in being able to move into the graduate labour market without much effort.

### Recommendations

The results emanating from this study are valuable, where they recommend that universities ought to intensify efforts to develop strategies to engage undergraduates in activities which lead to the development of opportunity awareness, self-awareness, decision making, and transition learning skills as suggested by the DOTS model. Such effort may include the adoption and development of a quality career guidance activities model, which encourages students to actively engage with the different dimensions of the DOTS model.

The respective skills of opportunity awareness and self-awareness have the greatest influence on undergraduates' employability in Nigeria, which suggests that universities should emphasise activities that promote these in their students. Such activities include encouraging students to conduct research into the employment market for their particular profession, or conducting interviews with employers, the use of guest lecturers from different industries, inviting employers to talk about employment opportunities and skills requirements for these opportunities, and students' exposure to work experience at least twice before graduating.

To gain competitive advantage in the labour market, undergraduates need to be aware of the importance of career guidance activities, and need to be encouraged to engage in a broad range of such activities, as identified in this study. This engagement will not only help them in acquiring the skills and confidence necessary to secure graduate jobs, but also assist them in making informed decisions regarding their intended occupational field and specific occupation. This study is limited to the influences of decision making, opportunity awareness, self-awareness and transition learning on students' employability in the South-West, Nigeria. The DOTS model was empirically validated based on sample data at selected universities in a specific geo-political zone. Therefore, future research may consider data collection from all geo-political zones in Nigeria to make a valid generalisation. Further research direction also points to the use of a longitudinal approach to objectively investigate the cause and effect of career guidance activities on graduate employability in Nigeria.

### Conclusion

In this study, a structural examination of students' employability through career guidance activities offered at selected universities in Nigeria was conducted. The study also identified the exogenous variable that performed a superb role in deter-

mining students' employability in Nigeria. Four exogenous variables, which constitute key elements of career guidance activities, were investigated in line with the DOTS model. These exogenous variables are: decision making; opportunity awareness; self-awareness; and transition learning skills. The endogenous variable investigated is students' employability.

Students' opinions were collated quantitatively and analysed using sophisticated multivariate statistical tools i.e., exploratory and confirmatory factor analyses, and structural equation modelling. Results show that the research instruments used were reliable and valid, based on Cronbach's alpha and composite reliability coefficients, and the average variance extracted. The findings in the measurement and structural models are valuable in concluding that all career guidance activities (that is, decision-making, opportunity awareness, self-awareness, and transition learning skills) investigated in this study have a positive influence on students' employability. Results further show that out of these exogenous variables measuring career guidance activities, activities geared towards the development of self-awareness and opportunity awareness skills have a superior influence on students' employability, followed by decision making skills, and then transition learning skills. This study therefore, concludes that opportunity awareness and self-awareness, decision-making, and transition learning skills are all predictors of students' enhanced employability as proposed in the DOTS model. A major inference that can be drawn from the study is that students in Nigeria and by extension, Africa, now recognise the necessity to take responsibility for developing and managing their employability. This notwithstanding, universities need to ensure the adequate provision of career guidance activities as identified in DOTS model for students' enhanced employability and should ensure that students are aware of these opportunities.

#### Acknowledgement

We gratefully acknowledge the support provided by the authorities of the four universities in Nigeria where the samples for the research were drawn. We are also grateful to the following lecturers and researchers: Dr Damilola Adekanmbi of Ladoko Akintola University of Technology, Ogbomosho; Dr Toyin Fashae of University of Ibadan, Ibadan; Dr Marcus Ayoola of Obafemi Awolowo University, Ile-Ife; and Dr John Ajaelu of Bowen University, Iwo, who assisted in the administration of the questionnaire.

#### Note

- i. Published under a Creative Commons Attribution Licence.

#### References

- Adedeji S & Oyebade S 2016. In pursuit of graduate employability and inclusive development in Nigeria: realities and expectations. In British Council. *Universities, employability and inclusive development: Repositioning higher education in Ghana, Kenya, Nigeria and South Africa*. London, England: British Council. Available at <https://ereadiness.kenet.or.ke/sites/default/files/ctools/Graduate%20employability%20final%20report.pdf>. Accessed 29 October 2016.
- Archer E & Chetty Y 2013. Graduate employability: conceptualisation and findings from the University of South Africa. *Progressio*, 35(1):136–167.
- Ariffin HF, Raja-Abdullah RPS, Baba N & Hashim S 2015. Structural relationships between career development learning, work integrated learning and employability: A structural equation modelling approach. In SM Radzi, N Sumarjan, CT Chik, MSM Zahari, Z Mohi, MFS Bakhtiar & FI Anuar (eds). *Theory and practice in hospitality and tourism research*. Leiden, The Netherlands: CRC Press/Balkema.
- Ariffin HF & Saedahtinnur H 2012. The relationship between career development learning, workplace experience and employability among UiTM hospitality graduates. In A Zainal, SM Radzi, R Hashim, CT Chik & R Abu (eds). *Current issues in hospitality and tourism: Research and innovations*. Boca Raton, FL: CRC Press.
- Bennett D, Richardson S & MacKinnon P 2016. *Enacting strategies for graduate employability: How universities can best support students to develop generic skill Part A*. Canberra, ACT: Australian Government, Office for Learning and Teaching, Department of Education and Training. Available at [http://melbourne-cshe.unimelb.edu.au/\\_data/assets/pdf\\_file/0011/1874774/SP13-3258\\_Curtin\\_Bennett\\_Graduate-Employability\\_Final-Report\\_Part-A\\_20163.pdf](http://melbourne-cshe.unimelb.edu.au/_data/assets/pdf_file/0011/1874774/SP13-3258_Curtin_Bennett_Graduate-Employability_Final-Report_Part-A_20163.pdf). Accessed 9 March 2017.
- Bridgstock R 2009. The graduate attributes we've overlooked: enhancing graduate employability through career management skills. *Higher Education Research & Development*, 28(1):31–44. <https://doi.org/10.1080/07294360802444347>
- Byrne BM 2010. *Structural equation modeling with AMOS: Basic concepts, applications, and programming* (2nd ed). New York, NY: Routledge. Available at [http://hbanaszak.mjr.uw.edu.pl/ZlozoneModeleSkalowaniaLiniowego/Literatura/SEM/Byrne\\_2010\\_Structural%20Equation%20Modeling%20with%20AMOS.pdf](http://hbanaszak.mjr.uw.edu.pl/ZlozoneModeleSkalowaniaLiniowego/Literatura/SEM/Byrne_2010_Structural%20Equation%20Modeling%20with%20AMOS.pdf). Accessed 9 July 2017.
- Chillas S, Marks A & Galloway L 2015. Learning to labour: an evaluation of internships and employability in the ICT sector. *New Technology, Work and Employment*, 30(1):1–15. <https://doi.org/10.1111/ntwe.12041>
- Creasy R 2013. Improving students' employability. *Engineering Education*, 8(1):16–30.
- Crişan C, Pavelea A & Ghimbuţ O 2015. A need assessment on students' career guidance. *Procedia - Social and Behavioral Sciences*, 180:1022–1029. <https://doi.org/10.1016/j.sbspro.2015.02.196>

- Dacre Pool L, Qualter P & Sewell PJ 2014. Exploring the factor structure of the CareerEDGE employability development profile. *Education + Training*, 56(4):303–313. <https://doi.org/10.1108/ET-01-2013-0009>
- Dacre Pool L & Sewell P 2007. The key to employability: developing a practical model of graduate employability. *Education + Training*, 49(4):277–289. <https://doi.org/10.1108/00400910710754435>
- Dickinson J & Griffiths TL 2015. Embedding employability and encouraging engagement with PDP/careers: a case study focussing on law students. *Student Engagement and Experience Journal*, 4(1). <https://doi.org/10.7190/seej.v4i1.101>
- Fallows S & Steven C 2000. Building employability skills into the higher education curriculum: a university-wide initiative. *Education + Training*, 42(2):75–83. <https://doi.org/10.1108/00400910010331620>
- Finch DJ, Hamilton LK, Baldwin R & Zehner M 2013. An exploratory study of factors affecting undergraduate employability. *Education + Training*, 55(7):681–704. <https://doi.org/10.1108/ET-07-2012-0077>
- Ghayur K & Churchill DD 2015. *Career success: Navigating the new work environment* (2nd ed). Charlottesville, VA: CFA Institute.
- Guichard J 2001. A century of career education: Review and perspectives. *International Journal for Educational and Vocational Guidance*, 1(3):155–176. <https://doi.org/10.1023/A:1012207018303>
- Harvey L & Contributors 2003. *Transitions from higher education to work*. Available at <https://www.qualityresearchinternational.com/eseectools/eseectpubs/harveytransitions.pdf>. Accessed 9 July 2017.
- Hillage J & Pollard E 1998. Employability: Developing a framework for policy analysis. *Research Brief*, 85. London, England: Department for Education and Employment. Available at <http://webarchive.nationalarchives.gov.uk/20130402091826/https://www.education.gov.uk/publication/s/eOrderingDownload/RB85.pdf>. Accessed 25 November 2016.
- Hooper D, Coughlan J & Mullen M 2008. Structural equation modelling: Guidelines for determining model fit. *Electronic Journal of Business Research Methods*, 6(1):53–60. Available at <http://arrow.dit.ie/cgi/viewcontent.cgi?article=1001&context=buschmanart>. Accessed 6 July 2017.
- Jackson D & Wilton N 2016a. Career choice status among undergraduates and the influence of career management competencies and perceived employability. *Journal of Education and Work*. Advance online publication. <https://doi.org/10.1080/13639080.2016.1255314>
- Jackson D & Wilton N 2016b. Developing career management competencies among undergraduates and the role of work-integrated learning. *Teaching in Higher Education*, 21(3):266–286. <https://doi.org/10.1080/13562517.2015.1136281>
- Kinash S, Crane L & Judd MM 2016. *Good practice report: Nurturing graduate employability in higher education*. Good practice report prepared for the Australian Government Office for Learning and Teaching. Available at <http://epublications.bond.edu.au/tls/136>. Accessed 9 March 2017.
- Knight PT & Yorke M 2003. Employability and good learning in higher education. *Teaching in Higher Education*, 8(1):3–16. <https://doi.org/10.1080/1356251032000052294>
- Law B & Watts AG 2003. *The dots analysis*. Elsworth, England: The Career-Learning Network. Available at <http://www.hihohiho.com/memory/cafdots.pdf>. Accessed 20 October 2016.
- Lowden K, Hall S, Elliot D & Lewin J 2011. *Employers' perceptions of the employability skills of new graduates*. London, England: Edge Foundation. Available at [http://www.educationandemployers.org/wp-content/uploads/2014/06/employability\\_skills\\_as\\_pdf\\_-\\_final\\_online\\_version.pdf](http://www.educationandemployers.org/wp-content/uploads/2014/06/employability_skills_as_pdf_-_final_online_version.pdf). Accessed 10 July 2017.
- Mason G, Williams G & Cranmer S 2009. Employability skills initiatives in higher education: what effects do they have on graduate labour outcomes? *Education Economics*, 17(1):1–30. <https://doi.org/10.1080/09645290802028315>
- McIlveen P, Brooks S, Lichtenberg A, Smith M, Torjul P & Tyler J 2011. Career development learning frameworks for work-integrated learning. In S Billett & A Henderson (eds). *Developing learning professionals: Integrating experiences in university and practice settings*. Dordrecht, The Netherlands: Springer. Available at [https://eprints.usq.edu.au/18512/3/McIlveen\\_Brooks\\_Lichtenberg\\_Smith\\_Torjul\\_Tyler\\_AV.pdf](https://eprints.usq.edu.au/18512/3/McIlveen_Brooks_Lichtenberg_Smith_Torjul_Tyler_AV.pdf). Accessed 15 November 2016.
- Organisation for Economic Co-operation and Development (OECD) 2003. *Education policy analysis*. Paris, France: OECD Publishing.
- Pallant J 2011. *SPSS survival manual: A step by step guide to data analysis using the SPSS program* (4th ed). Perth, Australia: Allen & Unwin.
- Pitan OS 2010. Assessment of skills mismatch among employed university graduates in Nigeria labour market. PhD dissertation. Ibadan, Nigeria: University of Ibadan.
- Pitan OS 2015. An assessment of generic skills demand in five sectors of the Nigerian labor market. *Public and Municipal Finance*, 4(1):28–36. Available at [https://www.researchgate.net/profile/Oluyomibo\\_Pitan/publication/303997520\\_An\\_assessment\\_of\\_generic\\_skills\\_demand\\_in\\_five\\_sectors\\_of\\_the\\_Nigerian\\_labor\\_market/links/57627a1f08ae17685426da58.pdf](https://www.researchgate.net/profile/Oluyomibo_Pitan/publication/303997520_An_assessment_of_generic_skills_demand_in_five_sectors_of_the_Nigerian_labor_market/links/57627a1f08ae17685426da58.pdf). Accessed 6 July 2017.
- Pitan OS 2016a. Employability development opportunities (EDOs) as measures of students' enhanced employability. *Higher Education, Skills and Work-Based Learning*, 6(3):288–304. <https://doi.org/10.1108/HESWBL-05-2016-0024>
- Pitan OS 2016b. Towards enhancing university graduate employability in Nigeria. *Journal of Sociology and Social Anthropology*, 7(1):1–11. Available at [http://krepublishers.com/02-Journals/JSSA/JSSA-07-0-000-16-Web/JSSA-07-1-000-16-Abst-PDF/JSSA-07-1-001-16-218-Pitan-O-S/JSSA-07-1-001-16-218-Pitan-O-S-Tx\[1\].pdf](http://krepublishers.com/02-Journals/JSSA/JSSA-07-0-000-16-Web/JSSA-07-1-000-16-Abst-PDF/JSSA-07-1-001-16-218-Pitan-O-S/JSSA-07-1-001-16-218-Pitan-O-S-Tx[1].pdf). Accessed 5 July 2017.
- Pitan OS & Adedeji SO 2014. Students' choice of courses: Determining factors, sources of information, and relationship with the labour

- market demands in Nigeria. *Africa Education Review*, 11(3):445–458.  
<https://doi.org/10.1080/18146627.2014.934997>
- Prelovský I n.d. *Concept, definition and activities of career guidance and counselling*. Available at [http://www.ies.stuba.sk/erasmus/file.php/1/Documents/CONCEPT\\_definition\\_and\\_activities\\_of\\_CG\\_and\\_counselling.pdf](http://www.ies.stuba.sk/erasmus/file.php/1/Documents/CONCEPT_definition_and_activities_of_CG_and_counselling.pdf). Accessed 17 October 2016.
- Rae D 2007. Connecting enterprise and graduate employability: Challenges to the higher education culture and curriculum? *Education + Training*, 49(8/9):605–619.  
<https://doi.org/10.1108/00400910710834049>
- Savickas ML 2012. Life design: A paradigm for career intervention in the 21st century. *Journal of Counseling & Development*, 90(1):13–19.  
<https://doi.org/10.1111/j.1556-6676.2012.00002.x>
- Savickas ML, Nota L, Rossier J, Dauwalder JP, Duarte ME, Guichard J, Soresi S, Van Esbroeck R & Van Vianen AEM 2009. Life designing: A paradigm for career construction in the 21st century. *Journal of Vocational Behaviour*, 75(3):239–250.  
<https://doi.org/10.1016/j.jvb.2009.04.004>
- Talib JA, Salleh A, Amat S, Ghavifekr S & Ariff AM 2015. Effect of career education module on career development of community college students. *International Journal for Educational and Vocational Guidance*, 15:37–55.  
<https://doi.org/10.1007/s10775-014-9279-x>
- Taylor AR & Hooley T 2014. Evaluating the impact of career management skills module and internship programme within a university business school. *British Journal of Guidance & Counselling*, 42(5):487–499.  
<https://doi.org/10.1080/03069885.2014.918934>
- Tomlinson M 2007. Graduate employability and student attitudes and orientations to the labour market. *Journal of Education and Work*, 20(4):285–304.  
<https://doi.org/10.1080/13639080701650164>
- Walker M & Fongwa S 2016. Universities and employability in South Africa: equity in opportunities and outcomes. In British Council. *Universities, employability and inclusive development: Repositioning higher education in Ghana, Kenya, Nigeria and South Africa*. London, England: British Council. Available at <https://ereadiness.kenet.or.ke/sites/default/files/ctools/Graduate%20employability%20final%20report.pdf>. Accessed 29 October 2016.
- Watts AG 2006. *Career development learning and employability*. York, England: The Higher Education Academy. Available at <https://www.qualityresearchinternational.com/esectools/esectpubs/watts%20career.pdf>. Accessed 15 July 2017.
- Watts AG 2013. Career guidance and orientation. In K Ananiadou (ed). *Revisiting global trends in TVET: Reflections on theory and practice*. Bonn, Germany: UNESCO-UNEVOC International Centre for Technical and Vocational Education and Training. Available at [http://www.unevoc.unesco.org/fileadmin/up/2013\\_epub\\_revisiting\\_global\\_trends\\_in\\_tvete\\_book.pdf](http://www.unevoc.unesco.org/fileadmin/up/2013_epub_revisiting_global_trends_in_tvete_book.pdf). Accessed 16 January 2017.
- Wilton N 2014. Employability is in the eye of the beholder: Employer decision-making in the recruitment of work placement students. *Higher Education, Skills and Work-based Learning*, 4(3):242–255. <https://doi.org/10.1108/HESWBL-07-2014-0027>