

Simultaneous Determination of Metals in Coal with Low-Resolution Continuum Source Atomic Absorption Spectrometer and Filter Furnace Atomizer

Gibson Jim and Dmitri A. Katskov*

Department of Chemistry and Physics, Tshwane University of Technology, Pretoria, 0001, South Africa.

Received 18 October 2010, revised 19 January 2011, accepted 6 February 2011.

Submitted by invitation to celebrate 2011 the 'International Year of Chemistry'.

ABSTRACT

The setup including low-resolution spectrometer with the charge-coupled device (CCD) detector, continuum radiation source and filter furnace (FF) atomizer was employed for direct simultaneous determination of Al, Fe, Mg, Cu and Mn in coal slurry. In the FF, sample vapour entered absorption volume by filtering through heated graphite. Absorption spectrum within 200–400 nm was repeatedly recorded during the atomization period with spectral resolution 0.3 nm. The output of the CCD elements was measured within each spectrum, atomic absorption at specific wavelengths measured and corrected with respect to the linearization algorithm, and integrated. Calibration was performed using carbon slurry impregnated by the analyte metals as well as with the analytes added to the slurries as multi-element solutions. The comparison showed preference of the second method, which provides for 60 % of measurements the results within 10 % deviation range from the certified reference data independent of concentration of the analyte. Low-resolution spectral instrument with fast CCD detection makes possible simultaneous detection of transient absorption signals for several elements. The use of continuum light source makes it possible to determine broad range of concentrations without slurry dilution.

KEYWORDS

Coal slurry, electrothermal atomic absorption spectrometry, simultaneous multi-element determination, filter furnace atomizer.

1. Introduction

The need to analyze coal for major and minor components has been underscored in 1970s and later on in the publications, legislative and normative documents regarding air control, geological and environmental research or quality of industrial products such as coke, iron and steel. Accordingly, increasing sophisticated analytical methods including X-ray/ γ -ray; optical absorption/emission; mass-spectrometry; wet chemical and various electro analytical methods have been applied to characterize content of inorganic components in coal, coal ash, and its derivatives.¹

The standard method, ASTM (American Standards for Testing and Materials International) D6349 is recommended for determination of major and minor elements in coal, coal ash, coke and their solid combustion residues.² To perform analysis, the sample is initially ignited under controlled conditions until a constant mass is obtained. The ash that results is digested in a mixture of acids; the solution is analyzed by inductively coupled plasma atomic emission (ICP AES) that permits characterization of number of elements in a broad concentration range. Although various acids and acid mixtures, including HNO₃, HCl, HF, HClO₄, H₂SO₄, H₃BO₃ and H₂O₂ could be employed for the digestion, the procedure remains lengthy (turnaround time nearly 2 days). The extensive use of acids and fluxing materials cause corrosion of instrument parts and matrix effects.³

Slurry atomization, in which an aqueous suspension of coal is introduced into ICP AES^{4,5} was attempted to avoid the drawbacks associated with ashing and dissolution. In this case

apparent problems arose related to slurry preparation regarding grinding method, optimal sizes of coal particles, preventing their coagulation in the slurry medium as well as problems related to vaporization of solid particles and spectral/chemical interferences. Persistence of the problems associated with direct introduction of slurries in ICP AES gave reason for the development of alternative methodology of coal slurry analysis using electrothermal atomic absorption spectrometry (ET AAS).

It has been verified that the slurry can be diluted and injected in the graphite tube atomizer in a similar way to solution and the analyte losses and/or sample contaminations prevented.^{6–8} Prospects of the method have been highlighted since the introduction of the high-resolution continuum source (HR-CS) ET AAS instrumentation.⁹ The method permits fast sequential determination of several elements with efficient background (BG) correction and limits of detection (LOD) similar or below those in traditional ET AAS with linear radiation sources. However, independent of the type of the instrument, problems associated with chemical interferences, calibration difficulties, weighting errors, sample inhomogeneity, etc., are still characteristic for ET AAS with graphite tube atomizers; determination error depends on the slurry dilution; the problem of simultaneous determination of several elements also remains persistent.^{8–10}

Within the scope of environmental problems those related to the determination of elements normally present in coal as high concentrations (Al, Fe, Mg, Cu, Mn and some other) are of specific interest. Their presence in the air together with combustion products is hazardous for human health.¹¹ Substantial dilution of the slurry in order to reduce sampled mass causes increase of

* To whom correspondence should be addressed. E-mail: katskovda@tut.ac.za

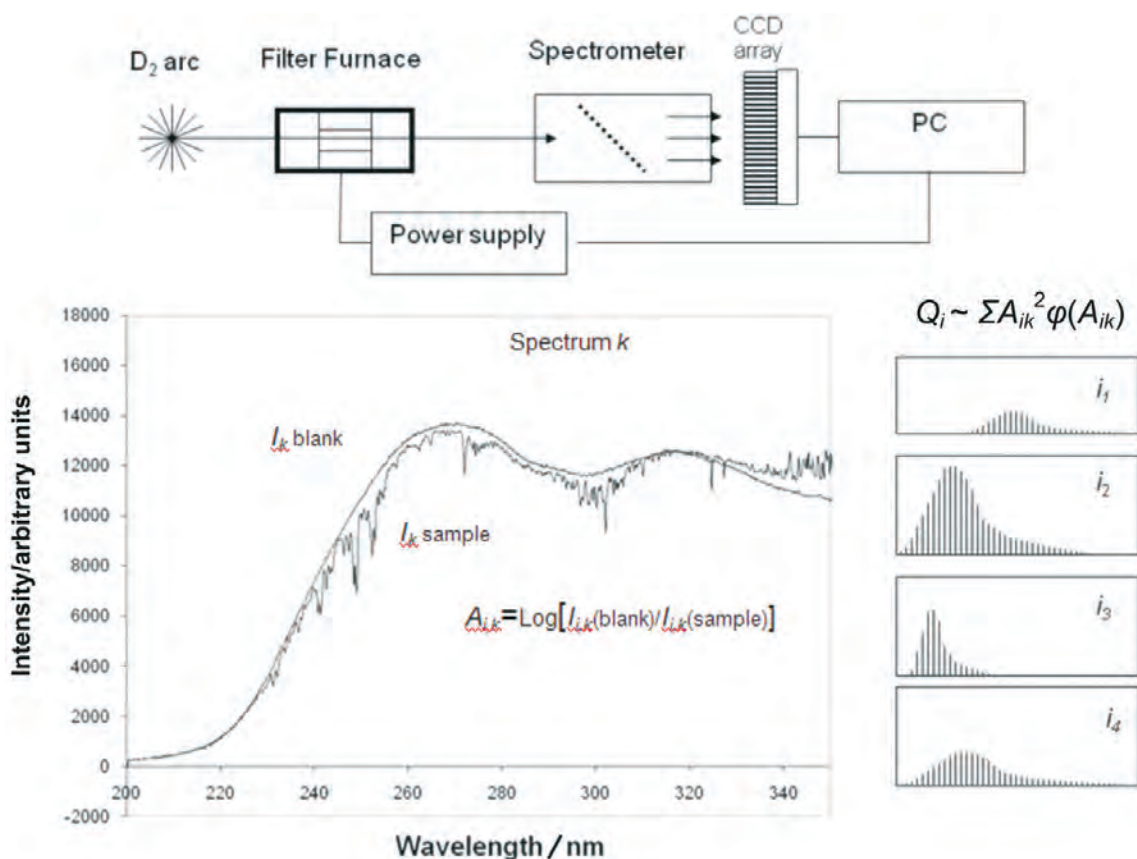

Figure 1 The setup and principle of measurements.

determination error. In contrast, high solids content in the slurry causes interferences and saturation of atomic absorption line. Indeed, the problem can be partially solved within HR-CS ET AAS slurry sampling methodology by using various analytical lines and temperature programs optimized for each element to be determined. However, this way leads to low sample throughput.

This work suggests alternative methodology based on slurry sampling in filter furnace (FF) atomizer¹² and simultaneous multi-element electrothermal (SMET) AAS determination using low-resolution CCD spectrometer coupled with a continuum light source.¹³

The filter furnace atomizer consists of pyrocoated graphite tube (normally of standard configuration employed in the AA spectrometer) and spool shaped graphite insert introduced coaxially in the tube. The ring cavity between the filter and walls of the tube is loosely filled with carbon fibre. The liquid to be analyzed is injected through the dosing hole in the ring cavity and the atomizer exposed to step-wise heating including fast ramp at the atomization stage. The sample vapour enters absorption volume in the central part of the filter through the heated graphite. With the determination of high and medium volatile elements in organic and inorganic liquids, the filter furnace provides: i) 1.5–2 times increase in sensitivity compared to normal platform tube furnace; ii) opportunity to increase sampling volume to 50 μL or more, depending on internal diameter of original tube; and, iii) reduction of spectral interferences caused by organic and inorganic matrix.¹² These characteristics make FF attractive for slurry analysis.

In the SMET AAS instrument¹³ radiation of deuterium or Xe arc lamp within 200–400 nm spectral range is monitored and absorption pulses corresponding to various elements detected using the CCD spectrometer with transmittance profile 50 or more times broader than in HR CS spectrometer⁹. Low-resolu-

tion and radiation continuum provide square root function absorbance *vs.* concentration of atomic vapour for all elements to be determined. The calculation algorithm includes automatic correction of non-linearity and integration of corrected absorption peaks. The methodology¹³ is less sensitive than traditional single element or HR CS ETAAS; LOD (with 20–30 μL sampling) are close to those with flame AAS. On the other hand, it permits instant simultaneous determination of several elements from a single sample within 3–4 order concentration range. Although spectral interferences due to overlap of absorption lines of various elements cannot be ruled out, probability of overlapping is substantially reduced in comparison with ICP AES.

This work investigates the simultaneous AAS determination of inorganic components, normally present in coal within broad concentration range (i.e. Al, Cu Fe, Mg and Mn), in a coal slurry using FF atomizer.

2. Experimental

2.1. Instrumentation

The experimental setup included continuum light source, FF atomizer and Ocean Optics HR4000 spectrometer (with charge coupled device (CCD) detector connected to PC (Fig. 1). A grating of 1200 grooves/mm and spectral slit of 25 μm provided full width at half maximum (FWHM) of the transmittance profile of the spectrometer about 0.3 nm in spectral area 200–420 nm; the instrument was equipped with Toshiba 3680 pixels CCD. Radiation from the deuterium continuum spectrum lamp (Mikropack D2000) was transferred through optical cable (QP450-0.25-XSR) and focused in the centre of the absorption volume by collimating lens (74-UV). Second lens focused radiation on the entrance slit of the spectrometer.

The software (Ocean Optics SpectraSuite) provided monitor-

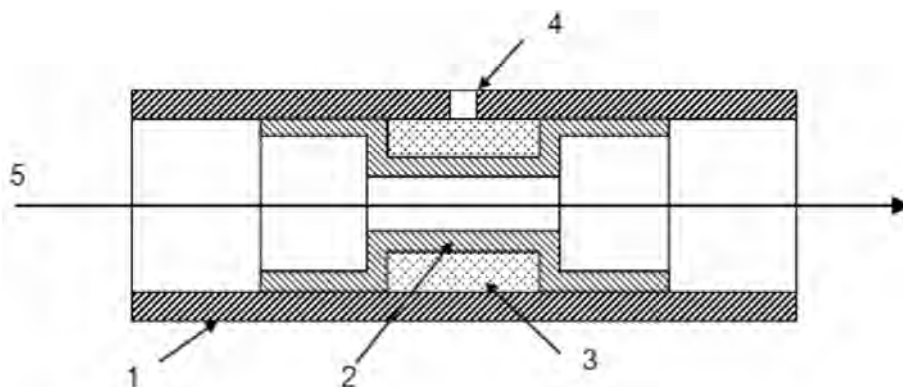

Figure 2 Longitudinally heated filter furnace atomizer. 1, pyrocoated graphite tube; 2, graphite filter; 3, ring cavity (empty for the slurries or filled with carbon fibre for liquid samples); 4, sampling port; 5, light beam.

ing of the spectra with a frequency controlled by data collection time. Low light output at short wavelength area (Fig. 1) did not allow the use of data collection time less than 15 ms.

Filter furnace atomizer (Fig. 2) was built on the basis of atomization unit HGA-500 (Perkin Elmer). Standard pyrocoated tubes Perkin Elmer (BO 091 504) 6 mm in internal diameter) were employed for the accommodation of the inserts made of graphite rods (AGKSP grade, Alfa Aesar, Massachusetts, USA). Central part of the insert formed absorption volume 10 mm and 2 mm in length and diameter, respectively; external surface of the filter together with internal surface of the pyrocoated tube formed a ring cavity in which the sample was to be injected. In the filter furnace for analysis of liquids the cavity was loosely filled with collector, 20 mg of carbon fibre (Alfa Aesar). The collector helped to keep liquid sample within the ring cavity preventing its penetration in the filter at the drying stage. It also provided a delay in the vaporization of the analyte that improved atomization efficiency.¹² For the slurries the tube without fibre was employed.

The HGA-500 power supply provided programmed heating of the atomizer and triggering of data collection. Number of spectra obtained at this stage of research did not exceed 80 because of limitation from the Excel program employed in the calculations.

2.2. Samples and Reference Materials

Standard reference materials SARM 18, Coal (Witbank); SARM 19, Coal (Orange Free State); SARM 20, Coal (Sasolburg), Coal Ash SABS 106, all from South Africa Bureau of Standards (SABS)) were employed in the optimization and validation of analytical procedure. A ground and homogenized coal sample from Witbank Coal Field, South Africa, which had been analyzed previously using a slurry nebulization technique,⁵ was also employed. The certified values of Al, Fe, Mg, Cu and Mn contents in the reference materials are reported in Table 1.

To prepare coal slurry, portions of the solid material was

weighted (about 0.01 to 0.2 g in various experiments), put into the volumetric flasks and water or metal solutions was added to make 5 mL volume. A 20–30 μL aliquot was manually injected in the FF with micropipette immediately after intense shaking of the flask. This injection volume corresponded to about 1×10^{-3} g of solid sample and according to the data in Table 1, the respective amounts of the metals thus introduced in the FF ranged between 10 and 250 μg for Al and 5–20 ng for Cu.

Single element solutions of Al, Fe, Mg, Cu and Mn (SAARCHEM Pty, Ltd, South Africa Spectrascan, Teknolab, Sweden) and their mixtures were employed for wavelength calibration of the CCD elements, diagnosing of possible spectral interferences and calibration of the measurements. The working solutions of individual elements and their mixture were prepared to provide similar concentrations of each analyte from the solutions of both types. The calibration solutions were obtained by sequential dilution of the stock solution from 2 to 64 times.

Calibration measurements were also performed using carbon slurries: 20 mL of the multi-element stock solution was mixed with 10 g of ultra 'F' purity graphite powder (Alfa Aesar) and dried in the oven. The weighted portions (about 0.02 to 0.64 g) of powder impregnated with metals were put into the volumetric flasks to make 5 mL volume.

2.3. Procedure

The samples were injected into the FF and heated stepwise according to the temperature program in Table 2. During the atomization and cleaning stages radiation passing through the vaporizer was repeatedly monitored, and the generated data from 80 acquisitions captured by the computer.

The program in Table 2 was chosen according to the following considerations: i) the drying of the solutions and slurries in the ring cavity of tube with and without carbon fibre collector should be performed fast using temperature above the boiling point of the injected liquid to prevent premature penetration of the analytes in the filter; ii) the pyrolysis and the atomization

Table 1 Certified content of major inorganic components in the reference materials

Analyte	Content/% mass				
	Coal SARM 18	Coal SARM 19	Coal SARM 20	Coal ash SABS 106	Coal RM *
Al [Al ₂ O ₃]	1.36 [2.57 \pm 0.04]	4.24 [8.01 \pm 0.15]	5.96 [11.27 \pm 0.46]	13.0 [24.5 \pm 1.41]	4.65 [8.8 \pm 0.1]
Fe [Fe ₂ O ₃]	0.2 [0.29 \pm 0.01]	1.23 [1.75 \pm 0.02]	0.82 [1.17 \pm 0.02]	2.71 [3.87 \pm 0.2]	0.63 [0.9 \pm 0.1]
Mg [MgO]	0.066 [0.11 \pm 0.01]	0.12 [0.2 \pm 0.02]	0.26 [0.43 \pm 0.02]	0.88 [1.46 \pm 0.06]	0.30 [0.5 \pm 0.1]
Cu	(5.9 \pm 0.7) $\times 10^{-4}$	(13 \pm 2) $\times 10^{-4}$	(18 \pm 3) $\times 10^{-4}$		
Mn	(22 \pm 1) $\times 10^{-4}$	(157 \pm 14) $\times 10^{-4}$	(80 \pm 3) $\times 10^{-4}$		136 $\times 10^{-4}$

* Coal sample analyzed using slurry nebulization ICP-AES technique and referred to in⁵ as 'seam 2 coal'.

Table 2 Thermal programme employed for multi-element analysis with filter furnace.

Step	Temperature */°C	Ramp/s	Hold/s	Gas/mL min ⁻¹
Drying	120–140	1	5	50
Pyrolysis	200–600	1	30	300
Atomization	2400	1 *	9 *	0
Cleaning	2450	1 *	3 *+2	300

* The indicated temperatures correspond to the program settings. According to previous work¹⁴, the temperature of the filter and of the gas in the absorption volume can be by 200–300 °C higher than the programme settings.

** Spectra acquisition.

steps supposedly guarantee maximal removal of background without losses of volatile elements and high degree of atomization, respectively. As such, temperatures of 600 °C and 2400 °C with high gas flow rate for the pyrolysis step and gas stop mode for the atomization step, respectively, were selected. Nominal heating ramp time 1 s provided increase and stabilization of the FF temperature within 5–6 s. Argon flow through the furnace and temperature 2450 °C were employed at the cleaning step.

The acquisition of 80 spectra was performed during 14 s including 1 s ramp, 9 s hold and 4 s cleaning time. The heating programme was run for blank measurement and then repeated for the sample (Fig. 1). Absorbance A_{ik} was calculated using output current for each CCD element (i) in each spectrum (k), for the blank and sample measurements

$$A_{ik} = \text{Log}[I_{ik}(\text{blank})/I_{ik}(\text{sample})]. \quad (1)$$

The data from the CCD elements, corresponding to the analytical lines of the metals to be determined were automatically extracted; each A_{ik} value squared to provide proportionality to concentration of atomic vapour in the absorption volume, and summation of 80 data sets performed¹³,

$$Q_i = \theta \times \sum_{k=0}^{\uparrow} (k=80) \equiv A_i (ik) \uparrow 2 \times \varphi(A_i ik), \quad (2)$$

where θ is time of acquisition of individual spectrum, and φ is Excel function equal to -1 or $+1$ according to the sign of the argument. Since the acquisition time was similar in all experiments, integrated squared absorbance Q_i in the text is expressed in arbitrary units.

3. Results and Discussion

3.1. Multi-element Analysis of the Solutions

The experiments with solutions were aimed to evaluate opportunities of simultaneous AA determination of large amounts of Al, Fe, Mg, together with minor amounts of Cu and Mn in the longitudinally heated filter furnace. The spectra and absorption signals for the solutions of individual elements and their mixtures were compared within broad concentration range. At this stage of experiments a carbon fibre collector was employed in the FF to provide a substrate over which the dry residue of the analytes was to be distributed.

The spectral distribution of integrated squared absorbance Q_i vs. wavelength is shown in Fig. 3 for individual elements and their mixture for equal concentrations. In the spectra of all elements except Al only atomic lines were present. For Al broad molecular band in the area 230–270 nm overlapped the atomic lines. The band can be attributed to molecule Al_2O ¹⁵, most probably formed by Al atoms in the colder area near the tube ends. The Figure shows that the most sensitive absorption lines of Al, Fe, Mg, Cu and Mn within 280–350 nm spectral area do not overlap and, hence, can be used for simultaneous determination of these elements notwithstanding the possibility of spectral interferences from other elements present in the coal.

The absorption signals for the elements injected in the FF as multi-element solution are reported in Fig. 4. The signals have a 'tailing', most probably due to non uniform temperature distribution along the longitudinally heated tube.¹⁴ The signals obtained from the solutions of individual elements are similar to

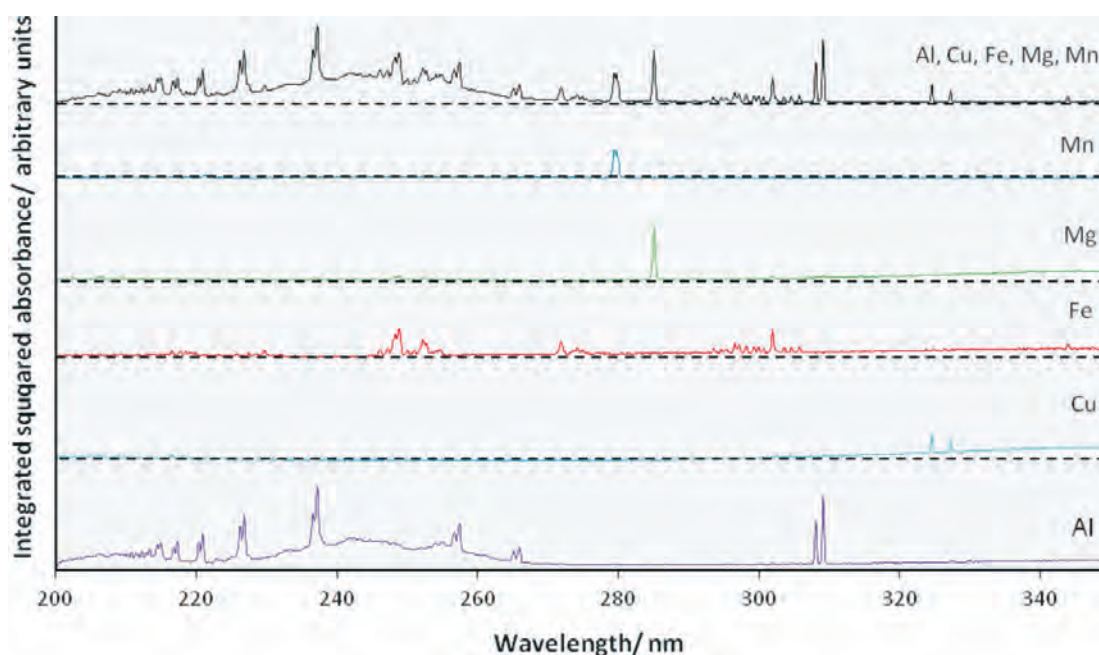

Figure 3 Absorption spectra of individual elements and their mixture introduced in filter furnace as 30 μL of solutions, 37 (Al), 0.9 (Cu), 7.5 (Fe), 3.1 (Mg), and 3.2 (Mn) mg/L.

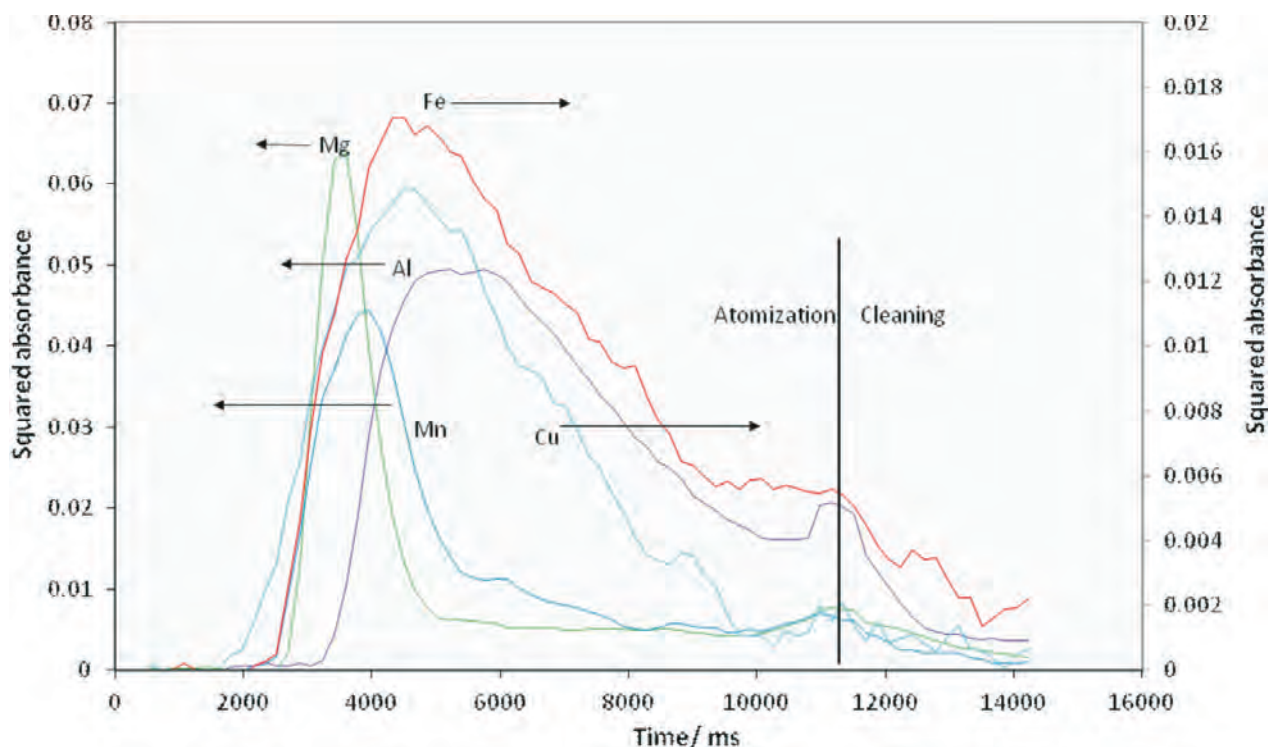

Figure 4 Atomic absorption signals for 1.125 μg Al, 0.027 μg Cu, 0.225 μg Fe, 0.096 μg Mn and 0.093 μg Mg sampled as 30 μL of the mixed solution in the FF furnished with 20 mg carbon fibre collector. Arrows indicate the axis to which the signals are attributed.

those in Fig. 4 for Mg and Mn and slightly faster for Al, Cu and Fe.

The calibration curves Q_i vs. sampled mass, m (μg) for the single element and mixed solutions in Log-Log coordinates (Fig. 5) are approximated by linear regressions (Table 3) with correlation coefficients close to 0.99 for Cu, Mg and Mn and 0.97 for Al and Fe. In total, concentration range of the measurements extends over 3 orders of magnitude. The slopes of respective calibration curves vary within the range 0.87–0.99 for single solu-

tions and 0.81–0.93 for multi-element solutions. Similar deviation of the slope from the theoretically predicted value, unity, had been observed earlier for the tube furnace¹³ that was attributed to incomplete atomization. Possibly, some deviations could be also associated with incomplete integration of the signals due to the 'tailing' (Fig. 4). Difference between the slopes of the curves for particular analytes in the single and multi-element solutions is not significant and can hardly be attributed to spectral interferences.

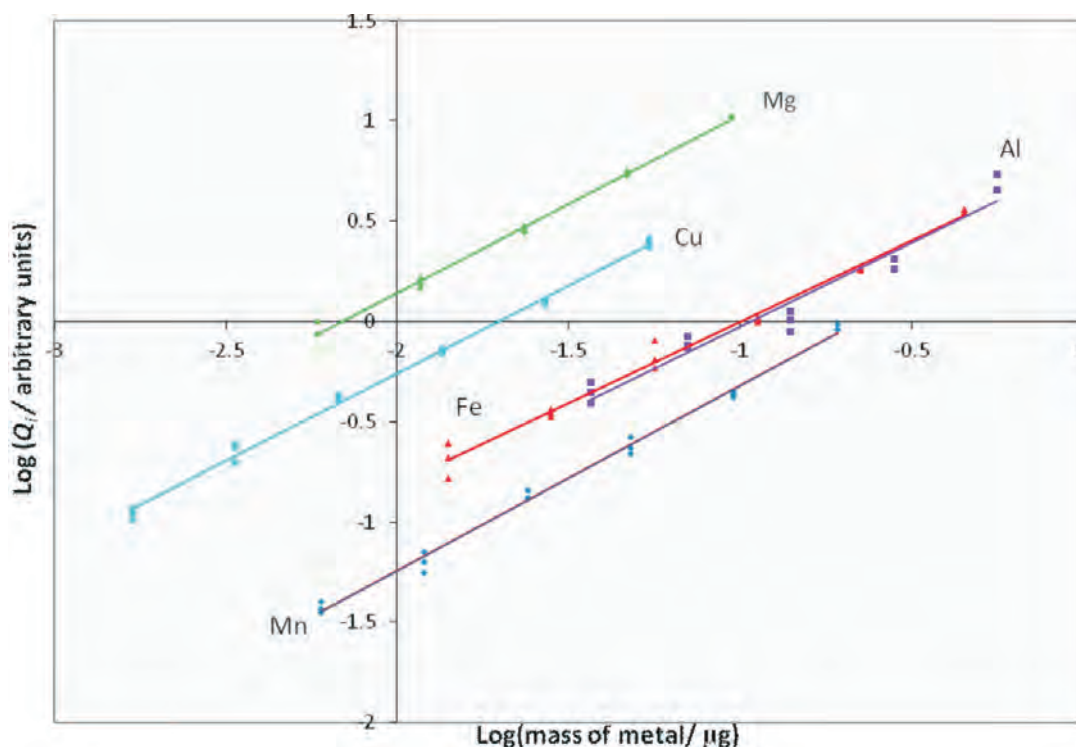

Figure 5 Calibration curves for the metals in the multi-element solutions.

Table 3 Calibration functions for the solutions and carbon slurries.

Element Wavelength/nm	Range of sampled masses/ μg	Calibration curve $\text{Log } Q_i^{*1} = a \times (\text{Log } m, \mu\text{g}) + b$					
		FF with a collector ^{*2}				FF without collector	
		Individual solutions		Mixed solutions		Impregnated carbon	
		<i>a</i>	<i>b</i>	<i>a</i>	<i>b</i>	<i>a</i>	<i>b</i>
Al 309.27	4.5–0.14	0.99	0.66	0.93	0.59	0.96	0.46
Cu 327.75	0.108–0.0034	0.92	1.33	0.87	1.23	0.88	0.95
Fe 302.064	0.9–0.028	0.97	0.57	0.81	0.56	0.94	0.19
Mg 285.21	0.19–0.012	0.87	1.69	0.91	1.68	0.88	1.5
Mn 279.48	0.384–0.012	0.95	0.38	0.90	0.31	0.78	0.06

*1Arbitrary units.

*220 mg carbon fibre.

*3Sampling 0.059–1.920 mg carbon powder impregnated with metals: 0.12 (Al), 0.025 (Fe), 0.01 (Mg), 0.003 (Cu) and 0.01 (Mn) mass %, as 30 μL slurry.

It was reported previously that the ‘tailing’ caused by non uniform temperature distribution can be reduced for the longitudinally heated FF of special design¹⁴ or for transversally heated FF¹². For the FF employed in this work, Fig. 2, the ‘tailing’ can be reduced by increase of atomization and cleaning temperature above the values indicated in Table 2, or by removal of carbon fibre collector.

3.2. Sampling of Carbon Slurries

If the sample to be analyzed is introduced in the filter furnace as slurry, the analyte from solid particles cannot penetrate in the body of the filter before the atomization stage; faster vapour release is expected from the FF without a collector. For this reason, the analyses involving slurries were performed without the carbon fibre collector.

Considering slurry injection, it should, however, be taken into account that multiple sampling can cause storage of refractory ash or pyrolysis products in the ring cavity of the FF. Thus, the volume of the FF ring cavity should provide large enough space for the storage of sample residues from a number of slurry injections; as such increasing mass of the stored residue should not slow down vapour release.

In the experiments, the removal of carbon fibre collector, indeed, increased free space in the FF ring cavity. Without a collector, the FF could be easily dismantled, solid materials residues brushed off and FF re-assembled. The effect of the stored residue was investigated by the measurements with repeatable sampling of carbon slurry impregnated with the elements to be determined. In those experiments single 30 μL slurry injection delivered in the FF ring cavity 0.48 mg of carbon powder together with 0.58 μg Al, 0.12 μg Fe, 0.048 μg Mg, 0.014 μg Cu and 0.049 μg Mn. The resulting absorption signals were measured and relative standard deviation (RSD) of integrated absorbance in 10 sequential measurements calculated. The RSD values found were 6 % (Al); 8 % (Fe); 4 % (Mg); 3 % (Cu) and 7 % (Mn). The storage of about 5 mg of carbon powder in the FF in 10 measurements did not cause any tangible deviation of the analytical signals from the average values.

At the next stage of experiment, the effect of slurry sampling on the determination sensitivity was investigated: various masses of carbon powder impregnated with metals were injected as slurries in the FF without a collector and respective calibration curves plotted. The Log–Log calibration curves were approximated by linear regressions (Table 3) with correlation coefficient above 0.99 for Cu, Mg and Mn; and about 0.95 for Al and Fe. For all elements the sensitivities were reduced from two to four times in comparison with the FF furnished with carbon fibre collector (see, coefficients *b* in Table 3). Apparent reason of the

sensitivity reduction was redistribution of vapour flows through the sampling hole and filter: Without a collector, vapour losses through the sampling hole increased. There was no statistically significant difference between the calibration curves obtained with 15 and 30 μL aliquots that showed that distribution of carbon particles in the ring cavity did not affect the results. The linearity of the Log–Log calibration curves suggests possibility of using carbon powder impregnated with metals for calibration.

3.3. Coal Absorption Spectrum

The transient absorption spectra from 0.4 mg SARM 18 coal sampled as 30 μL slurry after pyrolysis at 500 and 600 °C is shown in Fig. 6a and Fig. 6b, respectively. The Figure shows that after the pyrolysis at about 600–700 °C the background continuum disappears; increase of temperature is accompanied by the occurrence of various partially temporary resolved molecular bands between 220 and 260 nm, possibly associated with NO, CN, NS or SO₂ species,¹⁵ and atomic lines overlapped between 250 and 280 nm by the band of Al sub-oxide Al₂O₃¹⁶.

The 3-D diagrams for other coal samples show difference from that in Fig. 6 only in the intensity of various molecular bands and atomic lines. For all coal samples investigated, at the temperatures of metal vapor release, only molecular band of Al sub-oxide remained persistent. The selected spectra for the SARM 18 coal slurry (Fig. 7) show that the area between 280 and 350 nm is almost free of background absorption and, hence, can be most efficiently used for the element determination.

3.4. Method Validation

To verify consistency of the methodology of coal slurry preparation and sampling, the slurry containing various masses (*M*) of coal (SARM 18) were injected in the FF and atomic absorption signals for Al, Cu, Fe, Mg and Mn measured in three replicates. The resulting functions $\text{Log } Q_i$ vs. $\text{Log } M$ (Table 4) are approxi-

Table 4 Dependence of absorption peak area on mass of the injected solid fraction for SARM 18 coal slurry

Element	$\text{Log } Q_i = A \times (\text{Log } M \text{ */mg}) + B$		
	<i>A</i>	<i>B</i>	<i>R</i> ²
Al	1.02	1.6	0.97
Cu	1.01	1.2	0.95
Fe	0.87	0.29	0.99
Mg	0.89	1.55	0.99
Mn	0.96	1.46	0.98

* Within 0.07–1.07 mg mass range.

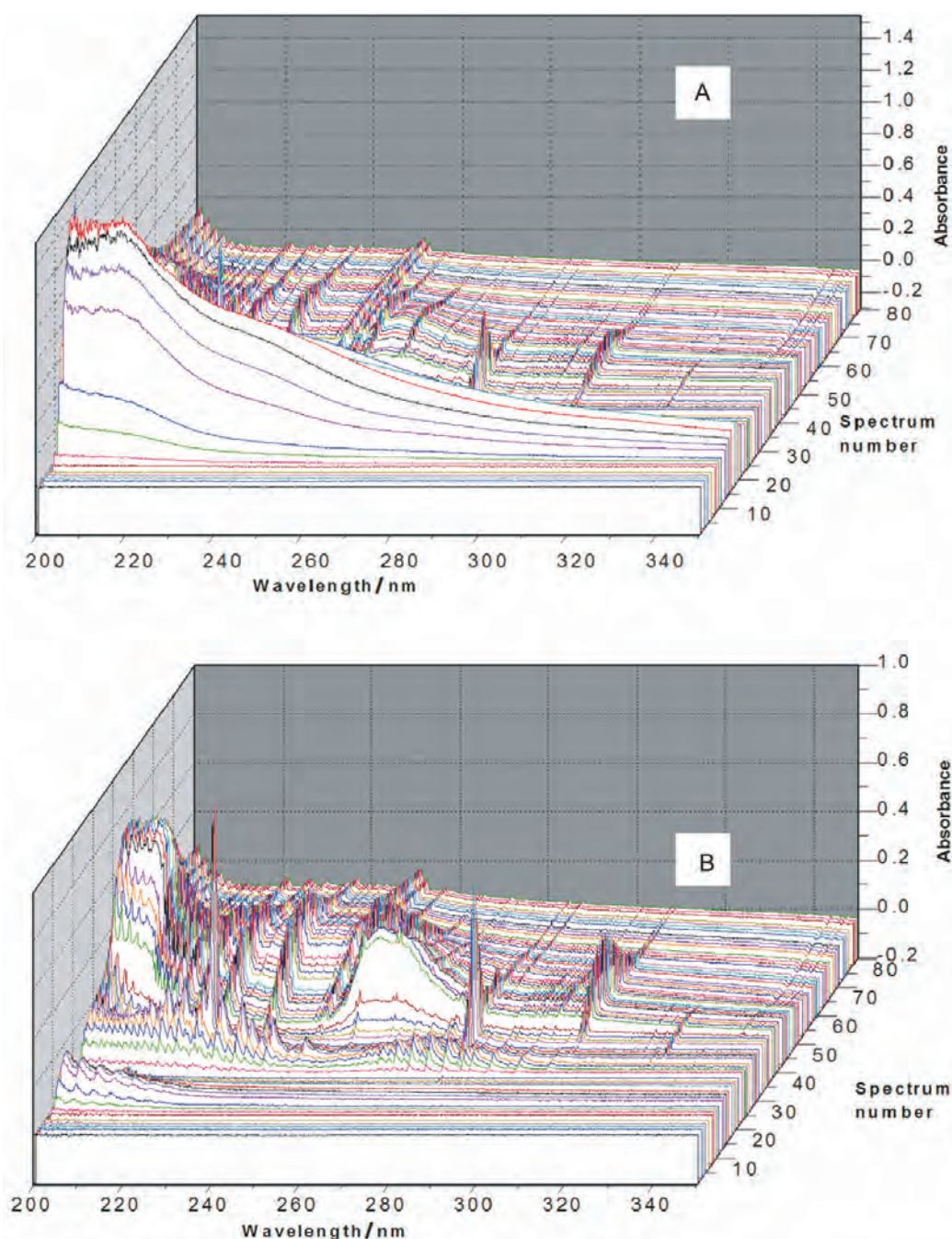

Figure 6 Spectra of 0.4 mg SARM 18 coal slurry in filter furnace after pyrolysis at 500 °C and 600 °C, A and B, respectively.

mated by linear regression $\text{Log } Q_i = A \times \text{Log}M + B$; the coefficients A are close to the a values for the carbon slurry from Table 3. These results show that the suggested methodology provides quantitative injection and measurement of inorganic components in coal.

The preliminary investigation showed a possibility of direct calculation of metal content in coal and coal ash slurry using the calibration curves for carbon slurry (last column of Table 3). This option is implemented in Table 5, where the experimental data from three replicates for each type of sample are presented and calculation results are compared with the reference data. Since of all elements concentration of Al in the RM coal samples was expected to be the highest, masses of solid in the slurries were chosen in such a way to restrict Al absorption on the level below that for Al in SARM 18. It can be seen from the table that for each element integrated absorbance, Q_i is reproducible: random

error as % RSD remains below 10 % and 20 % for the high and low contents of the analytes, respectively, which differ by 3–4 orders of magnitude. However, the results substantially deviate from the respective certified values, by ± 50 % range independent of concentration of particular analyte; in some cases the difference reaches 80–100 %.

Between the factors, which could cause calibration errors, presence of various amounts of organic and inorganic components in the coals and coal ash slurries is the most evident. Pyrolysis of organics in pores of graphite filter as well as interaction of carbon with sulphur or gases released from the sample can affect permeability of the filter for atomic vapour. The redistribution of vapour flows through the filter and injection hole could cause changes in the sensitivity. Apparently, for each particular type of coal specific balance of vapour flows is to be established; therefore, calibration of atomic absorption signals using the analyte

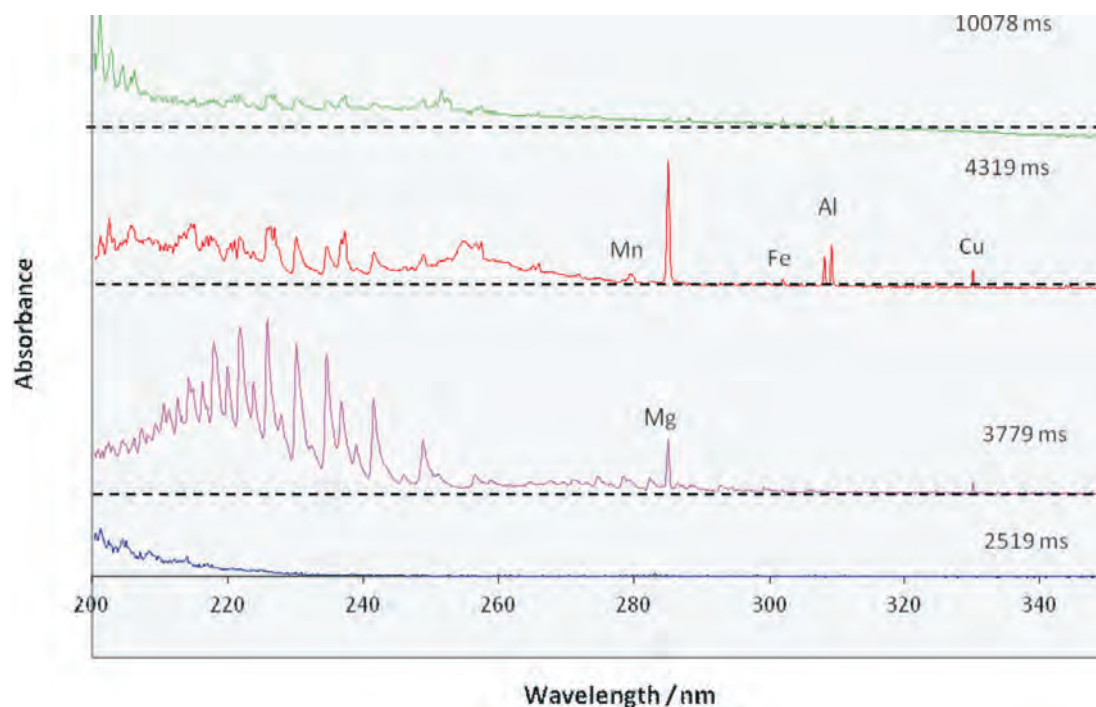

Figure 7 Selected absorption spectra of 0.4 mg SARM 18 coal injected as slurry in filter furnace and pyrolysed at 600 °C.

addition should provide better option than the use of carbon slurry or any other reference material.

In the analyte addition experiments coal slurries were prepared using the multi-element solutions with 3–4 various concentrations of the elements, but within an order of magnitude close to those expected according to Table 4; 30 μ L of slurries in water and multi element solutions were injected in the FF. The results were

calculated from three injection replicates. Linear regression calibration curves with correlation coefficients 0.97–0.99 were obtained for each element in each particular coal sample.

The equations corresponding to the calibration trend lines and respective calculation results are shown in Table 6. Although determination sensitivity (the slope of the calibration curve) differs for any particular element in various samples, the final

Table 5 Simultaneous determination of metals in coals and coal ash with calibration using carbon slurry.

Sample	Mass/mg	Metal	Integrated absorbance, $Q_{i,s}$ * ¹					Metal content	
			Replicate injection			Average	RSD/%	Determined/%	Deviation * ² /%
			1	2	3				
Coal SARM 18	0.6	Al	28.8	30.63	28.59	29.34	3.8	1.8	+34
		Fe	1.30	1.31	1.43	1.34	5.3	0.14	-30
		Mg	20.38	20.06	20.16	20.2	0.8	0.1	+50
		Cu	0.093	0.097	0.109	0.1	8.3	$10.2 \cdot 10^{-4}$	+70
		Mn	0.026	0.023	0.029	0.026	11	$13.2 \cdot 10^{-4}$	-40
Coal SARM 19	0.15	Al	22.69	21.86	19.05	21.2	8.9	5.2	+24
		Fe	1.61	1.34	1.36	1.44	10	0.62	-50
		Mg	4.71	4.09	4.94	4.58	9.5	0.075	-38
		Cu	0.036	0.033	0.024	0.031	20	$10.5 \cdot 10^{-4}$	-20
		Mn	0.023	0.031	0.030	0.028	16	$5.8 \cdot 10^{-3}$	-64
Coal SARM 20	0.105	Al	20.5	15.96	16.04	17.4	15	5.4	-8
		Fe	0.72	0.89	0.72	0.78	13	0.46	-44
		Mg	7.04	5.42	4.92	5.78	19	0.14	-47
		Cu	0.013	0.023	0.014	0.017	33	$7.7 \cdot 10^{-4}$	-57
		Mn	0.008	0.009	0.006	0.0073	23	$147 \cdot 10^{-4}$	+83
Coal ash SABC 106	0.048	Al	35.8	34.6	34.8	35.1	1.8	28	+101
		Fe	1.78	1.73	1.69	1.73	2.6	2.3	-15
		Mg	17.58	18.35	18.46	18.13	2.6	1.1	+20
Coal RM	0.135	Al	20.21	20.32	20.84	20.46	1.6	5.5	+18
		Fe	0.68	0.63	0.58	0.63	7.9	0.3	-52
		Mg	13.6	13.32	12.82	13.24	3.0	0.37	+23
		Mn	0.034	0.031	0.028	0.031	9.6	$7.4 \cdot 10^{-3}$	-45

*¹ Arbitrary units

*² From the values in Table 1.

Table 6 Simultaneous determinations of metals in coal and coal ash slurries using the addition of the analytes as multi-element solutions.

Sample	Mass/mg	Element	Calibration curve $Q_i = cm^{*1} + d$			Determined		Deviation ^{*2} /%
			$c/\mu\text{g}^{-1}$	d	R^2	Mass/ μg	Content /%	
Coal SARM 18	0.6	Al	4.13	31.6	0.983	7.65	1.28	-6
		Fe	1.29	1.57	0.966	1.21	0.202	+1
		Mg	65.74	23.2	0.989	0.35	0.059	-11
		Cu	26.87	0.11	0.981	0.0041	0.00068	+13
		Mn	1.92	0.023	0.999	0.012	0.002	-10
Coal SARM 19	0.15	Al	3.55	20.11	0.987	5.66	3.78	-11
		Fe	1.19	1.36	0.982	1.14	0.76	-38
		Mg	26.42	5.26	0.989	0.2	0.13	+8
		Cu	22.23	0.038	0.994	0.0017	0.0011	-15
		Mn	1.29	0.033	0.997	0.026	0.017	+8
Coal SARM 20	0.105	Al	2.63	16.19	0.995	6.15	5.86	-2
		Fe	1.0	0.89	0.994	0.89	0.84	+2
		Mg	21.12	7.2	0.999	0.34	0.32	+23
		Cu	13.63	0.026	0.996	0.0019	0.0018	0
		Mn	0.92	0.01	0.995	0.01	0.0103	+28
Coal ash SABC 106	0.048	Al	5.28	36.84	0.976	6.97	14.5	-10
		Fe	1.12	2.09	0.97	0.38	2.07	-22
		Mg	46.06	20.9	0.975	0.45	0.94	+7
Coal RM	0.135	Al	4.31	19.47	0.998	4.51	3.3	-30
		Fe	0.85	0.62	0.993	0.72	0.54	-15
		Mg	37.86	14.52	0.99	0.38	0.28	+7
		Mn	1.8	0.027	0.999	0.015	0.011	-20

*1 m (μg), is mass of the analyte added.

*2 From the values in Table 1.

determination results show good correlation with the reference data: Most part of the results (60 %) remains within 10 % range of deviation from the certified values independent of concentration. The highest deviation from the certified content is 38 %. For the sample previously analyzed using slurry nebulization ICP-OES technique⁵, the results are close within 30 %.

4. Conclusion

The suggested method permits simultaneous AA determination of several elements in coal within 3–4 orders of magnitude mass concentration range using relatively simple spectral instrumentation and basic sample preparation. The advantages of the method result from several issues: Low number of atomic absorption lines (*vs.* emission lines in AES) makes possible to employ low-resolution spectral instrument and, respectively, fast CCD detection for simultaneous monitoring of transient absorption signals of several elements. The use of continuum light source permits direct determination within broad concentration range. The calculation algorithm provides linearization of function absorbance *vs.* concentration of the analyte vapour in the absorption volume and integration of respective signals. Slurry sampling and vaporization in the filter furnace guarantees suppression of interferences from organic constituents of coal and independence of measurements from the size of solid particles. The list of lines to be used for the determination can be enlarged.

Acknowledgements

The authors express their gratitude to National Research Foundation of South Africa and Tshwane University of Technol-

ogy for the financial support of the research; and to Prof. Tittarelli for the advises rendered.

References

- 1 F.E. Huggins, *Int. J. Coal Geol.*, 2002, 50, 169–214.
- 2 www.astm.org/Standards/D6349.htm (accessed 1 October 2010).
- 3 I. Rodushkin, M.D. Axelsson and E. Burman, *Talanta*, 2000, 51, 743–759.
- 4 L. Ebdon and J.R. Wilkinson, *J. Anal. At. Spectrom.*, 1987, 2 325–328.
- 5 M. Mujuru, R.I. McCrindle, B.M. Botha, P.P. Ndibewu, *Fuel*, 2009, 88, 719–724.
- 6 B. Welz, M.G.R. Vale, M.M. Silva, H. Becker-Ross, M. Huang, S. Florek and U. Heitmann, *Spectrochim. Acta part B*, 2002, 57, 1043–1055.
- 7 M.G.R. Vale, N. Oleszczuk and W.N.L. dos Santos, *Appl. Spectros. Rev.*, 2006, 41, 377–400.
- 8 M.M. Silva, M.G.R. Vale and E.B. Caramo, *Talanta*, 1999, 50, 1035–1043.
- 9 B. Welz, H. Becker-Ross, S. Florek and U. Heitmann, *High-Resolution Continuum Source AAS: the Better Way to do Atomic Absorption Spectrometry*, Wiley-VCH, Weinheim, 2005.
- 10 C. Bendicho and M.T.C. Loos-Vollebregt, *J. Anal. At. Spectrom.* 1991, 6, 353–374.
- 11 <http://lenntech.com> (accessed 1 October 2010).
- 12 D.A. Katskov, *Spectrochim. Acta Part B*, 2007, 62, 897–917.
- 13 D.A. Katskov and G.E. Khanye, *S. Afr. J. Chem.*, 2010, 63, 45–57.
- 14 D.A. Katskov, P.J.J.G. Marais, V.J. Katkovnik and P. Tittarelli, *Spectrochim. Acta Part B*, 1997, 52, 1377–1394.
- 15 R.W.B. Pearse and A.G. Gaydon, *The Identification of Molecular Spectra*, Chapman & Hall, London, 1950 & 1976.
- 16 D.A. Katskov, A.M. Shtepan, I.L. Grinshtein and A.A. Pupyshev, *Spectrochim Acta Part B*, 1992, 47, 1023–1041.