

# Detection of Sarin with a Fluorinated Polymer-coated Quartz Crystal Microbalance Sensor

Boli Zuo, Wei Li,\* Tian Zhang, Hongxing Zhang and Guohong Liu

*Analytical Center, Institute of Chemical Defense, Beijing, 102205, People's Republic of China.*

Received 8 August 2006, revised 7 September 2007, accepted 23 October 2007.

## ABSTRACT

A quartz crystal microbalance (QCM) modified with a thin layer of fluorinated polymer was utilized to determine sarin. Determination was based on the frequency shifts due to the adsorption and desorption of the compound at the surface of a modified quartz crystal electrode. Fluorosiloxane was synthesized and deposited onto the surface of the sensor. The frequency shifts were linearly dependent on the concentration of sarin within the concentration range of 0.42 ppm to 3.85 ppm. Good selectivity and sensitivity for sarin were obtained with the sensor. The detection limit was 0.15 ppm.

## KEYWORDS

QCM sensor, fluorinated polymer.

## 1. Introduction

Owing to its inherent ability to monitor analytes in real time, the quartz crystal microbalance (QCM) sensor has been applied in environmental monitoring, chemical control, and clinical analysis, etc.<sup>1,2</sup> QCMs are thin quartz crystals sandwiched between two electrodes. An alternating electric field is developed in the quartz by applying a potential difference between the electrodes. The applied voltage produces a standing shear wave across the bulk of the quartz at a characteristic vibrational frequency. The frequency of the QCM vibration depends on the physical properties of the QCM itself. Of particular importance for analytical sensing devices is the proportional relationship between the resonant frequency and the overall mass of the QCM. The relation between the mass change caused by absorbed/desorbed gas molecules on the QCM and the change of the resonant frequency of the QCM follows the Sauerbrey equation,<sup>3</sup>

$$\Delta F = -2.26 \times 10^{-6} f^2 \frac{\Delta m}{A}, \quad (1)$$

where  $\Delta F$  is the measured frequency shift,  $f$  is the original oscillation frequency of the crystal,  $\Delta m$  is the mass change and  $A$  is the piezoelectric active area of the excitation electrodes.

For chemical sensing, coating material has played an increasingly important role in its selectivity and affinity toward the target compounds.<sup>4–6</sup> The coating material should have a high affinity toward the target compounds. In our particular case, sarin, a chemical warfare agent, is an interesting target for its toxic properties for people and the environment.

The conventional methods for detecting sarin involve gas chromatography–mass spectrometry (GC–MS)<sup>7</sup> and gas chromatography with flame photometric detection (GC–FPD).<sup>8</sup> Although there is a precision, high sensitivity and selectivity in analysis, it is well known that the disadvantage of the conventional detection methods, such as chromatographic detection, is that the methods are too slow to detect gas samples *in situ* and this affects the timeliness of the analysis. Furthermore, the chromatographic methods need large instruments for analysis. Now, more and more attention has been focused on research into rapid test methods for sarin. In recent years, a fluorinated polymer-coated sensor has been identified to be efficient for

organophosphorus compounds, especially dimethylmethyl phosphonate (DMMP) and sarin.<sup>9–13</sup> The detection limit for sarin was 0.5 ppm.<sup>11</sup> The polymers exhibit a high thermal stability and low glass transition temperature, which is an interesting property for the sorption and diffusion of the molecules.

In this study, a fluorosiloxane polymer was synthesized and used as a coating material for detecting sarin. The polymer was synthesized in three steps from 4,4'-(hexafluoroisopropylidene) diphenol (HFBA). First, HFBA was reacted with allyl bromide. Then, the ether produced was rearranged by Claisen rearrangement. After the rearranged product was reacted with 1,1,3,3,5,5-hexamethyltrisiloxane using a catalyst of Pt(0)-1,3-divinyl-1,1,3,3-tetramethyl disiloxane (Pt/DVTMS), the fluorinated polymer was obtained. The synthesized polymer with the new end capping functional groups showed good sensitivity and selectivity compared with the polymer of reference 12. The detection limit for sarin of the sensor coated with the synthesized fluorosiloxane was 0.15 ppm.

## 2. Experimental

### 2.1. Materials

4,4'-(hexafluoroisopropylidene) diphenol (HFBA, **1**, 97%), 1,1,3,3,5,5-hexamethyl trisiloxane (97%), and allyl bromide (97%) were purchased from Acros Co. (Geel, Belgium). Pt(0)-1,3-divinyl-1,1,3,3-tetramethyldisiloxane (Pt/DVTMS, 3% xylene solution) was purchased from Aldrich Co. (St. Louis, USA). Tetramethyl ammonium bromide (AR), toluene (AR), absolute ether (AR), glycol (AR), N,N-diethyl aniline (AR), sodium hydroxide (AR) and activated carbon (100–200 mesh) were purchased from Beijing Chemical Reagent Co. (Beijing, China). Sarin (95%) was obtained from the Institute of Chemical Defense (Beijing, China).

### 2.2. Instrumental

Quartz wafer (10 MHz, silver electrode) was purchased from Beijing 707 Factory (Beijing, China). Agilent 53131A Counter (225 MHz) was purchased from Agilent Co. (California, USA). Mass flow controller (MFC, 30–300 mL min<sup>-1</sup>) was purchased from Shengye Co. (Beijing, China).

\* To whom correspondence should be addressed. E-mail: weilliee001@hotmail.com

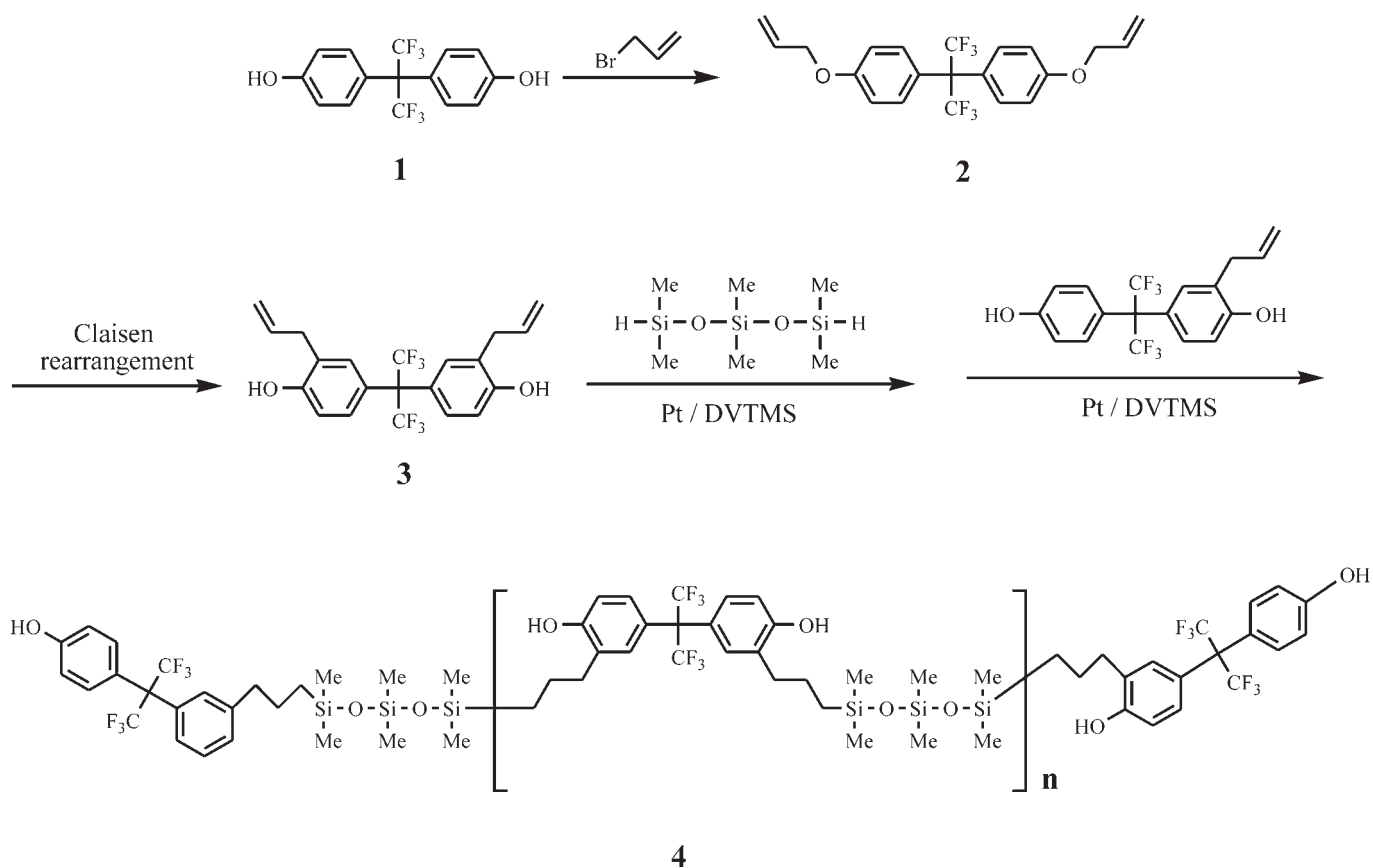

Figure 1 Synthesis of fluorosiloxane polymer (4).

Infrared (IR) spectra were recorded on a Perkin-Elmer PARAGON 500 FT-IR instrument.  $^1\text{H}$  and  $^{19}\text{F}$  nuclear magnetic resonance (NMR) spectra were recorded on a Bruker Avance DMX 300 MHz spectrometer using  $\text{CDCl}_3$  as solvent and tetramethylsilane (TMS,  $\text{CCl}_4$  solution) as reference. The abbreviations for the multiplicities of the proton and carbon signals are as follows: s singlet, d doublet, t triplet, q quartet, m multiplet. GC-MS analysis was performed using an Agilent 6890-5973 instrument (in electronic impact (EI) mode, 70 eV) with the following temperature program: initial GC oven temperature was 40 °C held for 2 min. Then, the oven temperature was programmed from 40 to 150 °C (held for 1 min) at 10 °C  $\text{min}^{-1}$ . GC-FPD analysis was performed using an Agilent 6890 GC-FPD instrument (flame photometric detector, P filter) with the following temperature program: initial GC oven temperature was 40 °C held for 1 min. Then, the oven temperature was programmed from 40 to 200 °C (held for 1 min) at 10 °C  $\text{min}^{-1}$ . The number-averaged molar mass ( $M_n$ ) and the mass-averaged molar mass ( $M_w$ ) of the fluorosiloxane were characterized by a Tosoh HLC-8220 gel permeation chromatography (GPC) system with TSK GEL G2000Hxl and GMHxl columns. Chloroform ( $\text{CHCl}_3$ ) was used as the eluent solvent at a flow rate of 1.0 mL  $\text{min}^{-1}$ . Polystyrenes with narrow molar mass distributions were used as standards to calibrate the GPC elution curve.

### 2.3. Polymer Synthesis

Figure 1 illustrates the formation of fluorosiloxane (4) from HFBA, 1. The reaction was monitored by GC-MS and FT-IR spectroscopy.

#### 2.3.1. 2,2-Bis(4-allyloxyphenyl) hexafluoropropane (2)

Allyl bromide (7.26 g, 0.06 mol) at room temperature was slowly added to a mixture of HFBA (6.72 g, 0.02 mol), sodium

hydroxide (2.4 g, 0.06 mol), toluene (30 mL), distilled water (30 mL) and tetramethyl ammonium bromide (0.2 g) in a 100 mL three-necked round bottom flask. The reaction mixture was heated in a water bath to 50 °C and stirred for 10 h. After cooling to room temperature, the organic phase was separated from the reaction mixture, and the water phase was extracted three times with 150 mL of ether. The ether extracts and the organic phase were combined. The combined solutions were washed with water to pH 7, and dried and evaporated under reduced pressure to give 8.3 g of crude product. The crude product was purified to give a colourless, transparent, oily liquid, yield 95.7%.

#### 2.3.2. 2,2-Bis(3-allyl-4-hydroxyphenyl) hexafluoropropane (3)

2,2-Bis(4-allyloxyphenyl) hexafluoropropane (2) (6.0 g) and *N,N*-diethyl aniline (50 mL) were added to a 100 mL three-necked round bottom flask. The reaction mixture was heated to 200 °C for 28 h under nitrogen. After cooling to room temperature, the mixture was evaporated to remove the solvent and then redissolved in 50 mL of toluene. The solution was washed with hydrochloric acid (6 mol  $\text{L}^{-1}$ ) and water, and dried and evaporated under reduced pressure to give 5.5 g of oily liquid. The product was purified to give a pale yellow oily liquid, yield 78.3%.

#### 2.3.3. Fluorosiloxane (4)

2,2-Bis(3-allyl-4-hydroxyphenyl) hexafluoropropane (3) (2.0 g, 0.0049 mol) and hexamethyltrisiloxane (0.9 g, 0.0042 mol) ( $[\text{Si-H}]/[\text{CH}_2=\text{CH}_2] = 1:1$  to 1.1:1) were added to a 100 mL three-necked round bottom flask. A Pt/DVTMS catalyst was added to the reaction mixture and the mixture was well stirred. The reaction mixture was heated to the reaction temperature for 8 h. Then the mixture was held for 2 h after a blocking agent was added. Activated carbon was added to the reaction mixture to

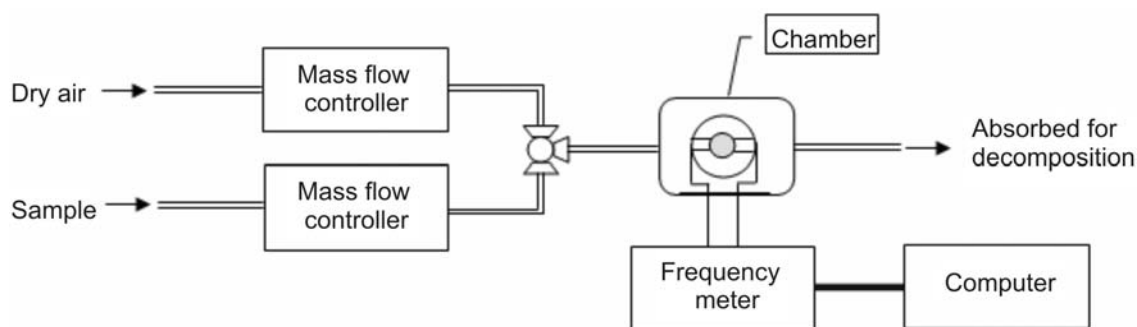

**Figure 2** Schematic diagram of the flow detection system of the QCM.

remove the catalyst. The mixture was evaporated under reduced pressure to remove solvent, dried for 10 h at 60 °C and for 3 h at 110 °C to give a green-yellow viscous product.

#### 2.4. Experimental Features of the QCM

Figure 2 is a schematic diagram of the flow detection system of the QCM. The system involves gas sample and dry air inlets, a T valve for switching of the sample gas and dry air to the sensing chamber, two mass flow controllers, a sensing chamber with the QCM, frequency meter and computer for data acquisition and analysis. The concentration of sarin gas sample was determined by GC-FPD.

The flow rate of the gas of 300 mL min<sup>-1</sup> was controlled by two mass flow controllers as the QCM sensor was sensitive to the flow rate of the gas. The sensor was placed in a thermostatic chamber (20 ± 0.5 °C), so that the sensor was free of the effect of temperature.

The coating process consisted of thoroughly cleaning and drying the quartz wafer with CHCl<sub>3</sub>; dissolving the fluorosiloxane polymer in CHCl<sub>3</sub> to prepare a series of solutions of different concentration; depositing 2 μL of the solution on both sides of the surface of the quartz wafer; and drying the quartz wafer for 30 min at 50 °C.

The sensor was measured before and after coating to determine the frequency shift caused by coating. Then the sensor could be used for the determination of sarin.

#### 2.5. Testing

The testing procedure followed two steps. Before carrying out detection of the analyte, 300 mL min<sup>-1</sup> of dry air was pumped through the sensor chamber until the rate of change in frequency of the QCM attained was <0.5 Hz min<sup>-1</sup>. That is, the QCM reached a new balance steady state. This process was observed

to take about 15 min. The detection process was started by pumping dry air initially through the sensor chamber for 1 min to establish a steady baseline. The sample gas was then pumped through the sensor chamber for 5 min to obtain the response data as a result of adsorption of sample on the QCM. After that, dry air was pumped through the chamber again until the QCM reached a new steady state value due to desorption. The latter is called 'recovery'. When the sensor reached a recovered steady state condition, a new test measurement was then carried out.

### 3. Results and Discussion

#### 3.1. Material Characterization

Quantitative conversion of 4,4'-(hexafluoroisopropylidene) diphenol (**1**) into fluorosiloxane (**4**) through 2,2-bis(4-allyloxyphenyl) hexafluoropropane (**2**) and 2,2-bis(3-allyl-4-oxyphenyl) hexafluoropropane (**3**) was monitored by GC-MS, IR, GPC and NMR. The results are shown in Table 1.

Figure 3 is the IR spectrum of fluorosiloxane (**4**). In the silylation reaction, the disappearance of Si-H stretching of 1,1,3,3,5,5-hexamethyltrisiloxane at 2127 cm<sup>-1</sup>, monitored by FT-IR, indicated that conversion to fluorosiloxane was complete. The <sup>1</sup>H NMR data were consistent with the literature.<sup>14</sup>

Different polymeric degree products could be obtained by adding 2,2-bis(3-allyl-4-hydroxyphenyl) hexafluoropropane (**3**) and hexamethyltrisiloxane ([Si-H]/[CH<sub>2</sub>=CH<sub>2</sub>]) at different ratios from 1:1 to 1:1.5. The influences of catalyst and temperature were also tested, but there were no obvious effects on the experiment.

#### 3.2. Selection of Coatings

The products with various molar masses had different responses to sarin gas (see Fig. 4). The experimental results indicated that the material with a lower polymeric degree had better

**Table 1** Reaction monitoring.

Starting material	Product	Reaction monitoring
1	2	GC/MS ( <b>2</b> ): t <sub>R</sub> :10.039 min MS (EI): m/z 416 (M <sup>+</sup> ), 347 (M-CF <sub>3</sub> ), 133 (Ph-O-C <sub>3</sub> H <sub>5</sub> ) IR (film): 1024 cm <sup>-1</sup> (=CH-O), 3444 cm <sup>-1</sup> (-OH) peak in <b>1</b> disappeared <sup>1</sup> H NMR (CDCl <sub>3</sub> ): δ (-OCH <sub>2</sub> ) 4.5–4.6 ppm (d)
2	3	GC/MS ( <b>3</b> ): t <sub>R</sub> :11.28 min MS (EI): m/z 416 (M <sup>+</sup> ), 347 (M-CF <sub>3</sub> ) IR (film): 3345 cm <sup>-1</sup> (-OH) <sup>1</sup> H NMR (CDCl <sub>3</sub> ): δ (ArCH <sub>2</sub> ) 3.3–3.4 ppm (d), (-OCH <sub>2</sub> ) in <b>2</b> disappeared
3	4	IR (film) ( <b>4</b> ): 3310 cm <sup>-1</sup> (-OH), 2959 (-CH <sub>3</sub> ) <sup>1</sup> H NMR (CDCl <sub>3</sub> ) δ (Ar-H) 6.7–7.3 ppm (m), (OH) 3.5–3.6 ppm (q), (Si-CH <sub>3</sub> ) 0.1–0.5 ppm (m), (CH <sub>2</sub> protons) 1.2–2.9 ppm (m) <sup>19</sup> F NMR (CDCl <sub>3</sub> ): δ (-CF <sub>3</sub> ) 63.7 ppm (t) GPC: M <sub>n</sub> = 1400, M <sub>w</sub> = 1400

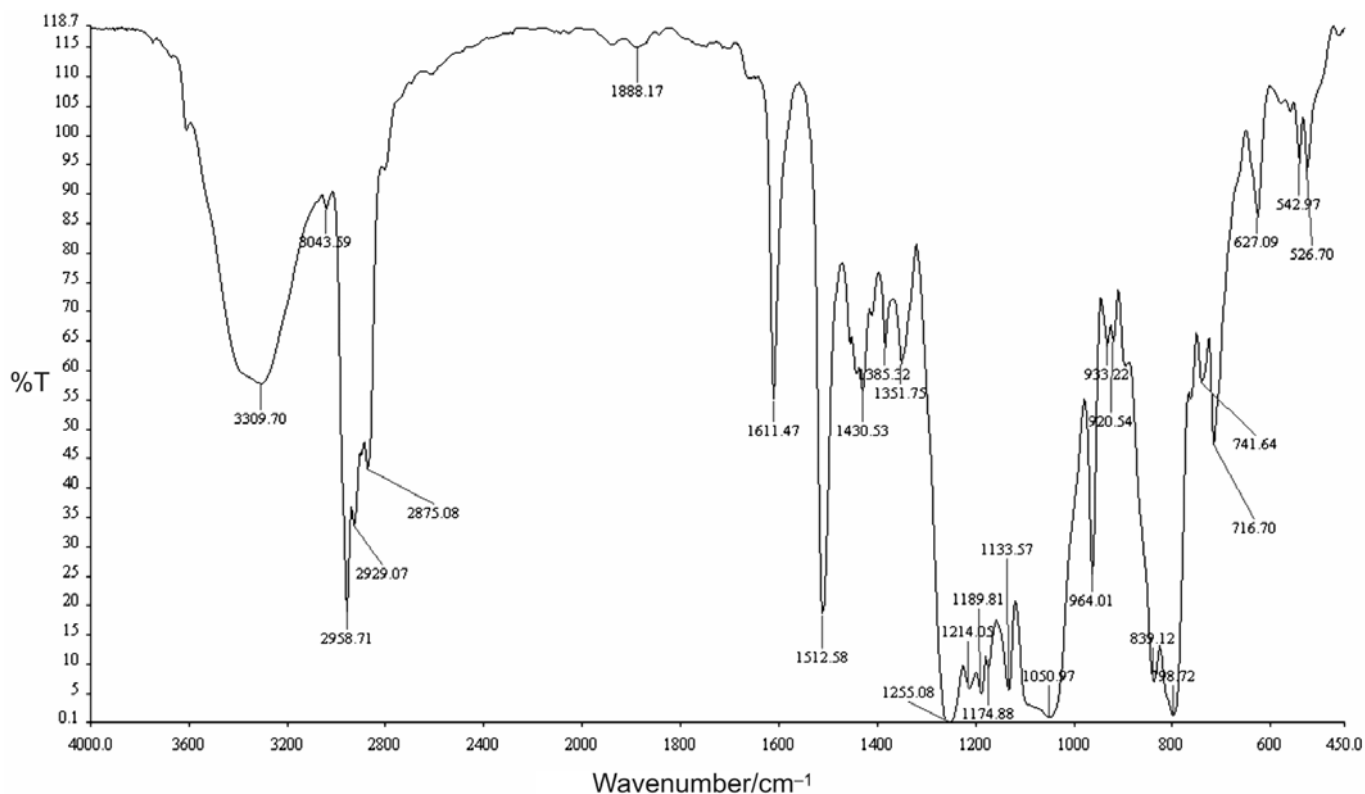

Figure 3 IR spectrum of fluorosiloxane polymer (4).

reversibility and lower response time. This may be partially caused by the decrease of freedom of rotation of the molecular chain following the increase of polymeric degree. Since the polymer is a multi-substituted compound, the higher the polymeric degree, the higher the steric hindrance. Higher steric hindrance makes adsorption and desorption of the analyte more difficult. Therefore, the product with the lowest polymeric degree was selected as the coating material used in the latter experiments. Meanwhile, desorption time could be decreased

by increasing desorption temperature, as an increase of temperature can help the molecules overcome the energy barrier of desorption. As shown in Fig. 5, when the temperature increased to 65 °C, the sensor recovered completely within 30 s.

### 3.3. Coating Thickness

The thickness of the polymer coating on the QCM had an effect on the sensitivity of the sensor. The relationship between

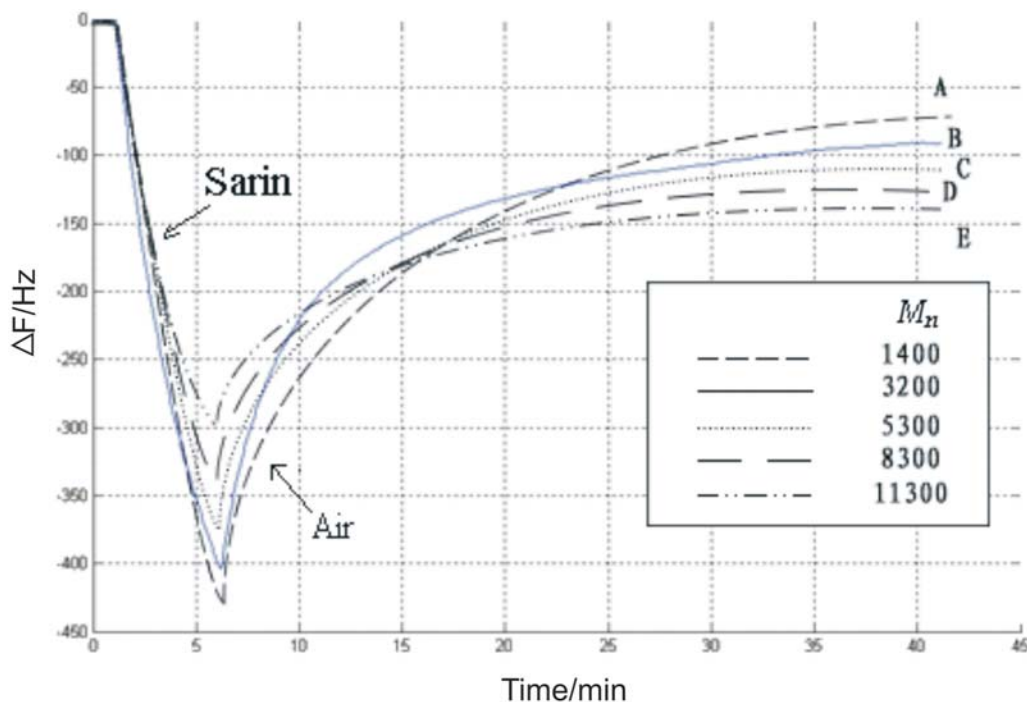

Figure 4 Responses of different coatings to 5.40 ppm sarin ( $M_n$ : A < B < C < D < E).

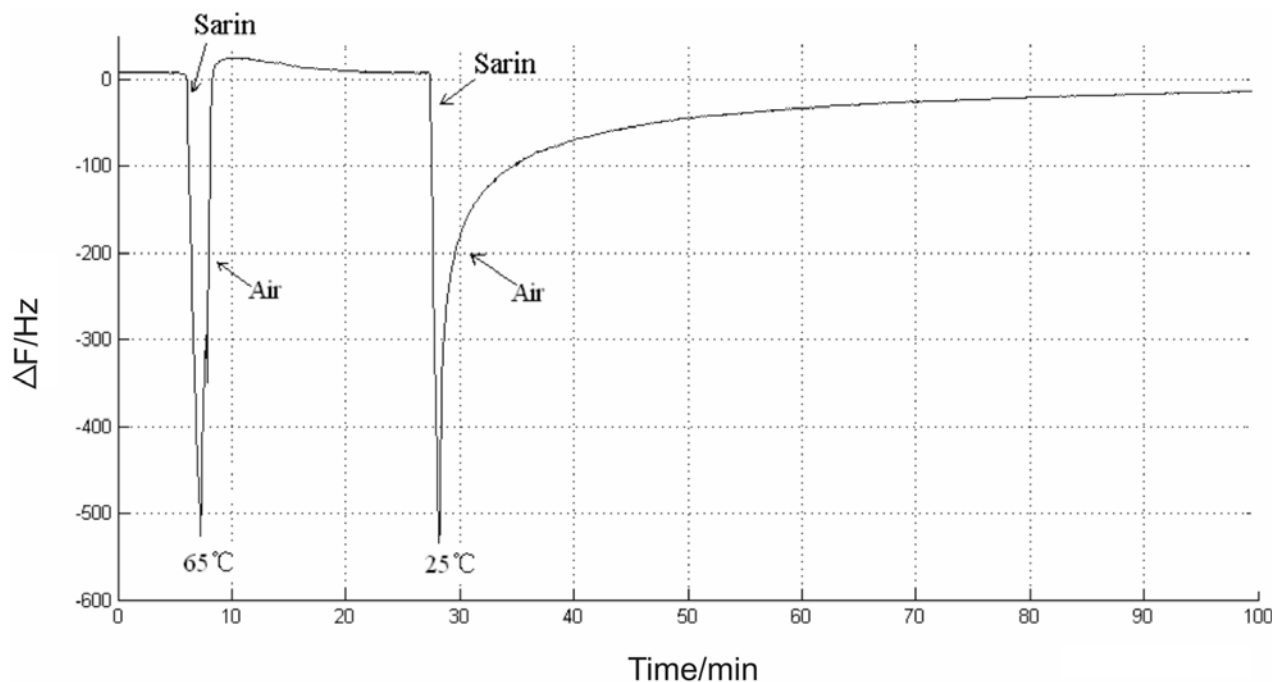

Figure 5 Effect of the desorption temperature (6.66 ppm of sarin).

the frequency shift of the sensor caused by coating and the thickness of the coating followed the Sauerbrey equation.<sup>3</sup> Figure 6 shows the response of the sensor to 1.80 ppm of sarin expressed as different frequency shifts after coating. The relationship indicated that a thicker coating material would result in a higher response than a thinner one at the same concentration of sarin. This may be caused by the increase in the number of reacting sites. The number of reacting sites, which is the most important effect on the response of the sensor, will be increased with an increase in the thickness of the coating. However, when the change of mass on the QCM sensor was higher than 11  $\mu\text{g}$ , an uneven film would be formed. The entire following test was performed using the QCM sensor with a change of mass on the QCM sensor of 4.6  $\mu\text{g}$ , caused by coating which can be related with the thickness of the coating material following Sauerbrey's equation.

### 3.4. Linear Range and Detection Limit

The responses of the sensor to the different concentrations of sarin gas are shown in Fig. 7. In Fig. 7, the downward peaks

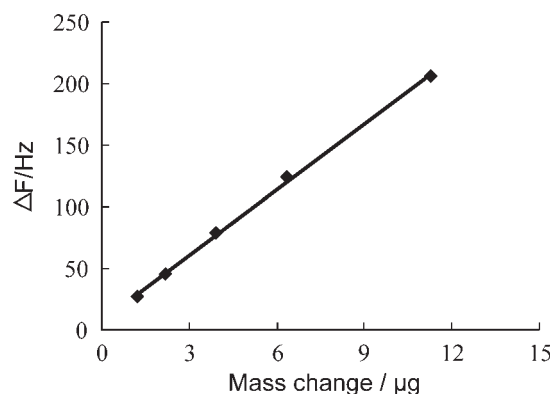

Figure 6 Response of the sensor versus change in mass with varying coat thickness (1.80 ppm of sarin).

represent the analyte while the upward peaks are air troughs (blank carrier phase). The relationship of the responses of the sensor versus the concentration of sarin showed good linearity in our experiment. The calibration curves of the response of the

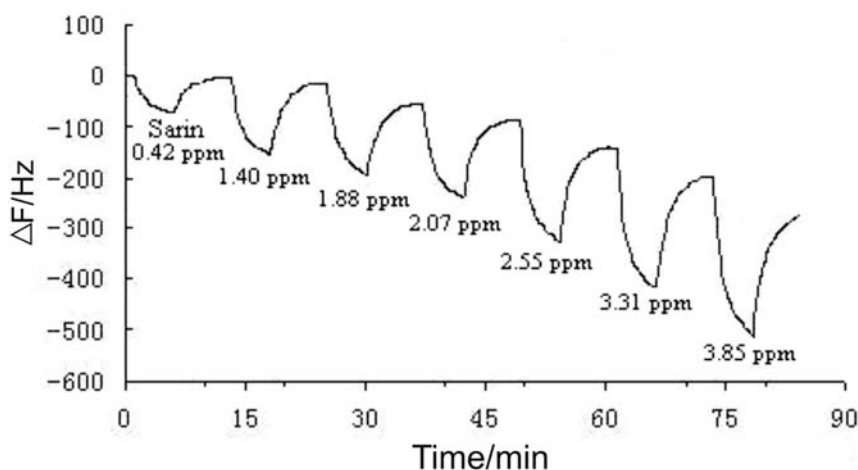
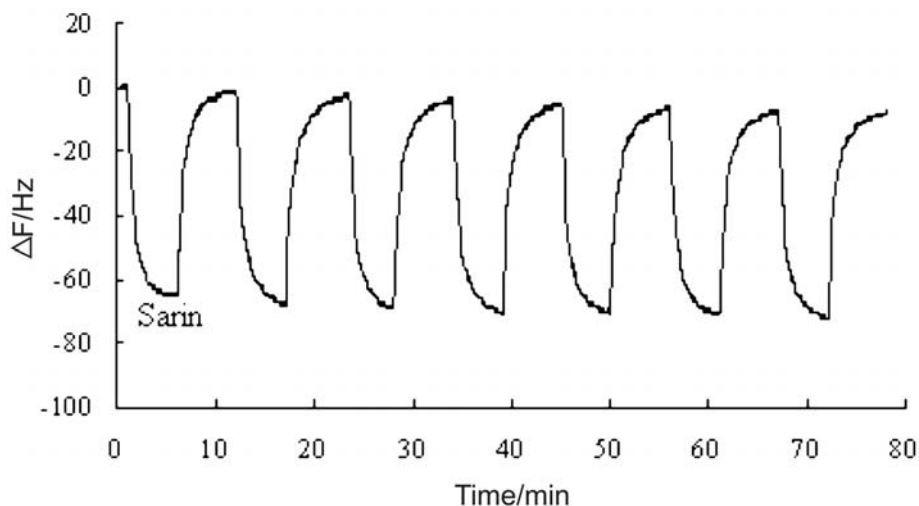

Figure 7 Response of the sensor versus the concentration of sarin.

**Table 2** Reproducibility of the sensor (1.13 ppm of sarin).

Sample	Results/Hz					Average/Hz	Standard deviation	RSD/%	Relative error/%
	1	2	3	4	5				
Sarin	124	126	123	130	127	126	2.74	2.17	3.2 to -2.4

**Figure 8** Repeatability of the sensor (0.42 ppm sarin).

QCM sensor had good linearity over the concentration range of 0.42 to 3.85 ppm of sarin. Since the response of the sensor for 0.42 ppm of sarin was still higher than 70 Hz, a detection limit of 0.15 ppm was obtained (the signal to noise ratio is 3).

### 3.5. Repeatability and Reproducibility

The same sensor was used to detect 0.42 ppm of sarin seven times. The relative standard deviation (RSD) of the response was less than 3%, showing the good precision of the determination of the sensor. Figure 8 shows the result.

After 100 tests, the response of the QCM sensor reduced by only 3%, showing that the sensor had long life.

Five different QCM sensors were used for the detection of sarin to study the reproducibility of the fabrication of the QCM sensor. The RSD of the test was less than 3%, showing good

consistency of fabrication of the sensor. Table 2 shows the results.

### 3.6. Selectivity

Mustard gas is also one of the highly toxic vesicant warfare agents that should be investigated for its toxic properties for people and the environment. Because of the difference in the toxic properties and the emergency treatments for the two compounds, mustard gas should be considered in any environmental screening protocols for sarin. In this study, mustard gas was tested as an interference to investigate the selectivity of the sensor. The response of the sensor for sarin was compared with that of mustard gas to investigate the selectivity of the sensor. Figure 9 shows the selectivity test by comparing the response to sarin with that to mustard gas. In most cases, the sensitivity to

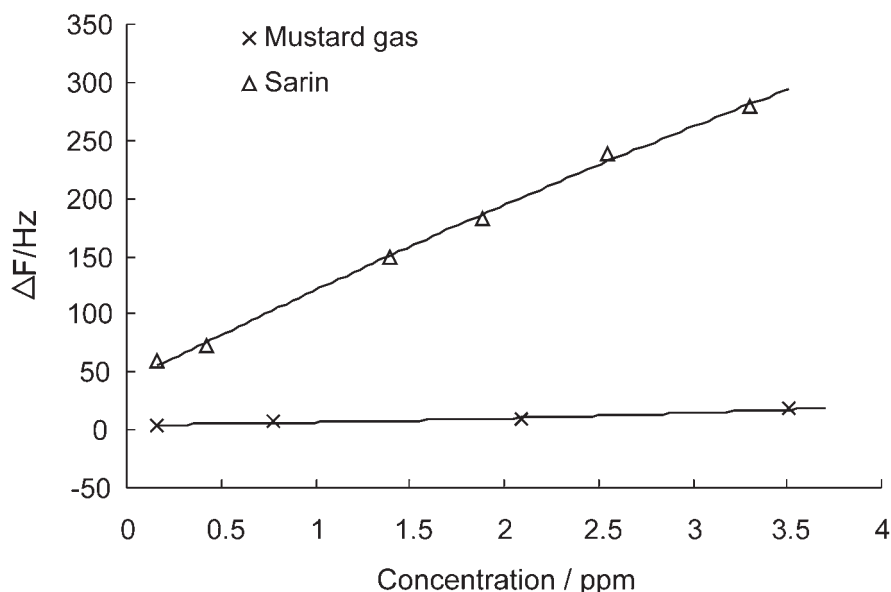
**Figure 9** Selectivity test of the response to sarin compared with that to mustard gas.

mustard gas was about ten times less than that of sarin. The material synthesized has inherent properties in HFBA. The hydrogen bond acidity of the principal functional OH group in phenols is substantially increased by electron-withdrawing halogen substituents, with the result that the basicity is decreased at the same time. Thus, the synthesized fluorosiloxane is an excellent hydrogen bonding acid with negligible base strength. Organophosphorus compounds such as sarin have a P=O functional group that shows hydrogen bond basicity, while mustard gas has no functional group that has hydrogen bond basicity. Therefore, the sensor coated with the synthesized material has good selectivity to basic gases. Furthermore, because dry air was used as the carrier gas in the test, compounds in air would not affect the detection of sarin under environmental conditions.

#### 4. Conclusion

A fluorosiloxane polymer, which was used as a QCM coating material for sarin, was synthesized through a three-step reaction from 4,4'-(hexafluoroisopropylidene) diphenol. A QCM sensor coated with the synthesized polymer was utilized for the determination of sarin. Determination was based on the frequency shifts due to the adsorption and desorption of compounds at the surface of a modified quartz crystal electrode. The frequency shifts were found to behave linearly with the concentration of the analyte in the concentration range from 0.42 ppm to 3.85 ppm. A test of selectivity showed that selective adsorption is the dominant reaction. The performance of the sensor did not decline obviously after being used more than 100 times. The

detection was performed in air, indicating that the monitoring of sarin in a real environment was possible. The method could be beneficial for further studies of sarin in the environment.

#### Acknowledgement

We gratefully acknowledge financial support of this work by the National Natural Science Foundation of China (No. 20605027).

#### References

- 1 C.K. O'Sullivan and G.G. Guilbault, *Biosens. Bioelectron.*, 1999, **14**, 663–670.
- 2 B.L. Zuo, S.M. Li, Z. Guo, J.F. Zhang and C.Z. Chen, *Anal. Chem.*, 2004, **76**, 3536–3540.
- 3 G. Sauerbrey, *J. Physik*, 1959, **155**, 206–222.
- 4 H.H. Huang, J. Zhou, S.Y. Chen, L. Zeng and Y.P. Huang, *Sens. Actuators B*, 2004, **101**, 316–321.
- 5 J.W. Grate and M.H. Abraham, *Sens. Actuators B*, 1991, **3**, 85–111.
- 6 A. Mirmohseni and A. Oladegaragoze, *Sens. Actuators B*, 2004, **102**, 261–270.
- 7 H.J. O'Neill, K.L. Brubaker, J.F. Schneider, L.F. Sytsma and T.A. Kimmell, *J. Chromatogr. A*, 2002, **962**, 183–195.
- 8 C. Zimmermann, P. Mazein, D. Rebière, C. Déjous, J. Pistré and R. Planade, *IEEE Sens. J.*, 2004, **4**, 479–488.
- 9 C. Zimmermann, D. Rebière, C. Déjous, J. Pistré, E. Chastaing and R. Planade, *Sens. Actuators B*, 2001, **76**, 86–94.
- 10 D. Rebière, C. Déjous, J. Pistré, R. Planade, J.F. Lipskier and P. Robin, *Sens. Actuators B*, 1997, **43**, 34–39.
- 11 P.S. Bhadury, B. Dubey, S. Singh and C. Saxena, *J. Fluorine Chem.*, 2005, **126**, 1252–1256.
- 12 C.Y. Shen, Y.T. Shen and L. Wu, *J. Mater. Sci.*, 2002, **37**, 295–301.
- 13 L.J. Mathias and C.M. Lewis, *Macromolecules*, 1993, **26**, 4070–4071.