



Experimental Study on Effect of Magnetic Field on Flow Dynamics of Iron (III) Oxide (Fe_2O_3) - Water Based Nanofluid using Taylor Couette Flow Apparatus

A. O. Muritala^{*1}, S. A. Adio¹, O. Luqman¹, O. S. Adebayo¹, I. J. Akinlolu¹, S. O. Obayopo¹

¹ Department of Mechanical Engineering, Obafemi Awolowo University, Ile-Ife, Osun State, NIGERIA.

Abstract

Experimental investigation of magnetic field effect on Fe_3O_4 -Water based nanofluid undergoing Taylor Couette flow is of great importance since some lubricating systems are replicas of Taylor Couette flow. In this study several experiments were carried out to investigate the influence of nanoparticle concentration on the vortex dynamics of a water based Newtonian nanofluid formulated from Fe_2O_3 in the presence and absence of magnetic field. Flow dynamics was studied in relation to flow transition, stability, hysteresis and effect of magnetism on these properties. Flow regimes covered in this study include Circular Couette flow, Taylor vortex flow, wavy Vortex flow and Modulated Wavy vortex flow. Bifurcation parameters are nanoparticle volume fraction, inner cylinder rotating frequency and Reynolds number. Experiments were performed on distilled water and Fe_3O_4 -Water based nanofluid to understand its behavior in Taylor Couette apparatus. Critical Reynolds number, Azimuthal wavenumber and travelling waves frequency was recorded for each nanoparticle volume fraction. Power Spectral Analysis of nanofluid flow was carried out using video data from the experiment. It was observed that critical frequency for various transitions decrease with nanoparticle volume fraction for nanofluid in the presence of magnetic field but an inconsistent pattern was observed for nanofluid in the absence of magnetic field. These results show that magnetic field and nanoparticle volume fraction greatly influence the behavior of the flow.

Keywords: Taylor Couette flow; magnetic field; nanoparticle; Reynold number and vortex flow.

1.0 INTRODUCTION

Taylor Couette flow is the flux of a viscous fluid in the space between two coaxial cylinders with the smaller (inner) cylinder rotating at a given angular velocity while the bigger (outer) cylinder is stationary [1]. Figure 1 shows the system configuration of a Taylor couette flow apparatus which was first designed and used by a French physicist named Maurice Couette in experimental determination of fluid viscosity. This flow was steady, azimuthal, at low angular velocity and basically known as Circular Couette flow. Sir Geoffrey Ingram Taylor performed further investigation on the stability of Couette flow and discovered that when the angular velocity of the rotating cylinder is increased above a particular threshold, Couette flow becomes unstable giving rise to a secondary

steady state characterized by an axisymmetric toroidal vortex which he called Taylor vortex flow. The combination of Couette and Taylor flow gave rise to the Taylor-Couette flow. Subsequently, as the angular velocity of the inner cylinder is further increased, other unstable flow regimes emerge, such as wavy vortex flow (WVF), modulated wavy vortex flow (MWVF) and chaotic flow.

Nanofluid (liquid based mixtures with nanoparticle suspensions) was introduced into Taylor-Couette flow when the need arose for improvement of thermal and flow characteristics of lubricant and power fluid. Recent work by Masoud and et al, [3], on a high-speed Taylor-Couette system (TCS) developed for studying drilling fluids at different rotational speeds using water-based mud (WBM) drilling fluid with addition of Al_2O_3 nanoparticles. For Al_2O_3 nanofluids especially at lower volume concentrations, considerable power saving was observed. Nanofluids generally exhibit better performance characteristics than base fluid which makes them most suitable for various engineering applications. Nanoparticles used in nanofluid applications range from metals, oxides, carbides, or carbon nanoparticles, and iron oxide [4] which is used in this experiment that demonstrated conceptual

*Corresponding author (Tel: +234 (0) 8035645318)

Email addresses: muriadam@gmail.com (A.O. Muritala), saheedadio@gmail.com (S. A. Adio), oolasunkanmi@oauife.edu.ng (O. Luqman), lowoladesamuel@gmail.com (O. S. Adebayo), justusilemobayo@gmail.com (I. J. Akinlolu), and sirajolanre@yahoo.com (S. O. Obayopo)

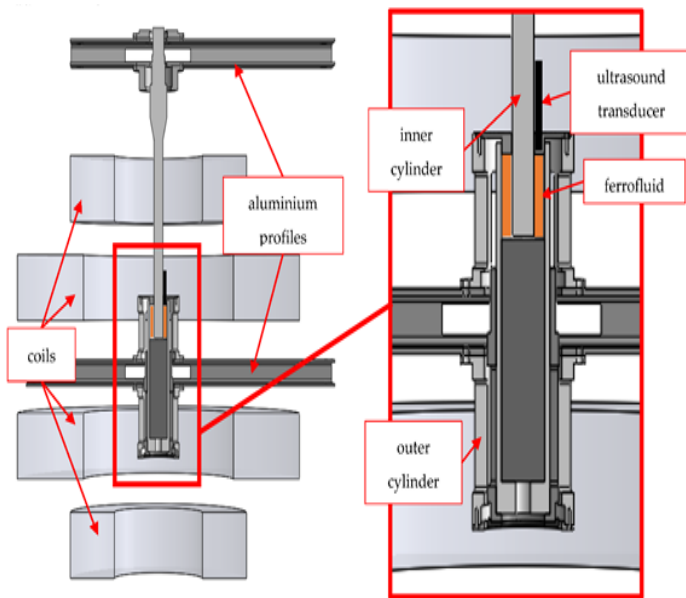

Figure 1: Modern Taylor Couette Flow Apparatus [2]

application of tribology in engineering. This branch of engineering deals with the study of lubrication with respect to friction, wear and bearing design. Nanofluid is applicable in journal bearings due to its excellent thermal conductivity at very low volume fraction ([5] & [6]). It also has excellent load carrying capacity, high extreme pressure range and lubricity.

Zhu and others in [7] investigated copper nanoparticle as additive to lubricant oil, it reduces wear and friction at higher load capacity than zinc di-thiophosphate. In recent times, nanofluid has found application in drug administration and antibacterial activities. Metallic nanoparticles such as that of gold have been used in precise drug delivery to patients and gene delivery applications due to its small size. Gold nanoparticles are said to be nontoxic and contain monolayers which allows tuning of charge and hydrophobicity which makes it suitable for drug delivery application. Magnetic nanoparticles are also very useful in nano-biotechnology and nanomedicine. Carbon nanofluids are used in delivery of bioactive proteins, peptides and nucleic acid to targeted cells and organs in the human body [8]. Nanofluid reduces both thermal resistance and the temperature difference between heated microchannel wall and coolant thereby providing better cooling performance when compared with devices using pure water as working fluid ([8] & [9]).

According to Azaditalab et al, [10], who studied skin friction reduction in a Taylor-Couette system using nanofluid containing 5W-30 hydraulic oil as base fluid with a dispersion of diamond, WS2 and MoS2 nanoparticles. The study was conducted numerically and it was observed that skin friction in the laminar flow region is affected slightly

by an increase in volume fraction (concentration) of nanofluid but decreases significantly in turbulent regime. Diamond-oil nanofluid gave minimum decrease while WS2-oil gave maximum decrease of approximately 13.8% which occurs at a Reynolds number of 4000.

Using nanofluid in Taylor Couette flow in the presence of magnetic field becomes topical research issues because of flow features that display different types of hydrodynamic instabilities that may influence lubricity of surfaces against wearing, thermal stress and thermal dissipation. Shalybkov and others in [11] investigated the stability of Taylor Couette flow (TCF) within a toroidal magnetic field and stated that the presence of a toroidal magnetic field can destabilize the Taylor Couette flow. It was observed that instability in a TCF will continue in the presence of a magnetic field even without the rotation of the moving cylinder. An important flow feature in the present research is flow instability which can be attributed to the dominance effect of electromagnetic force or viscous force. The dimensionless number that determines this instability is Hartmann number which is the ratio of magnetic force to viscous force. The flow will be destabilized if the Hartmann number exceeds some critical value.

In [12], Tagawa and others studied Couette -Taylor flow in the presence of a magnetic field using numerical method, it was discovered that the radial and azimuthal velocity can be stabilized by a vertical uniform magnetic field and that the critical Reynolds number for the flow transition increases with increase in the Hartmann number. A research on Centrifugal instability of nanofluid with radial temperature and concentration non-uniformity between coaxial rotating cylinders showed that negative temperature gradients stabilize flow, whereas positive temperature gradients destabilize it [13].

Rüdiger et al, [14], showed that the threshold for the onset of the magneto rotational instability in a Taylor-Couette flow is dramatically reduced if both axial and azimuthal magnetic fields are imposed. Sebastian Altmeyer in his study of transition to turbulence in Taylor Couette ferrofluidic flow discovered that turbulence occurs at Reynold numbers of lower magnitude (at least one order) in the presence of magnetic field for a ferrofluidic flow than in conventional flow [15].

Understanding the influence of nanofluid in Couette flow subjected to magnetic field remain unresolved due to daft of data on categories of instability encountered and identification of flow parameters that positively influence these instabilities. The specific objectives of this study are:

- i. To investigate the influence of a nanoparticle volume fraction on the transition from one flow regime to another at different Reynolds numbers.

- ii. To investigate the effect of the magnetic field on the nanoparticle and flow regime of the fluid as a whole.

2.0 METHODOLOGY

FeCl₃.6H₂O (1.52g) and PEG-20000 (1.20g) were measured using a weighing scale and then dissolved in distilled water (200ml). Hydrazine (20ml) was then added to the mixture rapidly at room temperature. The mixture turned reddish brown. The precursor suspension was heated in the microwave at 100°C, 300W for 10mins. The resulting produce is a black product suspension of Magnetite nanoparticle dispersed in a clear solution. The mixture was filtered using a filter paper and separating funnel after which it was rinsed with ethanol and then distilled water. Ethanol and distilled water are allowed to drain from product respectively. The product is then dried in an oven. A black solid semi powdered substance is recovered and blended until a perfect powdery texture was obtained. The nanoparticle is collected and stored in a cool, dry bottle at room temperature.

The method used for preparing our Fe₃O₄-water nanofluid was the two-step approach, which entails mixing of the Nanoparticle with the base fluid (distilled water). First, we determined the volume of our experimental cylinder which was found to be 80 cm³ so as to know the minimum nanofluid volume to prepare per volume fraction (concentration).

The volume fractions used were 0.002%, 0.004%, 0.006%, 0.008% and 0.01% which were found to contain 0.009 g, 0.018g, 0.027 g, 0.036 g and 0.045 g of Magnetite nanoparticle respectively. These masses were obtained from the calculation below:

Density of Magnetite nano particle = 5.00 g/cm³

Density of Distilled water ρ_{water} = 1.00 g/cm³

Volume of Distilled water = (80+10) cm³ = 90 cm³

For 0.002% volume fraction,

$$\begin{aligned} &0.002\% \\ &= \frac{V_{magnetite}}{V_{water}} \end{aligned} \quad (1)$$

$$\begin{aligned} V_{magnetite} &= V_{water} \\ &\times \frac{0.002}{100} \end{aligned} \quad (2)$$

$$V_{magnetite} = 90 \text{ cm}^3 \times 0.00002 = 0.0018 \text{ cm}^3$$

$$\begin{aligned} m_{magnetite} &= \rho_{magnetite} \\ &\times V_{magnetite} \end{aligned} \quad (3)$$

$$m_{magnetite} = 5.00 \frac{\text{g}}{\text{cm}^3} \times 0.0018 \text{ cm}^3$$

$$\begin{aligned} m_{magnetite} \\ &= 0.009 \text{ g} \end{aligned} \quad (4)$$

Where ρ is the density, V is the volume, and m is the mass of the substance.

This calculation was repeated for volume fractions: 0.004%, 0.006%, 0.008% and 0.01% and the mass of magnetite nanoparticle obtained were ($m_{magnetite}$) = 0.018 g, 0.027 g, 0.036 g and 0.045 g respectively. Calculated mass of nanoparticle for the different volume fraction was measured and transferred into a beaker, 0.015 g of anti-colloid was added to it and 90 cm³ of distilled water was added. The mixture was then sonicated in an ultrasonic bath until the agglomerated particles were dispersed in the base fluid. This took about 10 minutes and the resulting product was a dark nanofluid.

3.0 MAGNETIC FIELD DESIGN

Magnetic field between the range of 0.1 to 1.0 Tesla was used because of the established fact that 0.1 Tesla is just enough to attract small iron filings and nails. Two magnetic field sources in opposite arrangement were used, each supplying at least 0.1 Tesla. These field sources are electromagnetic in nature, consisting of a 40×40×20 mm magnetic core, 100 windings and a 2.5A electric power source. Calculations based on these parameters gave a resulting magnetic field of 0.43 Tesla.

There was fabrication of the magnetic cores from rectangular metal sheets that was cut into sizes of 40×40mm, piled together to a thickness of 20mm and welded. The magnetic field generated was observed to be intermittent which was just exactly what we needed. The appearance frequency of the magnetic field was estimated to be once in every 1.5sec.

Various parameters were put into consideration during this design and they are; relative permittivity of the magnetic core material (μ), number of coil turns (N), dimension of each electromagnet (L), Power source output current (I), Magnetic flux (Φ), Magnetic flux density (B)

4.0 EXPERIMENTAL SETUP

The setup consists of a Taylor Couette flow apparatus, high definition camera, laptop (core i7), thermocouple thermometer, two electromagnets, and a light bulb as shown in Figure 2. The Taylor Couette flow apparatus consist of an electric motor, 2 concentric cylinders (with the outer stationary while the inner is connected to the shaft of the electric motor and rotates with it), an electric module with Arduino board, fluid inlet valve

and a round opening at the top of the cylinder for injecting marker into the cylinder which also acts as a pressure relief. The electric module which consists of an Arduino board has two ports, the first is connected to the power source while the second is connected to the laptop through a USB cable.

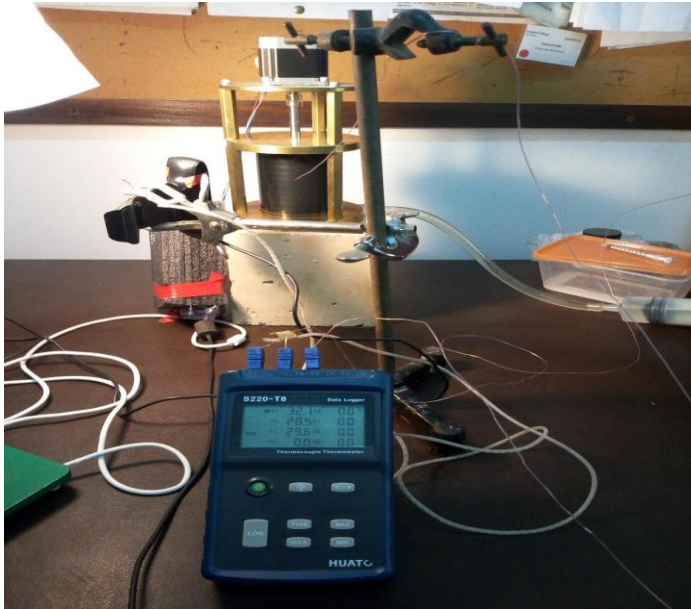

Figure 2: Experimental setup

The high speed camera was mounted on a stand and positioned to get the best captured view of the flow dynamics observed during the course of the experiment, a cord from the camera was connected to the laptop for visualization, monitoring and modifying the captured image.

The laptop acts as the monitoring and conditioning device, it was used in the analysis and storage of data gotten from the camera and in controlling the rotation of the electric motor. The thermometer was majorly used to monitor the ambient temperature in order to control the temperature factor which has an effect on the fluid viscosity. Three thermocouple probes were used and their various readings were displayed on the thermometer, one probe was placed close to the camera which was in close proximity to the light source, the second was placed very close to the outer (stationary) cylinder while the last was placed somewhere in the room, far from the experimental setup. The temperature at the cylinder was maintained at $29.4 \pm 1^\circ\text{C}$.

The two electromagnets used were placed directly opposite each other on the diameter of the cylinder at a distance of about 1.5 cm from the outer cylinder. This arrangement was such that the south pole of one cylinder is placed facing the north pole of the other in order to obtain a constructive magnetic field.

4.1 Water Experiment

Distilled water was used as the fluid in this experiment. The water was injected into the cylinder gap through the fluid inlet hose until it was filled to the annulus. Kalliroscope fluid (suspended tiny flat flakes in fluid) was added to the water from the opening at the top of the cylinder. The cylinder was then rotated at an acceleration rate of 0.02rev/s^2 to a frequency of about 2 Hz to ensure proper mixture of both fluids. The rotating frequency was brought back to zero after observing fluid homogeneity. The cylinder was then accelerated from rest until Taylor vortices were observed to form. Frequency at which Taylor vortices observed was recorded, this frequency is called the critical frequency ($f_{cyl}c$) or onset of Taylor instability.

Various flow patterns were observed at different Reynolds numbers. These patterns were made visible by “Kalliroscope” or “rheoscopic” fluids. Hysteresis was determined by gradually reducing cylinder rotating frequency until Taylor vortices disappeared. Hysteretic frequency was then recorded and denoted as f_{hys} . The cylinder rotating frequency f_{cyl} was gradually increased above the onset of Taylor vortices until traveling azimuthal waves were formed on the Taylor vortex, this frequency was marked as the onset of wavy vortices and was recorded and denoted as f_{wav} .

4.2 Nanofluid Experiment

The nanofluid experiment follows the same procedure as the water experiment. The major difference is that the distilled water was replaced with Iron (III) oxide nanofluid. All other factors and conditions were similar to the base experiment (water experiment). The nanofluid experiments were carried out in the presence and absence of magnetic fields. Two electro magnets were placed directly opposite each other on the diameter of the cylinder at about 1.5cm from the outer cylinder. This was done so as to achieve a constructive magnetic field.

5.0 RESULTS

5.1 Water and Nanofluid Experimental Result

These results in Tables, 1, 2 and 3 were obtained based on the procedure stated in the water experiment procedure and is subject to change if the procedure is not followed strictly. The values were obtained by maintaining the temperature of the cylinder at $29.4 \pm 1^\circ\text{C}$ and taken at different angular velocities. From various experiments performed, the onset of Taylor vortex flow for distilled water has higher frequency compare to nanofluid. The flow under the influence of magnetic field show slight increment in frequency showing that there is retardation due to the magnetic flux. This observation can be attributed to change in viscosity motivated by nanoparticles. Other experiments

show similar results and it can be assumed that high viscous flows give higher resistance compare to distilled water.

When compare wavy vortex flow in various experiments, the highest frequency was recorded in flow with magnetic field, followed by nanofluid without magnetic field. This shows the sensitivity of nanoparticles

to magnetic field and a clear indication of improvement in performance of nanofluid in tribology. This observation can also be deduced from hysteresis frequency which is higher in magnetic influenced nanofluid. There will be a better performance of the fluid in lubrication due to moderate frequencies of vortical flow formed over the surface.

Table 1: Water experimental results

S/N	Experiment	Notation	Result
a.	Onset of Taylor Vortex Flow	$(f_{cyl})_c$	0.119 Hz
b.	Hysteresis disappeared	f_{hys}	0.114 Hz
c.	Onset of Wavy Vortex Flow	f_{wav}	0.147 Hz
d.	Frequency	$f_l = 2(f_{cyl})_c$	0.238 Hz
e.	Mode number	M	4
f.	Modulated wavy vortices	$(f_{cyl})_{mod}$	1.68 Hz

Table 2: Nanofluid experimental result (without magnetic field)

Experimental flow features	0.006%	0.008%	0.01%
a. Onset of Taylor $(f_{cyl})_c$ (Hz)	0.117	0.119	0.119
b. Onset of Taylor Hysteresis f_{hys} (Hz)	0.100	0.115	0.116
c. Onset of Wavy f_{wav} (Hz)	0.155	0.157	0.158
d. Azimuthal Wave number M	6	4	6
e. Time taken for 20 waves to pass a point at $f_{cyl} = 2(f_{cyl})_c$ (Sec)	28	38.5	39
f. Frequency f_l of traveling wave at $f_{cyl} = 2(f_{cyl})_c$ (Hz)	0.514	0.519	0.689

Table 3: Nanofluid experimental result (with magnetic field)

Experimental flow features	0.006%	0.008%	0.01%
Onset of Taylor $(f_{cyl})_c$ (Hz)	0.114	0.110	0.100
Onset of Taylor Hysteresis f_{hys} (Hz)	0.080	0.080	0.020
Onset of Wavy f_{wav} (Hz)	0.151	0.148	0.146
Azimuthal Wavenumber M	5	6	6
Time taken for 20 waves to pass a point at $f_{cyl} = 2(f_{cyl})_c$ (Sec)	33.6	29.6	37
Frequency f_l of traveling wave at $f_{cyl} = 2(f_{cyl})_c$ (Hz)	0.595	0.575	0.540

Figure 3 shows the effect of magnetic field on the flow field generated by nanofluid. A gradual reduction in the critical frequency when the fluid is subjected to magnetic field was observed.

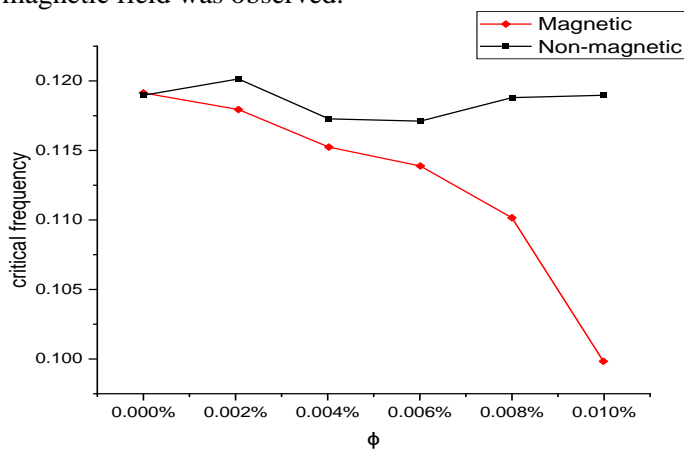

Figure 3: Critical frequency against nanoparticle volume fraction for Taylor vortex flow

It should be noted that the nanofluid used is ferromagnetic in nature; hence the action of magnetic field on the nanofluid causes a reduction in flow. This is true because, the magnetic field causes extra resistance to the flow. The critical frequency of the nanofluid reduces as the nanoparticle volume fraction increases. For nanofluid in the absence of a magnetic field, the critical frequency was seen to decrease with increase in nanoparticle volume fraction before slightly increasing at 0.008% nanoparticle volume fraction. The difference in the margin for each nanoparticle volume fraction in the absence of a magnetic field was small compared to that in presence of magnetic field. The change in trend seen in the absence of magnetic fields may be due to environmental factors such as temperature.

Figure 4 shows the nanoparticle volume fraction against critical frequency of wavy vortex flow. The behavior for wavy vortex flow in the presence and absence of magnetic fields seems to follow a similar pattern in terms

of increase and decrease in frequency. In the presence of magnetic field, the critical frequency reduces at 0.006%

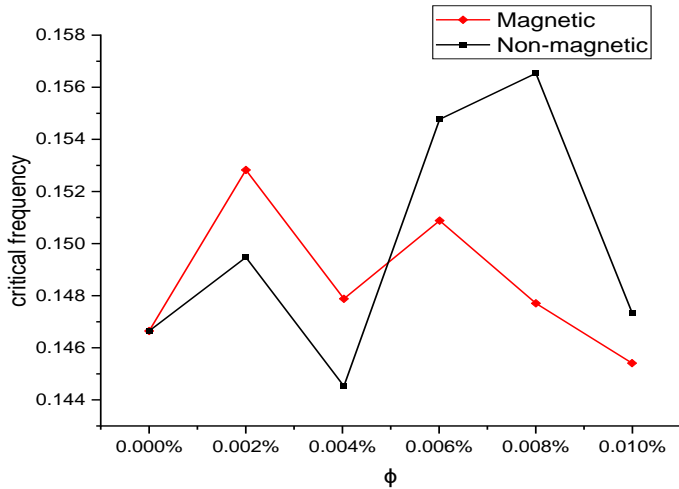

Figure 4: Critical Frequency against Nanoparticle Volume Fraction for Wavy vortex flow

volume fraction. Whereas, such a decrease started at 0.008% volume fraction for non-magnetic flow and there was sudden decrease in critical frequency that portend long term instability. Both flow exhibited decrease in critical frequency but nanofluids under the influence of magnetic field shows a gradual decrease and more stability compared to non-magnetic condition.

The hysteresis curve (Figure 5) shows the point where Onset of Taylor vortex flow disappears. This was achieved by gradually decelerating the velocity of the cylinder by 0.01 m/s^2 from the initial speed that generated the Taylor vortex under consideration. From the experiment, the presence of the magnetic field motivated a gradual decline in the hysteresis curve. In the absence of magnetic field, there was no huge decrease in the flow apart from the one noticed at 0.008% nanoparticle volume

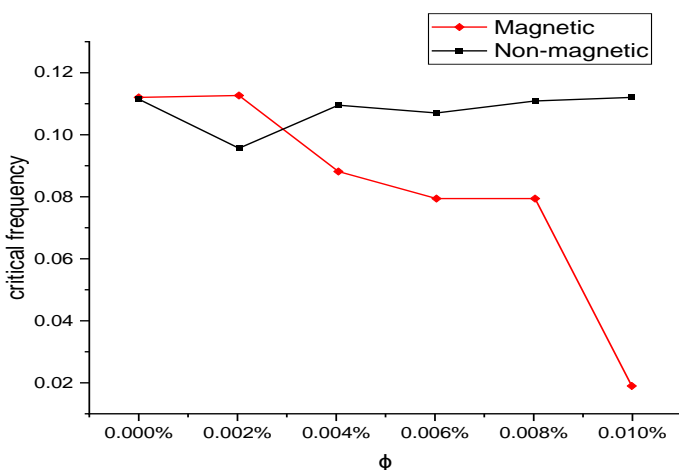

Figure 5: Critical frequency against Nanoparticle volume fraction for Hysteresis of TVF

It can be deduced that hysteresis for different nanoparticle fractions was constant. This means that for different nanoparticle volume fraction the onset of Taylor vortex flow disappears almost at the same frequency.

5.2 Power Spectral Analysis for Onset of TVF

A spectral analysis of the onset of Taylor vortex flow at 0.002% nanoparticle volume fraction in the absence and presence of magnetic field are shown in Figure 6. Both graphs show a similar trend with little spikes indicating that magnetic field intensity has little or no influence on the flow dynamics. This also indicate that the flow is stable. However, for a 0.004% nanoparticle volume fraction, in the presence of magnetic field there were more ripples (Fig. 7b) compared to both lower nanofluid concentration and absence of magnetic field (Fig. 6 and 7a). This implies that there is more instability as a result of more ferro-material fluid in the system.

Visual inspection of Figure 8a shows there is no significant increase in ripples when compared with Figure 6a and 7a, the additional ripples observed in Figure 7b and 8b may not be totally attributed to increase in nano-particles but presence of magnetic field, without magnetic field the instability may not be significant as observed. Excessive ripples shown in Figure 9b indicate that there is a threshold volume fraction of nanoparticle that is present which when subjected to magnetic field will create more instability than will ordinarily happen.

From the power spectral analysis for onset of wavy vortex flow, increase in nanoparticle volume fraction affects the flow instability as shown in Figure 10. When compare Figures 10b and 11b, a higher level of instability in the flow is observed in the presence of magnetic field at higher nanoparticle volume fraction which is denoted by more ripples and longer spikes. This instability peaks out at 0.008% volume fraction and thereafter reduced significantly at 0.01% nanoparticle volume fraction. There is speculation of a threshold nanoparticle volume fraction that affects the flow instability significantly and beyond this value the instability reduces and fades out as the volume fraction increases.

Figures 12 and 13 are the direct photographs using high speed camera of Taylor vortex flow, wavy vortex flow and modulated wavy vortex flow for nanoparticle volume fraction of 0.002% in the presence and absence of magnetic field. There is no significant difference between magnetized and the non-magnetic nanoparticle solution at nanoparticle volume fraction of 0.002%, this can be attributed to low Ferromagnetism.

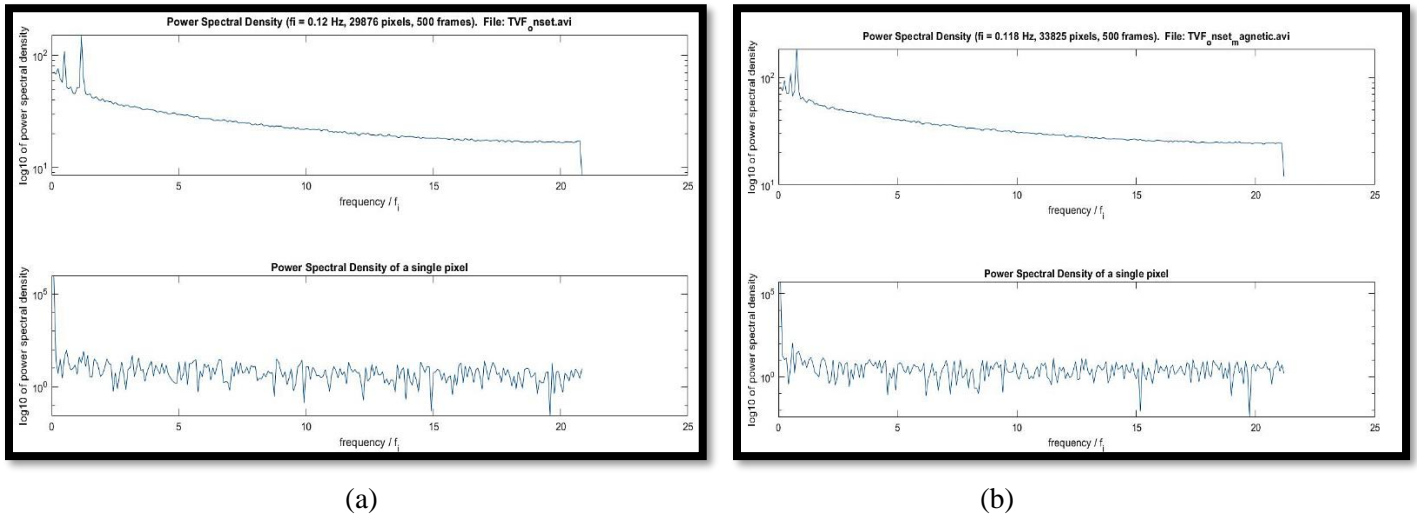

Figure 6: Onset of Taylor Vortex Flow for 0.002% nanoparticle volume fraction in the (a) Absence of magnetic field and (b) Presence of magnetic field.

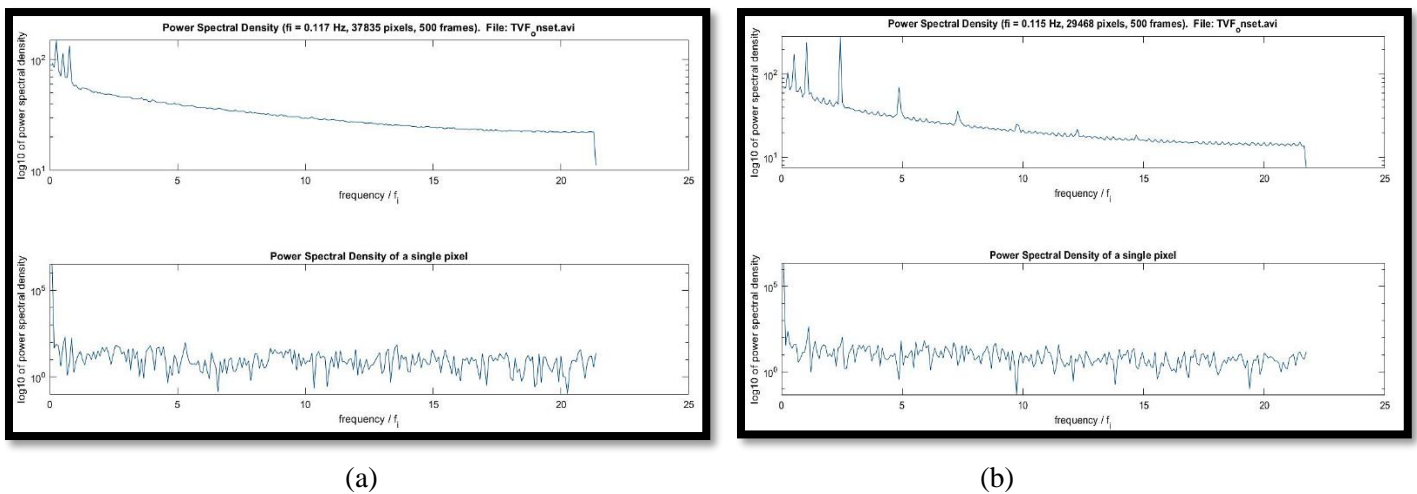

Figure 7: Onset of Taylor Vortex Flow for 0.004% nanoparticle volume fraction in the (a) Absence (b) Presence of magnetic field

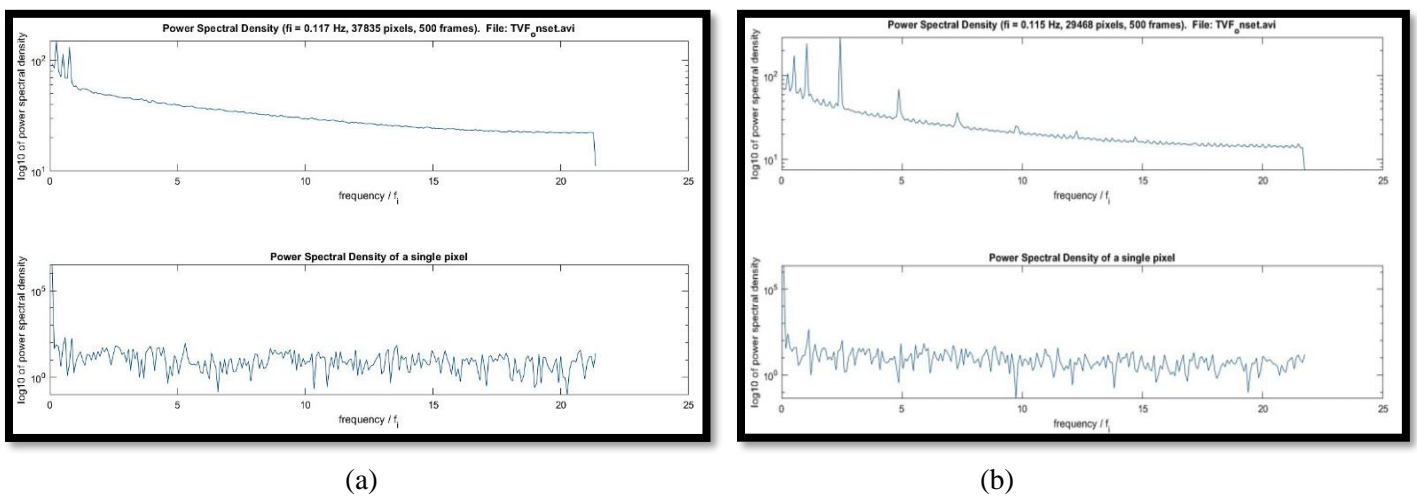

Figure 8: Onset of Taylor Vortex Flow for 0.006% nanoparticle volume fraction in the (a) Absence (b) Presence of magnetic field

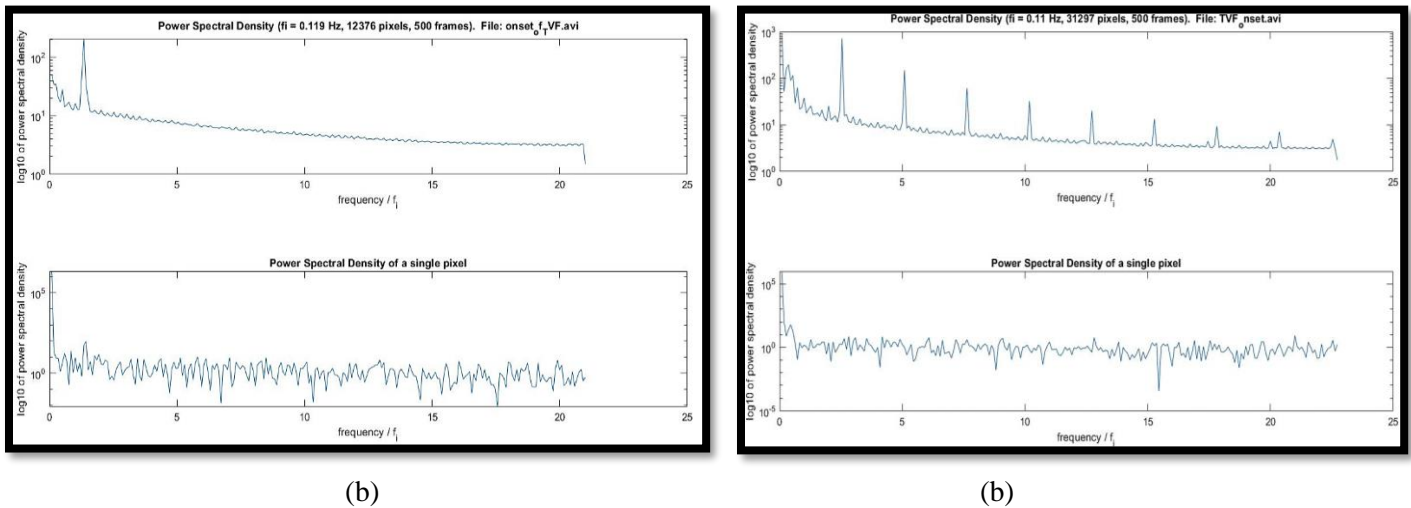

Figure 9: Onset of Taylor Vortex Flow for 0.008% nanoparticle volume fraction in (a) Absence (b) Presence of magnetic field

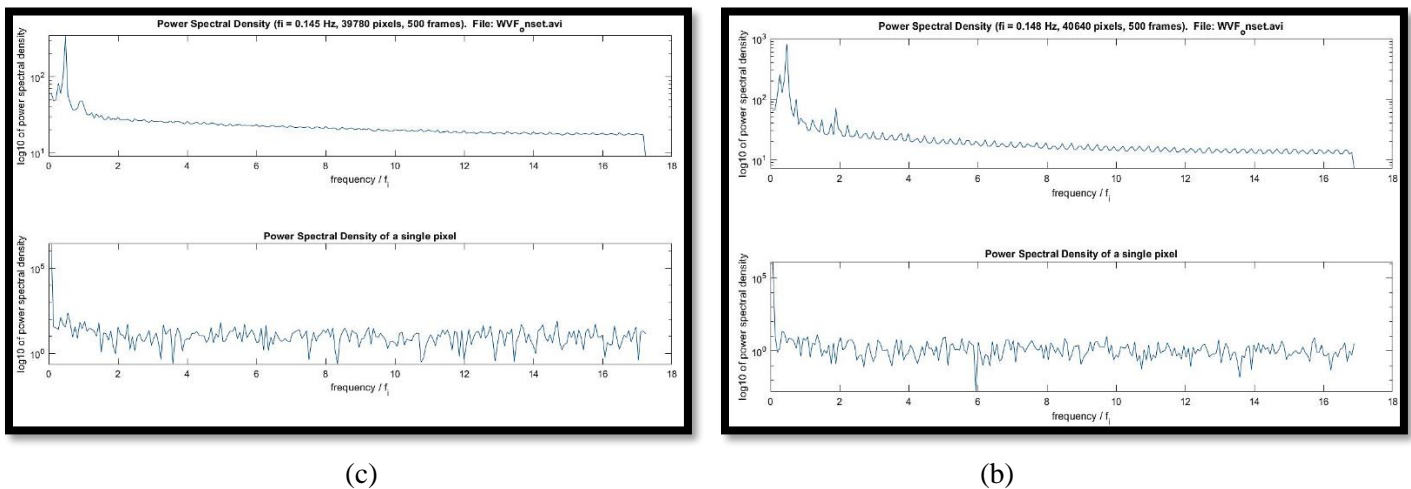

Figure 10: Onset of Wavy Vortex Flow for 0.004% nanoparticle volume fraction in (a) Absence (b) Presence of magnetic field

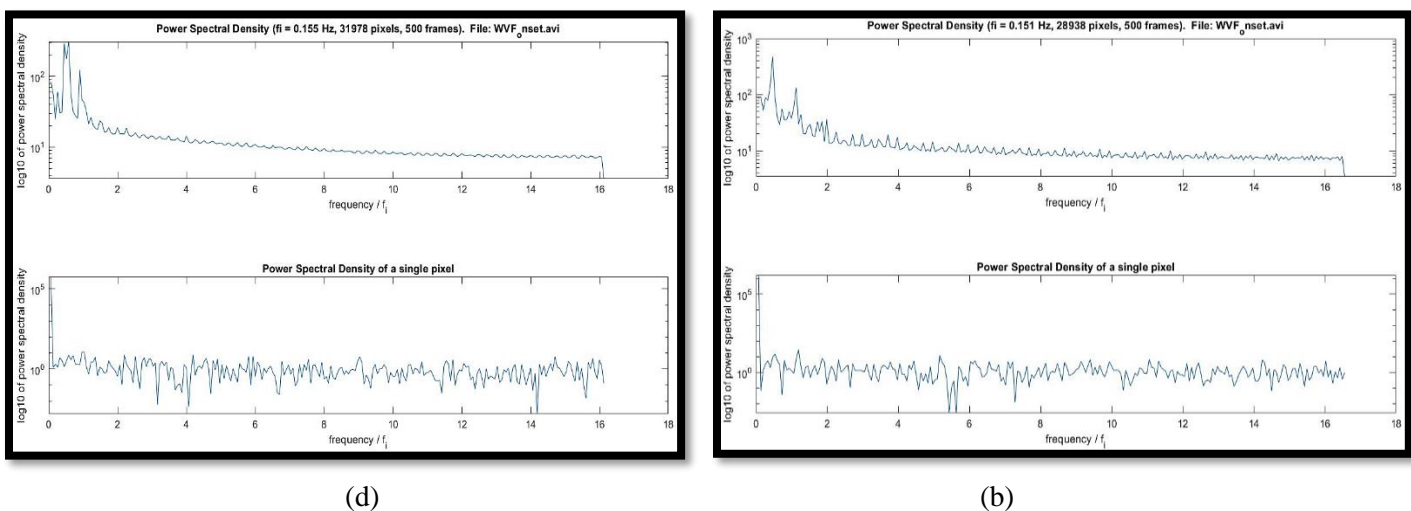

Figure 11: Onset of Wavy Vortex Flow for 0.006% nanoparticle vol. fraction in (a) Absence (b) Presence of magnetic field



Figure 12: Onset of different flow regimes in the presence of magnetic field at 0.002% nanoparticle volume fraction.



Figure 13: Onset of different flow regimes in the absence of magnetic field at 0.002% nanoparticle volume fraction.

6.0 CONCLUSION

The influence of magnetic field in the transition between different flow regimes has been investigated and the following conclusions are drawn from the analysis:

1. The critical frequency for CCF – TVF transition decreases as the volume fraction of nanoparticle increases suggesting improved performance of the fluid in lubrication.
2. Transition frequency for Taylor Vortex Flow – Wavy vortex Flow decreases for both magnetic and nonmagnetic situation with little difference when the nanoparticle volume fraction increased.
3. Hysteresis frequency for non-magnetic condition does not change significantly, however there is gradual decrease in frequency in the presence of magnetic field.

4. Generally, instability increases with increase in nanoparticle volume fraction in the absence of magnetic field while in the presence of magnetic field, instability increases steadily before decreasing at 0.01% nanoparticle volume fraction.

The outcome of the present research calls for further probing into the effect of using non-metallic nanoparticle on both magnetic and non-magnetic situation.

REFERENCES

- [1] H. S. Dou, B. C. Khoo, and K. S. Yeo, “Instability of Taylor-Couette flow between concentric rotating cylinders,” *International Journal of Thermal Sciences*, 47(11), 2008, pp. 1422–1435, doi: 10.1016/j.ijthermalsci.2007.12.012.
- [2] T. Ilzig, K. Stöckel, and S. Odenbach, “Experimental investigations on the effect of axial homogenous

- magnetic fields on propagating vortex flow in the Taylor-Couette system,” *Materials (Basel)*, 12(24), 2019, doi: 10.3390/ma1224027.
- [3] B. M. . K. V. M. S. Masoud, R., Ahmad S., “Experimental study on energy saving and friction reduction of Al₂O₃-WBM nanofluids in a high-speed Taylor-Couette flow system” *Tribology International* 154(3), 2021, doi: 10.1016/j.triboint.2020.106728.
- [4] S. K. S. and R. K. S. Shylaja, A. Manikanda, S., “Preparation and Thermo-Physical Properties of Fe₂O₃-Propylene Glycol Nanofluids,” *Journal of Nanoscience and Nanotechnology*, 15(2), 2015, p. 1653.
- [5] J. K. P. Govind R Rajput, Vishwambhar patil, “Hydromagnetic bioconvection flow in the region of stagnation-point flow and heat transfer in non-Newtonian nanofluid past a moving surface with suction: similarity analysis,” *International Journal of Heat and Technology*, 35(1), 2017, pp. 25–32.
- [6] A. K. vishiwanath Awati, “static characteristics of thermohydrodynamic journal bearing with surface roughness operating under lubricants with nanoparticles,” *Journal of Nanofluids*, 7(1), 2018, pp. 203–209.
- [7] H. Zhu, Y. Lin, and Y. Yin, “A novel one-step chemical method for preparation of copper nanofluids,” *Research gate*, 277, 2004, pp. 100–103, doi: 10.1016/j.jcis.2004.04.026.
- [8] H. Prasad, A. R., Singh, S., & Nagar, “A Review on Nanofluids: Properties and Applications,” *International Journal Advanced Research and Innovation*, 3(3), 2017, pp. 3185–3209.
- [9] J. E. R. Sorour, M. M., & Coney, “Effect of Temperature Gradient on the Stability of Flow Between Vertical, Concentric, Rotating Cylinders,” *Journal of Mechanical Engineering Science*, 21(6), 1979, pp. 403–409.
- [10] A. Azaditalab, M., Houshmand, A., & Sedaghat, “Tribology,” *Tribology International*, 2015, doi: <https://doi.org/10.1016/j.triboint.2015.09.046>.
- [11] D. Shalybkov, “The numerical simulation of Taylor-Couette flow with radial temperature gradient,” *Research gate*, 2016, doi: <https://doi.org/10.1088/1742-6596/760/1/012035>.
- [12] T. Tagawa and M Kaneda, “Numerical analyses of a Couette-Taylor flow in the presence of a magnetic field,” *Journal of Physics*, 14, 2005.
- [13] A. A. Avramenko, A. I. Tyrinov, I. V Shevchuk, and N. P. Dmitrenko, “European Journal of Mechanics B / Fluids Centrifugal instability of nanofluids with radial temperature and concentration non-uniformity between co-axial rotating cylinders,” *The European Journal of Mechanics-B/Fluids*, 60, 2016, pp. 90–98, doi: 10.1016/j.euromechflu.2016.08.001.
- [14] F. Rüdiger, G., Gellert, M., Hollerbach, R., Schultz, M., Stefani, “Physics reports Stability and instability of hydromagnetic Taylor-Couette flows,” *Physics Reports*, 2018, doi: <https://doi.org/10.1016/j.physrep.2018.02.006>.
- [15] Y. C. Altmeyer, S., Do, Y., & Lai, “Magnetic field induced flow pattern reversal in a ferrofluidic Taylor-Couette system,” *Science Reports*, 5, 2015, pp. 1–13.