



DEVELOPMENT OF MICROCONTROLLER BASED BINAURAL DIGITAL HEARING AIDS FOR HEARING-IMPAIRED PEOPLE

D. B. N. Nnadi^{1,*}, N. C. Onu², S. E. Oti³ and C. U. Ogbuefi⁴

^{1,2,3,4} DEPARTMENT OF ELECTRICAL ENGINEERING, UNIVERSITY OF NIGERIA, NSUKKA, ENUGU STATE, NIGERIA.

Email addresses: ¹ damian.nnadi@unn.edu.ng, ² cnspecial1@gmail.com, ³ stephen.oti@unn.edu.ng,

⁴ uche.ogbuefi@unn.edu.ng

ABSTRACT

This research paper expounds microcontroller based binaural digital hearing aids for hearing-impaired people by making use of ATmega328 microcontroller and other circuitries to process the audio signal input by either increasing or reducing the gain level of input audio signal, filter background noise, frequencies compression, save battery power and minimize circuit by making use of the internal ADC of the microcontroller and two PWM pins of the microcontroller as DAC. Hearing impairment among the youths and adults nowadays are in the increase, due wrong use of phones of which every minute of the day someone's earphone is on listening to one type of music or the other. In other to solve the problem created so to say this research work was conceived and given birth to. The different stages of digital hearing aid are designed and then simulated first in Proteus software which then was implemented using PCB-board. The main components of this system were the audio input unit which consists of the microphone and its pre-amplifier, the microcontroller (ATmega328) which consists of the ADC, the DAC and the audio signal processing, the filter stage and control codes (frequencies compression codes, power saver codes, acoustic feedback control codes, signal level control and adaptive adjustment codes etc.), the power amplifier and volume control unit and then the earphones (output). The control codes were written in C language while Arduino Uno compiler was used to write the codes into ATmega328. The prototype has an overall system gain of 27dB and the power output of 32.5mW. The prototype was tested with a patient that has a hearing impairment and the patient was satisfactory with the device.

Key words: Hearing loss, Digital Signal Processing ATmega328, Automatic Gain Control, amplification, noise.

1. INTRODUCTION

Hearing impairment issues are becoming serious in today's world. At present about 12% of the human population suffers from hearing problems [1] and are supposed to be potential users of hearing aids. The disorders caused by hearing impairment weakened sensitivity to the sounds normally heard by the victim. Deafness and speech acuity are two classes of hearing losses which always goes paripassu with each other. People suffering from deafness are unable to comprehend speech even in the presence of amplification. Hearing loss disturb the developing and learning procedures in children while in adults, it affects and generates hitches in the education, employment and general wellbeing. It affects the professional and personal relationships [2]. Cochlear implants and hearing aids have been developed to counter such effects but only a small portion of human population seek help and use them [3], though the reason may be due to high cost of the device, stigma following people putting it on

and lack of knowledge for those who can afford it. But with recent development of most young men and adult putting on earphones of their handset at all time, the stigma of putting on of digital hearing aid will no longer be there as before. As it can be mistaken to be earpiece of mobile phone.

Hearing aids can be classified into two types, the analog and digital hearing aids. The analog hearing aid processes the signal in analog realm while the digital hearing aid first converts the signal into digital realm and then processes it. The conventional analog hearing aids amplify all the frequencies of both the desired audio signal and the surrounding noise alike. It cannot distinguish between the desired signal and background noise. Some analog aids have different listening profiles which the user can select using a button on hearing aid [4]. The advancement in the digital technology and introduction of Digital Signal Processing (DSP) to the hearing aids has much improved the hearing aid [5]. The use of DSP offers many benefits over the analog hearing

* Corresponding author, tel: +234 – 806 – 933 – 5370

aids including the programmability, self-monitoring, acoustic feedback control, signal level control and adaptive adjustment etc. The Digital hearing supports first convert the signal into digital domain and then process it. Hence utilizing the software and proper configuration of the system, speech signal can be much improved even in the presence of noise.

The device that the hearing-impaired individuals use to compensate for their hearing loss is known as hearing aids. Hence, the main objective of a hearing aid is to fit the dynamic range of speech frequencies into the circumscribed dynamic frequencies series of the impaired-ears. It has been designed to pick up sound waves with a microphone, strengthen the weak sound waves into strong or loud sound waves and send them to the ear through a speaker [6]. With the microchips, available today, hearing aids have become smaller and smaller and have significantly improved in quality [7]. These devices may not completely overcome the shrewdness discrepancies caused by a hearing loss but support the user to interpret speech. Human ear detects and analyzes sound waves by transduction (i.e. by converting sound waves into electrochemical impulses) [8].

The frequencies produced by the wave shows the pitch of sound wave while the amplitude of such wave depicts the loudness of sound and the tone of sound is detected by various frequencies that make up a complex sound wave [9]. The normal hearing of a person may get affected due to various factors including age, noise (especially people working where noise pollution is high), genetic disorders illness, physical trauma maybe resulting from accident, constant use of handsets for listening to music at high pitch, birth disorder etc.

Two common types of hearing loss are Presbycusis and Meniere's disease. Presbycusis is an age-related hearing loss that occurs in the high frequency range (4 kHz to 8 kHz) [9]. It is a common disorder associated with aging. Meniere's disease causes sensorineural hearing loss in the low frequency range (125 Hz to 1 kHz) [9]. Sensorineural hearing loss refers to problems in the cochlea or the auditory nerve. Most are due to deterioration of the tiny inner or outer hair cells. Its causes maybe due to head injury, certain medical treatments such as chemo- and radiation therapy, genetic predisposition, prolonged exposure to harmful sound (noise) or a sudden brief but intense noise like an explosion very close to the ear. Patients with a sensorineural hearing loss undergo a phenomenon by which sonority grows abruptly from a certain level of signal received; this is known as loudness recruitment [10]. According to [11] conductive hearing loss is caused by any obstruction that prevents sound waves from

reaching the inner ear. Some of the causes of conductive hearing loss can include: a buildup of earwax, an assemblage of fluid in the middle ear or due to middle ear infections. The dynamic range of hearing is measured in terms of sound pressure, in decibels. A normal hearing range extends from approximately 0 dB to 120 dB, where 0 dB is the threshold of hearing and 120 dB is the threshold of pain. Discomfort usually begins to occur around a saturation level of about 90 dB of sound refer to Table 1.

Table 1: Classification of hearing loss [7].

Degree of Hearing loss	Lower limit (dB)	Upper limit (dB)
Normal	-10	15
Slight	16	25
Mild	26	40
Moderate	41	55
Moderately severe	56	70
Severe	71	90
Profound	91	-

The dynamic range compression also known as Automatic Gain Control is usually applied in hearing aids for two reasons:

1. To limit the maximum output signal at high input levels.
2. To compensate for recruitment.

The input/output relationship, typically adopts a shape as that shown in Figure 1. Until the threshold stage, the amplification of sound is linear. When the threshold is overcome, gain increases $1/CR$ dB by each increase of 1dB in the input signal, where CR is the area of compression refer to Figure 1.

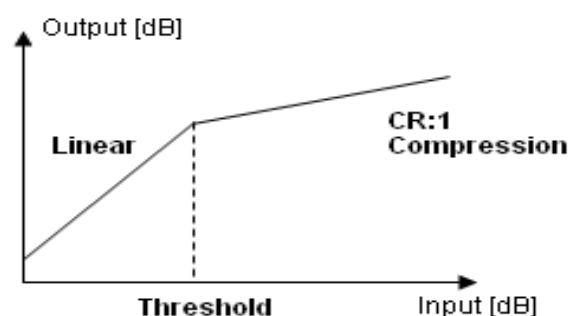

Figure 1: Typical Input/output compression curve.

The compression algorithms should be programmed to be adjusted to each patient's needs. A possible implementation tries to reproduce the operation of internal ciliated cells using a multiband system [12]. Hearing loss compresses the range of hearing, raising the threshold of hearing and typically lowering the threshold of pain. For example, a person with moderate hearing loss would have a Threshold of

Hearing around 40 - 70 dB and a Threshold of Pain around 100 dB.

Hearing aids is designed and implemented based on whether the loss is in one ear (monaural hearing loss) or both the ears (binaural hearing loss). From research, it has been observed that binaural hearing aids provide better spatial estimation of source of sound and greater speech understanding in noisy environment over its counterpart monaural hearing loss. It also reduces the need for amplification because binaural listening provides a boost to the signal.

This research makes use of ATmega328 to process the audio signal input, save battery power and minimize circuit by making use of the internal frequency and ADC of the microcontroller. The paper implements the basic function and circuit of the hearing aid device with the affordable materials to achieve a cheap and portable device. The main components of this system are the audio input unit which consists of the microphone and its pre-amplifier, the microcontroller (ATmega328) which consists of the ADC and the audio signal processing and power saver codes, control codes (noise suppression, amplification controlled codes etc.), feedback system, the DAC, the power amplifier and volume control unit and then the earphones (output).

2. THE DEVICE

The input speech signal will pass through several actions like noise reduction, filter, amplifications, feedback processes and compression before producing an adjusted output speech signal which is audible to the hearing of the impaired person.

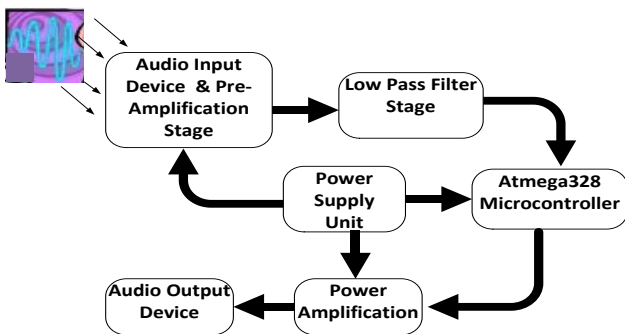

Figure 2: Block Diagram of the Prototype Digital Hearing Aid

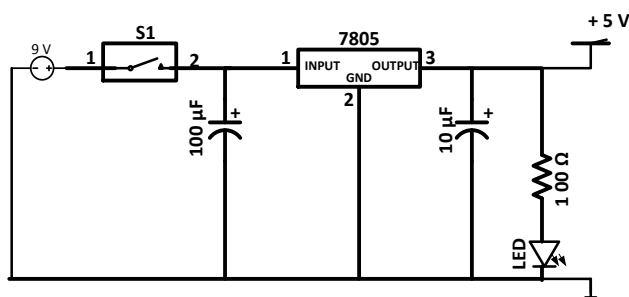

Figure 3: Power Supply

2.1 Power Supply Unit

The power supply to this device is a 9 V_{d.c.} connected across a voltage regulator LM7805 to supply 5 V to the microphone and its pre-amplifier, the microcontroller and the audio power amplifier. The two capacitors of Figure 3 were to filter off harmonics from the power supply.

2.2 Audio Input Device (Microphone)

An electret microphone is a device that uses two conducting plates to capture sound waves and translate them into electrical waves. An electret microphone is an omnidirectional microphone, which means it can capture sound from all directions. This was the device use in this prototype. The electret capsule microphone has a -44dB sensitivity, and has 20 – 20 kHz frequency response. It contains a small vibrating element that will output a few millivolts audio signal peak-to-peak which requires further amplification [13]. From the datasheet, the loading resistance is 2.2KΩ with an operating range of voltage of 1.0V to 10.0V. The connection for microphone is as shown below: For the microphone signal pre-amplification, the collector and emitter voltage feedback bias configuration is used. This is because the combination of both the collector and emitter feedback ensures more stability and less response to thermal changes. The transistor used here is BC547 which is a multipurpose NPN bipolar junction transistor. From the datasheet [14], the following data was gotten:

$$I_C = 5\text{mA}; \beta = 110; V_{BE} = 0.7\text{V}; V_{CE} = 0.5V_{CC} = 2.5\text{V}$$

$$\text{The design supply voltage } V_{CC} = 5\text{V}, V_E = 0.1V_{CC} = 0.25\text{V}$$

$$I_B = \frac{I_C}{\beta} = \frac{5 \times 10^{-3}}{110} = 45\mu\text{A} \tag{1}$$

$$I_E = I_C = 5\text{mA} \tag{2}$$

$$R_E = \frac{V_E}{I_E} = \frac{0.25}{5 \times 10^{-3}} = 50\Omega \tag{3}$$

$$R_C = \frac{V_{CC} - V_{CE} - V_E}{I_C} = \frac{5 - 2.5 - 0.25}{5 \times 10^{-3}} = 450\Omega$$

$$R_B = \frac{V_{CC} - V_{BE} - V_E}{I_B} = \frac{5 - 0.75 - 0.25}{45 \times 10^{-6}} = 90\text{ k}\Omega \tag{4}$$

However, after the calculations, from the available market values,

$$R_E=R_2 = 33\Omega; R_C= R_4= 680\Omega; R_B=R_3=100\text{k}\Omega; R_1 = 2.2\text{ k}\Omega$$

More so, the coupling capacitors were calculated with the following assumptions that the frequency of audio signals is between 20 Hz and 20 kHz

$$C_1 = \frac{1}{2\pi f Z_{in}} = \frac{1}{2\pi \times 20 \times 10^3 \times 8 \times 10^3} \cong 100\text{nF} \tag{5}$$

$$C_2 = \frac{1}{2\pi f Z_{out}} = \frac{1}{2\pi \times 20 \times 680} \cong 0.1\mu\text{F} \tag{6}$$

Figure 4 shows the detailed diagram of audio input and the pre-amplifier stage of the digital hearing aid.

2.3 Low Pass Filter

The analog sound signal is converted into digital realm. The DSP is at the heart of a digital hearing aid manipulating the signal without causing any distortion, so sounds become much clear and speech is easier to hear and understand. The highest frequency that most humans can hear is approximately 20 kHz. Therefore, before the signal enters the A/D converter, it will be low-pass filtered to 20 kHz, which is also our sampling frequency. This will avoid aliasing during sampling. Considering the filter of finite impulse response (FIR) $h_s(n)$ which has transfer function:

$$H_s(z) = \sum_{n=0}^L h_s(n)Z^{-n} \tag{7}$$

This FIR filter is initially approximated by a uniform auto-regressive filter with infinite impulse response (IIR) $h_{AR}(n)$ and transfer function:

$$H_{AR}(z) = \frac{\alpha_o}{1 - \sum_{n=1}^p \alpha_n Z^{-n}} \tag{8}$$

The combination of series of the original FIR filter with transfer function $H_s(z)$ and the inverse of the AR filter is sketched in Figure 5. By this process the noise/undesirable signals are filtered out.

Multi-channel dynamic-range compression otherwise known as digital compressor forms one of the basic part of digital hearing aids. So many factors needed to be considered in the design of such a digital compressor. Among such considerations include frequency resolution, processing group delay, quantization noise, and algorithm complexity. A multi-channel compressor combines a filter bank with compression in each frequency band.

In most implementations, compressors operate independently in each channel but there are some systems where compression gains can be grouped across adjacent bands. The compressor output involves the response of each frequency band to the signal present in that band and even some simple signals might cause complicated responses. The system output is finally produced by adding compressed signals in each band as shown in Figure 6. Through multiband compression, hearing aids separate the input signal out to different frequency bands and each sub-band signal goes through a different channel. Each channel has its own compressor and the amount of compression is different at each frequency depending on the patient's hearing loss or input signal level.

Alternately, noise reduction can be achieved according to [15], by considering two microphones with a distance between them (see Figure 7) and an acoustic plane wave

arriving from a direction θ , considering that the attenuation of the signal along d is negligible, the two signals $m_1(t)$ and $m_2(t)$ at each microphone differ only in a time delay, that is a function of d , θ and c (the speed of sound in air).

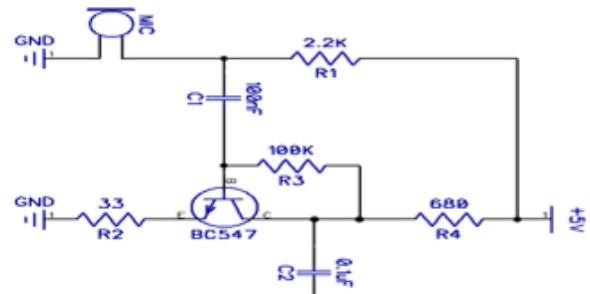

Figure 4: Audio input and pre-amplifier

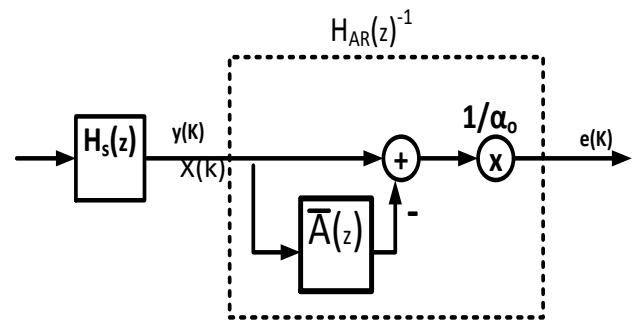

Figure 5: Approximation of a uniform FIR Filter by a uniform AR Filter.

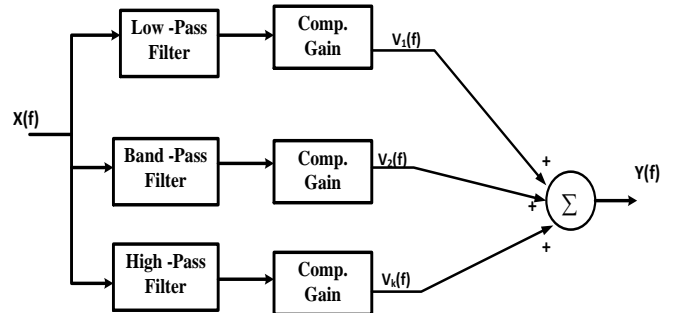

Figure 6 Block diagram of a multi-channel compression system.

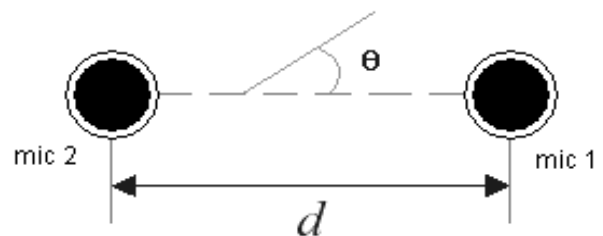

Figure 7: Two omnidirectional microphone array used to get first order patterns [15].

Assuming that $m(t)$ is the signal that a hypothetically third microphone would receive if placed between mic 1 and mic 2, the following equation can be derived:

$$m_1(t) = m\left(t + \frac{d}{2C} \cos \theta\right) ym_2(t)$$

$$= m\left(t - \frac{d}{2C} \cos \theta\right) \quad (9)$$

Let $m_{-1}(t)$ and $m_1(t)$ be the impulse responses of both microphones, and $S_{-1}(t)$ and $S_1(t)$ the impulse responses of the filters to be used in this implementation. The sum signal can be defined as follows (“*” means convolution):

$$S(t) = S_{-1}(t) * m_{-1}(t) * m\left(t - \frac{d}{2C} \cos \theta\right) + S_1(t) * m_1(t) * m\left(t + \frac{d}{2C} \cos \theta\right) \quad (10)$$

Equation (9) can be expressed in the frequency domain as:

$$S(\omega) = M(\omega) \left[S_{-1}(\omega) M_{-1} e^{-j\frac{\omega d}{2C} \cos \theta} + S_1(\omega) M_1(\omega) e^{j\frac{\omega d}{2C} \cos \theta} \right] \quad (11)$$

Finally assuming the microphone sensitivities as the unity, the transfer function of the system is:

$$H(\omega, \theta) = S_{-1} e^{-j\frac{\omega d}{2C} \cos \theta} + S_1 e^{j\frac{\omega d}{2C} \cos \theta} \quad (12)$$

The wave number k is the ratio between the angular frequency ω and c . When the distance between the microphones is negligible compared with the wave length, then $kd \ll 1$ and $H(\omega, \theta)$ can be approximated as:

$$H(\theta)A + B \cos \theta \quad (13)$$

where the coefficients A and B are real.

2.4 Power Amplification

The power amplification of the DAC output is done with a special audio power amplifier- TDA2822M. The processed signal is fed into the input pin 7 over a load of 10kΩ variable resistor which acts as the volume control. This enables the user to tune the volume to his or her desired level. The connections of the audio amplifier as specified by the datasheet [17] is as shown in Figure 8 below.

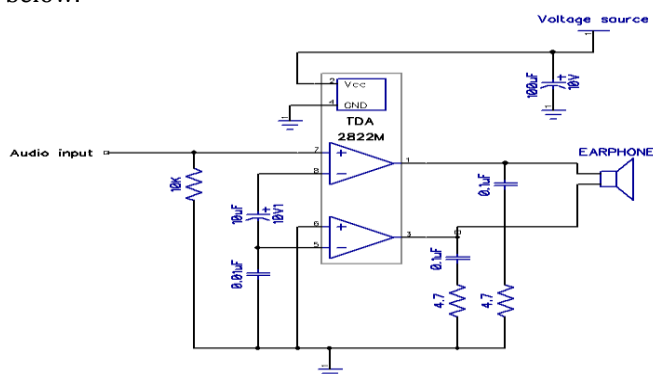

Figure 8: Typical connection of the TDA2822M with single audio input.

A 32Ω or less earphone is recommended for use with this device. This is to ensure low power consumption and a longer battery life of the device. Figure 9 shows the algorithm for the programming into Atmega328 of the Digital microcontroller hearing aid.

3. CIRCUIT DIAGRAM

The overall circuit diagram of the system is as shown in Figure 10. One of the difference from this prototype and many in the market is that when there is no audio input, the system goes on standby to save power and extend battery life.

4. MEASUREMENT OF PROTOTYPE VOLTAGES AND GAIN

The voltages at various points of the system were measured and were used to calculate the gain of the system at various points.

Voltage gain calculations, $Volt\ gain = \frac{V_{o(RMS)}}{V_{in(RMS)}} \quad (14)$

The voltage waveforms measured are sinusoidal waveforms and are peak-to peak measurements, therefore, the RMS voltage is given by:

$$V_{RMS} = \frac{V_{p-p}}{2\sqrt{2}} \quad (15)$$

The following voltage measurements and their corresponding RMS voltages are in the Table 2 below were measured from the prototype device after implementation.

Table 2: Voltages measured at various points of the hearing aid

Voltage Measured	Peak-to-Peak Value (V)	RMS Value (V)
Voltage from the microphone	0.27	0.1
Voltage from pre-amplifier	1.22	0.43
Voltage from DAC	3	1.06
Voltage from power amplifier	2.88	1.02

The Table 3 shows the voltage gain and decibel gain at various stage of the prototype digital hearing aids device.

Table 3: Gain at various points of the hearing aid system

Stage Measured	Voltage Gain	Decibel (dB) Gain
Pre-amplifier Gain	4.3	12.67
DAC Gain	2.47	7.84
Power Amplifier Gain	1.92	6

Overall gain of the system is 27dB

Output power of the system P_o

$$= \frac{(V_{(RMS)})^2}{Load\ impedance\ R_L} \quad (16)$$

$V_{O(RMS)}$ is the output voltage from the power amplifier and the load impedance is the impedance of the earphone. Therefore, the power output of the device is 32.5mW. Figure 11 shows the packaged prototype of the digital hearing aid.



Figure 9: Algorithm used in developing the coding of the microcontroller

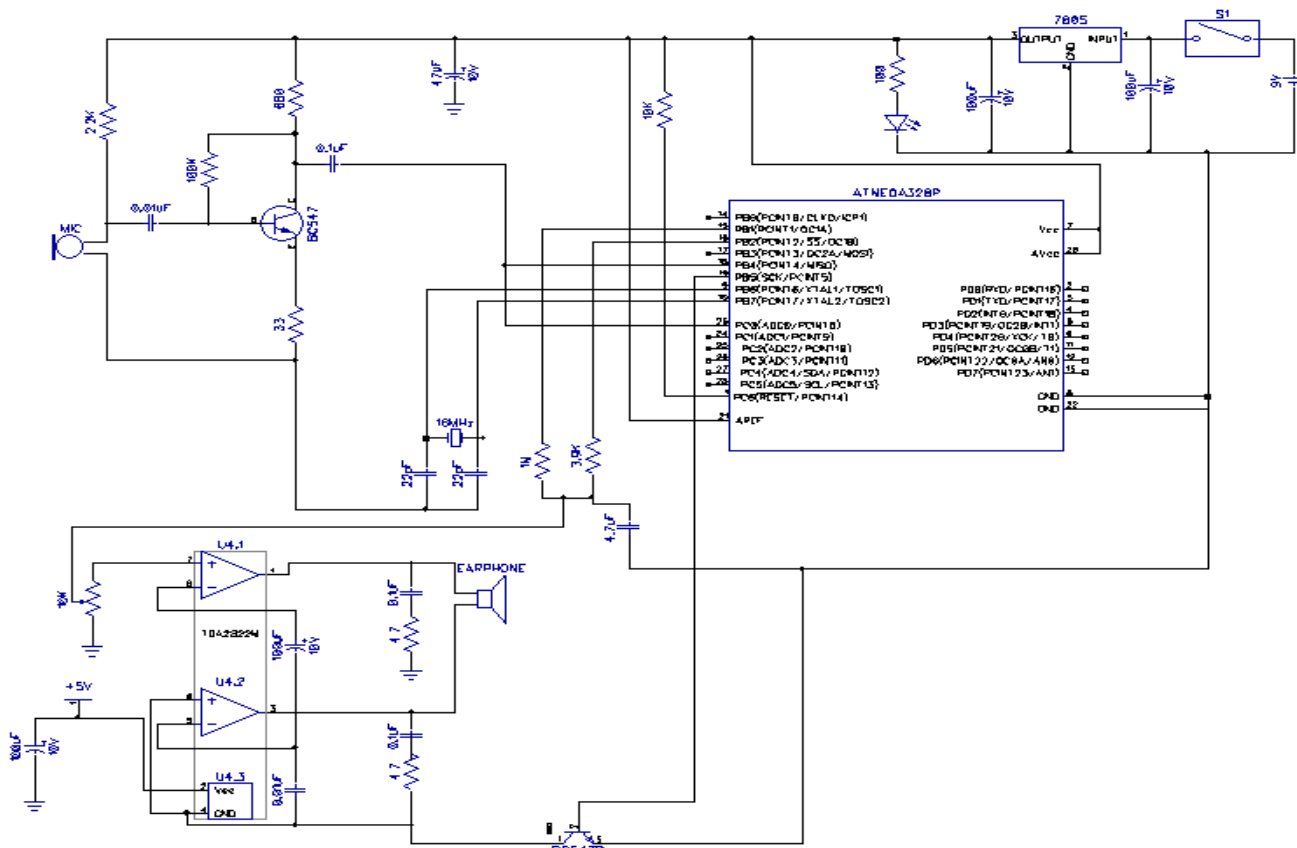

Figure 10: The overall circuit diagram of the hearing aid system

5. CONCLUSION

In conclusion, the circuit for the microcontroller digital audio hearing aid was designed and implemented with an understanding of the function of each component. The microcontroller ATmega328 was used with the added advantage that its internal ADC and DAC were utilized thereby saving the need for external ADC and DAC.

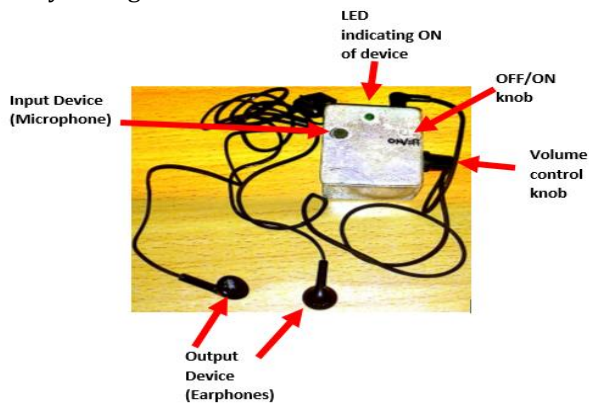

Figure 11: Packaged prototype of the digital hearing aid.

The control codes were written in C language while Mikro C compiler was used to write the codes into ATmega328. The prototype was tested and certified with someone who has hearing impairment and she was able to hear all conversation even in the noisy environment. Having the local content the microcontroller based binaural digital hearing aids for hearing-impaired people developed is relatively cheaper than the one in the market and is also handy.

6. REFERENCES

- [1] "WHO Global Estimates on Prevalence of Hearing Loss", 2012. [Online]. Available: <http://www.who.int/pbd/deafness/estimates/en/>. [Accessed; 14th April 2016]
- [2] R. Grewal and J. Irwin, "Innovative Ways Hearing Aids can be Improved for Clinical Use", *Scott Uni Med*, Vol. 1, no.7, 2012.
- [3] I. V. Kundsén et al, "Factors Influencing Help Seeking, Hearing Aid Uptake, Hearing Aid Use and Satisfaction with Hearing Aids: A Review of the Literature", *Trends in Amplification*, vol. 14, no.3, pp. 127 – 154, 2010.
- [4] T. A. Ricketts, "Digital Hearing Aids: Current State of Art", American Speech, Language and Hearing Association, 2010.
- [5] J. Kerckhoff, J. Listenberger and M. Valente, "Advances in Hearing Aid Technology", *Contemporary Issues in Communication Science and Disorders*, p. 35, 2008.
- [6] Ratnani Nikita and Sharma Manisha, "Implementation of Digital Hearing and Speech Aid using MATLAB: A Survey", *Research Journal of Engineering Sciences*, vol. 5(6), pp.18-20, June (2016).
- [7] Othman O. Khalifa, M.H. Makhtar and M.S. Baharom, "Hearing Aids System", *International Journal of Computing & Information Sciences*, vol.2, No.1, April 2004.
- [8] <http://www.britannica.com/EBchecked/topic/175622/human-ear>
- [9] VivekDalal, Aayush Bansal, Pratik Bhandari, UnmeshBarhate. "Software Simulation of DSP algorithms implemented in Binaural Hearing Aids", *International Journal of Engineering Research and Applications (IJERA)* ISSN: 2248-9622 www.ijera.com Vol. 3, Issue 2, March -April 2013, pp.1224-1229.
- [10] GarcíaBarrese, Marcelo F. Bontempi, Pedro J. Wundes, Pablo E. Boim, Diego J. F. "Development of a digital hearing aid with advanced processing algorithms", 8th WSEAS *International Conference on Signal, Speech and Image Processing (SSIP '08)* Santander, Cantabria, Spain, September 23-25, 2008.
- [11] Navdeep Kaur&Hardeep Singh Ryait, "Study of Digital Hearing Aid Using Frequency Shaping Function", *International Journal of Engineering Research & Technology (IJERT)* vol. 2 Issue 5, May – 2013.
- [12] Edwards, B. W., Struck, C. J., Dharan, P., Hou, Z., "New Digital Processor for Hearing Loss Compensation based on the Auditory System". *Hear Jour.* 51(8): 38-49, 1998.
- [13] Electret Microphone – 20 Hz – 20 kHz omnidirectional" Adafruit, 2015, [Online]. Available: <http://www.adafruit.com/product/1064>. [Accessed. 20th March 2016].
- [14] *BC547 datasheet*, Fairchild Semiconductor Corporation, 2002.