



# ENERGY CHARACTERISTICS OF ETHANOL-DIESEL MIX FOR AUTOMOTIVE USE

W. A. Akpan<sup>1</sup>, A. Offiong<sup>2</sup> and E. G. Ikrang<sup>3,\*</sup>

<sup>1,2</sup> DEPARTMENT OF MECHANICAL ENGINEERING, UNIVERSITY OF UYO, UYO. AKWA IBOM STATE. NIGERIA

<sup>3</sup> DEPARTMENT OF AGRICULTURAL AND FOOD ENGINEERING, UNIVERSITY OF UYO, UYO. AKWA IBOM STATE. NIGERIA

*Email addresses:*<sup>1</sup> [akpanasukwo@yahoo.com](mailto:akpanasukwo@yahoo.com),<sup>2</sup> [irdimangement@yahoo.com](mailto:irdimangement@yahoo.com),<sup>3</sup> [elijahikrang@yahoo.com](mailto:elijahikrang@yahoo.com)

## ABSTRACT

*This research work investigates the power output obtained from ethanol- diesel mix from a diesel engine. A 1% to 5% by volume of 99.6% ethanol was mixed with diesel fuel. A 500ml of each mix was used to power a 9.545kW diesel engine and the engine speed, torque, power and specific fuel consumption (sfc) were determined. Performance test indicates a 4.2% drop in power output at a 5% ethanol addition to diesel and an increase in specific fuel consumption by 1.2%. Five volumetric dilution were made resulting in the following trend: flash point (64°C, 62.6°C, 61.1°C, 59°C, 58.1°C, 56.8°), kinematic viscosity (4.212 mm<sup>2</sup>/s, 3.773mm<sup>2</sup>/s, 3.533 mm<sup>2</sup>/s, 3.207 mm<sup>2</sup>/s, 3.016 mm<sup>2</sup>/s, 2.965 mm<sup>2</sup>/s); dynamic viscosity (3.5 MPa.s, 3.1 MPa.s, 2.9 MPa.s, 2.6 MPa.s, 2.4 MPa.s, 2.3 MPa.s) and density (0.8310, 0.82158, 0.8208, 0.8108, 0.7958, 0.7758); Shaft speed (1423rpm, 1352rpm, 1286rpm, 1193rpm, 1135rpm, 1052rpm); torque (64Nm, 67Nm, 70Nm, 75Nm, 78Nm, 83Nm); Power output (9.545kW, 9.487kW, 9.428kW, 9.371kW, 9.272kW, 9.142kW) with increased ethanol addition. This shows that the energy content of ethanol-diesel mix is lower than that of diesel fuel leading to a low power output compared to diesel fuel.*

*Keywords:* Ethanol, diesel, fuel mix, energy characteristics, combustion.

## 1. INTRODUCTION

Ethanol is increasingly used as bio-fuel because of the greenhouse effect caused by fossil fuel. Cassava is known as one of the richest fermentable substances for the production of crude alcohol/ethanol, with dry chips containing up to 80% of fermentable substances -starch and sugars [1]. Bio-ethanol is generally produced by the fermentation of sugar, cellulose or converted starch. The production process of ethanol include-hydrolysis, cooling and filtration, neutralization, fermentation and distillation where ethanol is distils off at a temperature of 78.5°C [2]. The product is dehydrated to obtain anhydrous ethanol of about 99.6% ethanol. This is the form that is suitable for mix with diesel fuel.

Ethanol is a highly flammable liquid. It is a volatile and colourless liquid that has a slight odour. It burns with a smokeless blue flame. Ethanol reduces harmful emissions from compression ignition engines of sulphur-dioxide, oxides of nitrogen and particulate

emissions Ethanol fuel is anhydrous ethanol with high concentration suitable for industrial uses. It is most often used as a motor fuel, mainly as a bio-fuel additive for diesel or gasoline [3], [4]. The physical properties of ethanol is provided by [5].

Diesel fuel in general is a liquid fuel used in diesel engines. The most common is the specific fractional distillate of petroleum fuel oil, but alternates that are not derived from petroleum, such as biodiesel, biomass to liquid (BTL) or gas to liquid (GTL) diesel, are increasingly being developed and adopted for use in powering diesel engine. To distinguish these types, petroleum derived diesel is increasingly called petrodiesel. Petroleum diesel, or fossil diesel is produced from the fractional distillation of crude oil between 200°C and 350°C at atmospheric pressure, resulting in a mixture of carbon chain that typically contain between 8 and 21 carbon atoms per molecules [5].

\*Corresponding author, Tel: +234-802-569-3683

No. 1-Diesel fuel is a lighter, kerosene-based diesel fuel having a lower viscosity, density, cloud point and pour point than No. 2-D diesel fuel. It is used for extreme low temperature operation and is commonly blended with No.2 -D diesel fuel to improve the No. 2-D low temperature operation [5]. No. 2-Diesel fuel is standard grade of diesel fuel used in heavy trucks, diesel cars and marine applications. [5]. Diesel fuel specifications and test methods in the US is provided by (ASTM), [5].

Ethanol-diesel fuel or e-diesel is a blend of standard diesel (EN 590) with percentage volume by volume of ethanol mixed with diesel. Emulsifiers improve the water tolerance of ethanol diesel blends. An emulsifier is required even at 5% ethanol, for the fuel to remain a single phase in the presence of water. In addition, lubricity, detergency, and low temperature properties can be achieved by the use of emulsifiers [6], [7], [8], [9]. In the presence of a proprietary additive, standard diesel can be blended with 5% to 25% by volume ethanol. Ethanol-diesel blended fuels are rated according to the percentage of ethanol present in the blend. Without additives, up to 5% anhydrous ethanol can be blended to diesel fuel.[10]. Each 10% volume ethanol added to diesel fuel, result in a 7.1-unit reduction in cetane number of the resulting blend [11]. The energy content of ethanol-diesel decreases around 2% for each 5% of ethanol by volume added. [12]. However, detailed power output experimental results of energy content of such mix are not readily available in literature.

E-Diesel is an attractive option to fleet operators because it offers an economical solution to bring fleet emissions within mandated levels without expensive hardware retrofits, major modifications to refuel or storage infrastructure or substantial retraining of maintenance staff [13]. The various blends used in this research work were: E1-D (Blend 1% ethanol 99% diesel) E2-D (Blend 2%ethanol 98% diesel) E3-D (Blend 3%ethanol 97% diesel) E4-D (Blend 4%ethanol 96% diesel) and E5-D (Blend 5%ethanol 95% diesel) by volume

Studies on the use of ethanol in diesel engine were directed at reducing the smoke and particulate matter in the exhaust gas. Inclusion of ethanol in diesel fuel results in different physical -chemical changes in diesel fuel properties especially reduction in cetane number, viscosity and heating value. From 1990s, the use of ethanol blended diesel fuels has been on the increase in heavy duty and light duty diesel engines in order to reduce their emission characteristics.

Ethanol being a polar molecule, its solubility in diesel in diesel is prone to be affected by temperature and water content hence high percentage inclusion of ethanol in diesel is difficult. Some of the physical and chemical properties of ethanol -diesel blend that affect its use on a diesel engine are the stability, density, viscosity, surface tension, specific heat, heat value and cetane number which have great effect on injection ,atomization, ignition and combustion properties. They also affect cold start of the engine, power, fuel consumption and emission characteristics of such engine. According [13], 10% addition of ethanol by volume to diesel fuel results in a 7.1 unit reduction in cetane number of the resulting blend, It should be noted that ethanol has a low cetane number (about 8) so that once added to diesel fuel reduces the resulting blend cetane number significantly. The use of ethanol- diesel blends has its attendants limitations .These are lower lubricity and viscosity, cetane number and ignition quality, and higher volatility which may increase unburnt hydrocarbon emissions, lower miscibility which may cause phase separation with catastrophic outcome [14]. In spite of all these difficulties, using cetane enhancers and co solvents additives help to increase their potential of the various blends as a promising fuel for diesel engines. In trying to experiment some ethanol -diesel blend at temperatures above 30<sup>0</sup> C in diesel engine where phase separation is not likely to occur at that temperature, the objective listed shall be accomplish. The objective of this research is to determine the combustion characteristics of ethanol-diesel fuel mix, its energy content and also its effect on compression ignition engine performance.

## 2. METHODOLOGY

Ethanol was obtained from starch by hydrolysis, neutralization, fermentation, distillation and by dehydration. Freshly harvested cassava roots were weighed, using the digital weighing balance.

The roots were peeled and reweighed. The cassava was washed to remove dirt and solid contaminants. The cassava was grated using a grater and the resulting mash weighed. 3 liters (3000ml) of water was added to the cassava mash and mixed thoroughly, and then Muslin cloth was used to filter out the fibrous cassava leaving the soluble starch water. The soluble starch was weighed and the specific gravity value taken by weighing a pycnometer (density bottle). The pycnometer was filled with distilled water and

reweighed, and then filled with the soluble starch and reweighed again. The specific gravity was calculated.

The volume of the starch extract was measured and the pH reading was taken using the digital pH meter. 100ml measuring cylinder was used to measure 40ml of concentrated tetraoxosulphate (VI) acid ( $H_2SO_4$ ), the acid was added to the starch extract and the pH reading of the solution was taken after acidification. Using a silver coated pot, the acidified solution was heated on an electric stove and stirred continuously using a glass rod. The sample was withdrawn using a beaker and tested for starch using iodine solution. The acidified extract was continuously stirred to avoid getting gelled. The extract was boiled for 186 minutes. The sample was allowed to cool to  $32^\circ C$ , and then 0.5M solution of  $Na_2CO_3$  was prepared by dissolving 53g of the base in 1 litre of distilled water. The base solution was added to the sample until the pH value of the sample increased to 5.7.

The neutralized sample was weighed. Baker's yeast, *saccharomyces cerevisiae* was inoculated by preparing a fermentable sugar solution by dissolving 15.94g of sugar in 100ml of warm water at  $42^\circ C$  and then 15g of the yeast was added to the fermentable sugar solution and the yeast was left to grow for 20 minutes. The standardized inoculum was added to the neutralized sample and stirred. The temperature, pH and specific gravity values of the sample were taken for 0hrs, 48hrs and 72hrs of fermentation. The percentage of ethanol content of the sample for the stated period was determined using an Alcozyzer.

The fermented sample was filtered. A 100ml distillation flask was filled with the fermented sample, placed on an electric heater, and connected to a clear-fit distillation apparatus with a thermometer inserted into it. Ethanol was distilled off at a temperature of  $78.5^\circ C$ .

The pH of the sample withdrawn was determined using the method of Association of Official Analytical Chemists (AOAC): 25 ml of the sample was measured at  $28^\circ C$  into a beaker. The probe of the meter was dipped in distilled water, and then dipped in the sample. The reading was taken and recorded after which the pH meter was switched off and the probe rinsed with distilled water. Triplicate values were obtained and the mean taken as the pH Value.

The sample was filtered and 50ml of the sample was fed into the tube and sucked by the machine for analysis and the percentage content of ethanol displayed after 2 minutes.

The process yielded 99.6% of ethanol. Laboratory tests on the physical properties such as density, dynamic and kinematic viscosity, flash point, of the product were determined. The density of the sample was determined in accordance with ASTM D4042-11 Standard Test method for density. The 10ml measuring cylinder was washed, dried and left to cool under room temperature. The sample was poured into the cylinder until it reached the 10ml mark. The cylinder was weighed and the reading of the digital density meter taken. Standard test method for dynamic viscosity of liquids by Vann VG Viscometer (also conforming to the EN ISO 3104 test method) was used. Five constant temperature bath tubes were washed and dried. The tubes were labeled E-1D, E-2D, E-3D, E-4D and E-5D. The ethanol-diesel samples were stirred using the magnetic stirrer, each ethanol-diesel blend sample was poured into the corresponding labeled tube and was conditioned to  $20^\circ C$  using the constant temperature bath. E-5D (5% ethanol, 95% Diesel) was poured into the Vann VG Viscometer tube and the viscometer was set at low speed with torque of 300rpm. The dynamic viscosity reading (in centipoise) was taken for E-5D (blend 5% ethanol, 95% diesel blend). The procedures were repeated for E-4D, E-2D, E-1D and 100% Diesel and the reading for the dynamic viscosity taken (in centipoise). The value of the Kinematic viscosity was obtained by dividing the dynamic viscosity by its density.

The procedure described in ASTM D93 Standard Test Method (also conforming to the EN ISO 2719 test method) for Determining Flash Point for Liquid Fuels was used. The ethanol-diesel blends were mixed and stirred using the magnetic stirrer (E-5D, E-4D, E-3D, E-2D, E-1D), 100% Diesel). Each of the fuel blend sample was poured into the cup of the Pensky-Martens flash point water and the lowest temperature at which the application of the ignition source causes the vapor above the liquid to ignite was taken.

Diesel was purchased from NNPC Mega station in Akwa Ibom State. The various blends of these two products were made and the laboratory characteristics recorded. The total volume of each blend was 500ml. The actual performance tests of the mixture were done using a 9.9kW Sifang Chinese (maximum rating) diesel generator (3 years old and has an efficiency of about 96%). After a run of each mix, the diesel filter was removed, emptied and flushed with a new fuel mix. The mixture was supplied to the generator through a graduated scale. The speed and torque of the output shaft of each blend were

measured using a tachometer. A diagrammatic representation the experimental set up is shown in Fig. 1

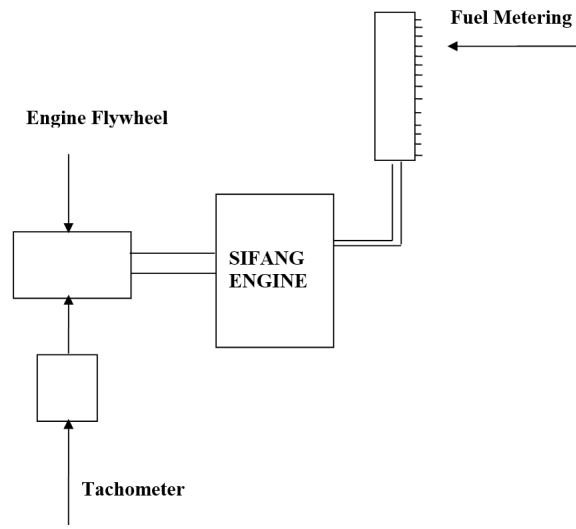

Figure 1: A diagrammatic test set up of engine performance with the fuel mix

### 3. RESULTS AND DISCUSSION

The laboratory properties of ethanol-diesel blends ethanol fuel and diesel fuel (No. 2-Diesel fuel) -(E1-D, E2-D, E3-D, E4-D, E5-D), are tabulated in the Tables 1 and 2 respectively. From Table 1, it is observed that the flash point of the blend is lower than that of diesel. The fuel economy of the blend is presented in Table 2. The diesel fuel has a better fuel economy than the blend. At a blend of 5% ethanol and 95% diesel by volume the fuel consumption is increased by 1.2%. The power output of the diesel blend also decreases. With

5% ethanol and 95% diesel mix the drop in power output is 4.2% as presented in Table 3. However, the energy characteristics of diesel decreases as the ratio of the mix increases from 9.545kW to 9.487kW; to 9.428kW; to 9.371kW, to 9.272kW; and to 9.142kW) per 1% addition of alcohol by volume. The reduction is 0.065kW, 0.052kW, 0.057kW, 0.099kW and 0.43kW. The reduction in energy characteristics of the mix becomes significant as the volume of ethanol is increased by volume. A drop by 0.6% 0.55%, 0.6%, 1% and 4.2% respectively are obtained per 1% of ethanol added by volume. These results show that the energy value of ethanol-diesel mix is lower than that of diesel fuel. In terms of power requirement the addition is not beneficial except where diesel engine emission environment regulation is to be complied with. The mix will however promote the ethanol production and stimulate the economy where such regulations are applied.

### 4. CONCLUSIONS/RECOMMENDATIONS

There is a drop in power output when ethanol is mixed with diesel and an increase in fuel consumption. Ethanol -diesel mix burns faster than diesel. The energy content of ethanol -diesel mix is less than that of diesel fuel. Ethanol- diesel fuel mix has a limited mixed ratio after which there is no engine firing and shaft power output. A research work on ethanol-gasoline fuel mix is hereby recommended.

Table 1: Measured characteristics of fuel mix samples

Fuel Sample	Density at 20°C (kg/l)	Dynamic viscosity at 20°C (MPa.s)	Kinematic Viscosity at 20°C (mm <sup>2</sup> /s)	Flash Point (°C)
100% Ethanol	0.7990	0.6	0.750	14.0
100% Diesel	0.8310	3.5	4.212	64.
E1-D	0.82158	3.1	3.773	62.6
E2-D	0.8208	2.9	3.533	61.1
E3-D	0.8108	2.6	3.207	59.0
E4-D	0.7958	2.4	3.016	58.1
E5-D	0.7758	2.3	2.965	56.8

Table 2: Fuel blend consumption characteristics

Fuel blend	Volume(ml)	Mass(g)	Time to consume 500 ml $\times 10^3$ (s)	Fuel consumption $\times 10^3$ (g/s)
100% Diesel	500	415.5	2.4	1.731
E1-D	500	410.8	2.352	1.747
E2-D	500	410.4	2.280	1.800
E3-D	500	408.4	2.1184	1.856
E4-D	500	392.9	2.136	1.863
E5-D	500	387.9	2.064	1.879

Table 3: Fuel blend power output and specific fuel consumption

Fuel blend	Shaft speed (rpm)	Torque(N-m)	Power(Kw)	Fuel consumption $\times 10^{-4}$ (kg/s)	Specific fuel consumption $\times 10^{-3}$ (Kw/hr)
100% Diesel	1424	64	9.545	1.731	54.4050
E1-D	1352	67	9.487	1.747	55.2450
E2-D	1286	70	9.428	1.800	57.2760
E3-D	1193	75	9.371	1.856	59.4180
E4-D	1135	78	9.272	1.863	60.2790
E5-D	1052	83	9.145	1.879	61.6410

## 5. REFERENCES

- [1] Kuiper, L., Ekmekci, B., Hamelinck, C., Hettinga, W., Meyer, S. and Koop, K. (2007) Bio-Ethanol from Cassava, Ecofys, Netherlands.
- [2] Sriroth, K., Wanlapatit, S. and Piyachomkwan, K. (2011) Cassava Bioethanol Cassava and Starch Technology Research Report, TC3905, National Center for Genetic Engineering and Biotechnology (BIOTEC), Thailand.
- [3] Bailey, B. K. (2010) *Handbook on Bioethanol: Performance of Ethanol as a transportation Fuel*, Biofuels Information Center, New York.
- [4] Larsen, U., Johansen, T. and Schramm, J. (2009) Ethanol as a Fuel for Road Transportation, Advanced Motor Fuels Main Report, 2009- EFP06, Danish Energy Authority, Denmark.
- [5] Bacha, J., Freel, J., Gibbs, A. and Hemighaus, G. (2007) *Diesel Fuels Technical Review*, Chevron.
- [6] Chacartegui, C. M., Lopez, J. E., Alfonso, F. S., Aakko, P., Hamelinck, C., Vossen, G. V. and Kattenwinkel, H. (2007) Blending Ethanol in Diesel. *Bioscopes*. 80, 8 – 103.
- [7] Jatin T. J. and Pravin P. R. (2012) Recent Trends on Ethanol-Diesel Fuel Blends Used in Compression Ignition Engines. *International Journal of Advanced Engineering Research and Studies*. 1 (2249-8974), 51-54.
- [8] Al-Hassan, M., Mujafet, H. and Al-shannag, M. (2009) An Experimental Study on the Solubility of a Diesel-Ethanol Blend and on the Performance of a Diesel Engine Fueled with Diesel-Biodiesel - Ethanol Blends. *Jordan Journal of Mechanical and Industrial Engineering* 6 (1995 - 6665), 147 – 153.
- [9] Fanick, E. R. (2004) Fuel and Fuel Additive Registration Testing of Ethanol-Diesel Blend for O<sub>2</sub> Diesel, NREL Subcontractor Report, NREL/SR-540-35334, National Renewable
- [10] Gerdes, N. K., Shehata, M. S. and Razek, F. Y. (2001) Miscibility of Ethanol in Diesel Fuels. *SAE Information Report*, 2001-04 3895, Society of Automotive Engineers, New York.
- [11] Corkwell, K.C and Jackson M.M. (2002) "Lubricity and Injector Pump West Issues with E-Diesel Rule Blends. *SAE Information Report*, 2002-01 6791, Society of Automotive Engineers, New York.
- [12] McCormick R. L. and Parish R. (2004) Technical Barriers to the Use of Ethanol in Diesel Fuel, *NREL Milestone Report*, NREL/MP-540-32674, National Renewable Energy Laboratory, New York.
- [13] Li D H, Zhen X Lu, W Zhang and J Yang (2005) Physico chemical properties of ethanol diesel blend fuel and its effect on performance and emission of diesel engines, *Renewable Energy* V 30 no6 pp 961- 976
- [14] Stage de Caro P, Moulougui Z, Vaililuigom G, Berge Jch (2001) Interest of Combining an additive with diesel -ethanol blends for use in diesel engines, *Fuel* 80 565-74
- [15] Ahmed I. (2001) Oxygenated Diesel: Emissions and Performance Characteristics of Ethanol-Diesel Blends in CI Engines, *SAE Information Report*, 2001-01 2475, Society of Automotive Engineers, New York.