

PERFORMANCE ANALYSIS OF A MODIFIED PNEUMATIC SEPARATOR FOR COWPEAS

O. E. Similowo, O. T. Araromi and O. O. Adesanya
*Department of Mechanical Engineering,
University of Ibadan, Nigeria.*

ABSTRACT

In this work, modifications have been done on a prototype pneumatic separator to improve its efficiency. The effects of the modifications were studied by carrying out performance test analyses on the two blowers and reciprocating sieve mechanism which make up the critical components of the separating machine. The variations in the feed weights of the sieve were analysed to determine the best and most effective screening process. Also, the best and least tilt angles of the blowers were considered to determine the best and least blowing processes to clean the beans. The results of analyses showed that for a feed weight of 3.0kg the sieving process attained its best efficiency of 50.2%. The maximum efficiency of 79.2% for the first pneumatic separator was obtained at a tilt angle of 30°, while a maximum of 77.7% was obtained for the second separator at 0° tilt angle. An overall efficiency of 77% was estimated for the modified pneumatic separator.

Keywords: - *Pneumatic Separator; Design-Modifications; Performance-Analyses*

INTRODUCTION

The tedium and stress involved in the manual processing and cleaning of large amount of grains prior to consumption within a given time limit has made the continual design and performance studies of alternative mechanical methods necessary. Subsequently, many works are been carried out on the removal of unwanted materials.

Earlier works include those of Sullivan (1970) and Lawton (1980) who studied vibrating screens and gravity tables respectively as means

of separating grains from impurities. Also, Koya and Adekoya (1994) looked critically at some physical and aerodynamic properties relevant in de-stoning some grains. The outcome of the work and the principle of terminal velocity have been applied to the design of the separators carried out in this present work. However, in more recent times, (Dabor, unpublished); (Aigbokchai and Awomolo, unpublished) produced the first design of the pneumatic separator discussed in this paper. Other modifications were further done by (Araromi and Adesanya, unpublished).

The Horizontal inertia-drive vibrating screen and the chaff aspirator are examples of post-harvest machines operating on the principles of vibration and gravity mentioned earlier developed over the years. However in this work a specified separator for cowpeas only to be used after the application of post-harvest separators prior to final home consumption on a larger scale has been developed. The modifications of the prototype carried out in this work aims at improving its efficiency. They include alteration of frame-work; inclusion of screening mechanisms; change of less efficient parts and proper surface finish to enhance attractiveness and value.

The performance analyses done in this work is an improvement over the previous due to the modifications made and more so the inclusion of the screening test which was not carried out in the previous works. Hence two major tests were carried out in the present performance analyses namely; the screen test and the pneumatic tests. Improvement and continuous work on the separators will eventually produce the optimum cleaning required for cowpea before home consumption

The overall objective of this work is to further reduce the boredom and tedium associated with large scale cleaning of cowpeas prior to final consumption. Specifically, it is to improve the efficiency of an existing pneumatic separator (Simolowo *et al.*, 2004) by (i) introducing some design modifications on the existing prototype machine (ii) carrying out performance analyses on the modified pneumatic separator.

DESCRIPTION AND FUNCTIONS OF MODIFIED MACHINE ELEMENTS

The description of the prototype machine had earlier been presented in the preliminary works (Simolowo *et al.*, 2004). The newly added parts are described with reference to the isometric view of the newly modified separating machine shown in Fig.1.

The modified frame that was designed with dimensions 800mm by 550mm and height of 1320mm accommodates the shaker sieve, inclined plate and shaker mechanism. The cam converts rotary motion from pulley to translation motion in the sieve. It was constructed graphically to precision using mild steel flat bar of length 340mm, width 17mm and thickness 30mm. The shaker-sieve serves as the flat face follower for the cam. The function of the shaker sieve is to receive the mix, agitate it and allow its passage to the inclined plate via its holes. It was constructed with mild steel sheet gauge 16mm with dimensions 636mm by 430mm by 70mm and consists of 8mm drilled holes.

The included return spring returns the sieve after the required amplitude is reached by the rise of the cam. It was welded to the frame and has dimensions of 50mm x 30mm x 2mm. The inclined plate is 646mm x 430mm and is inclined at 8° to allow smooth rolling down of the cowpeas and ensure that the mix fall in front of the line of air flow. The grain collector is a rectangular tray made from mild steel sheet gauge 16mm. It is 70mm x 310mm x 160mm and demarcated to separate the stones from mixing with the cleaned beans. The pulley incorporated into this modification is employed both for transmitting motion to the shaft in the shaker mechanism as well as reducing the speed of the cam. It was fabricated by coiling a mild steel rod 620mm into circular shape and grooved to a depth 15mm. The pulley diameter is 350mm and 20mm thick to accommodate the fan belt.

DESIGN OF MODIFIED MACHINE COMPONENTS

In line with the earlier mentioned objectives of modifying an existing pneumatic cowpea separator as shown in Fig. 1, basic design principles are given only for modified parts in this section because considerations have been given to other existing parts in the prototype design of the equipment (Simolowo *et al.*, 2004).

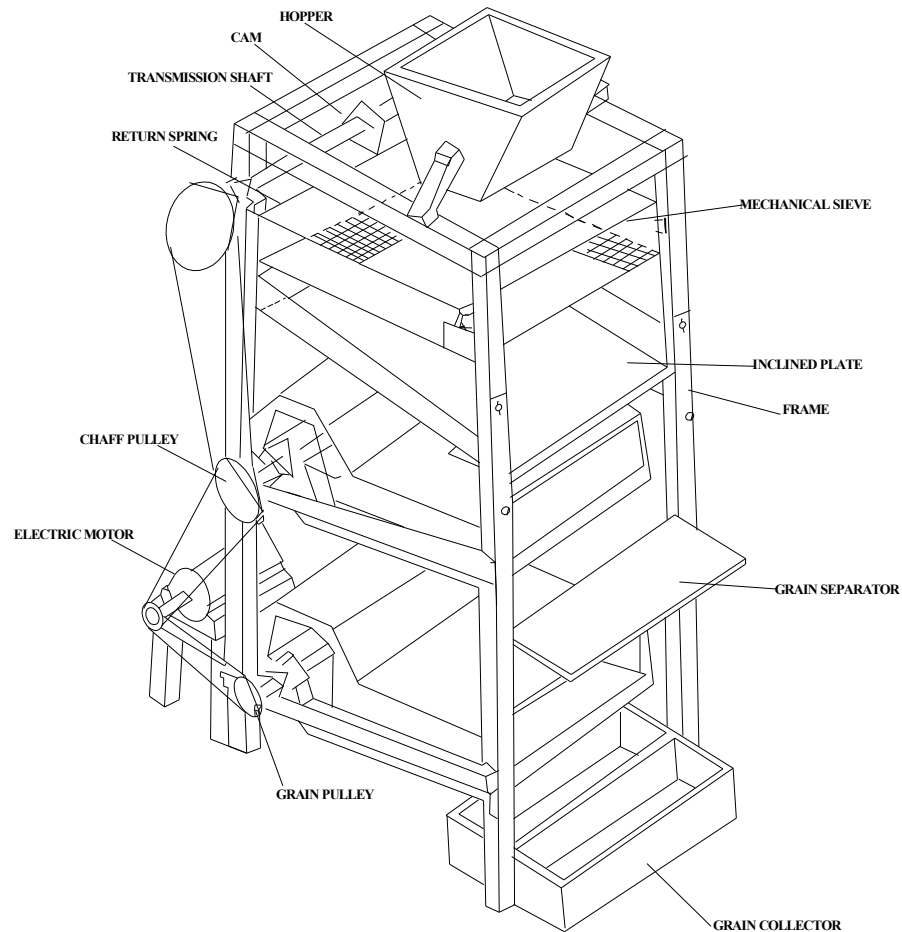

Fig. 1: THE ISOMETRIC VIEW OF MODIFIED BEAN / PARTICLE SEPARATING MACHINE

Design of Cam Follower Mechanisms

In the design of the complete cam/follower shaker mechanism introduced into the separator, five major sub-components are considered, namely; the cam profile, follower face width, angle of repose of inclined plane, return spring and shaker mechanism.

Cam Profile: - The following design criteria were used in the graphical design of the cam

profile shown in figure 3: (i) the maximum displacement of the cam in contact with the shaker was taken as 30mm for optimum agitation, (ii) a two-motion (Rise-Fall) profile was employed for smooth shaking of the sieve and (iii) the diameter of the offset hole in the cam was taken as 25mm to make a tight fitting for the driver shaft

Face Width of Follower: - This represents the height of the shaker inclined plate in contact with

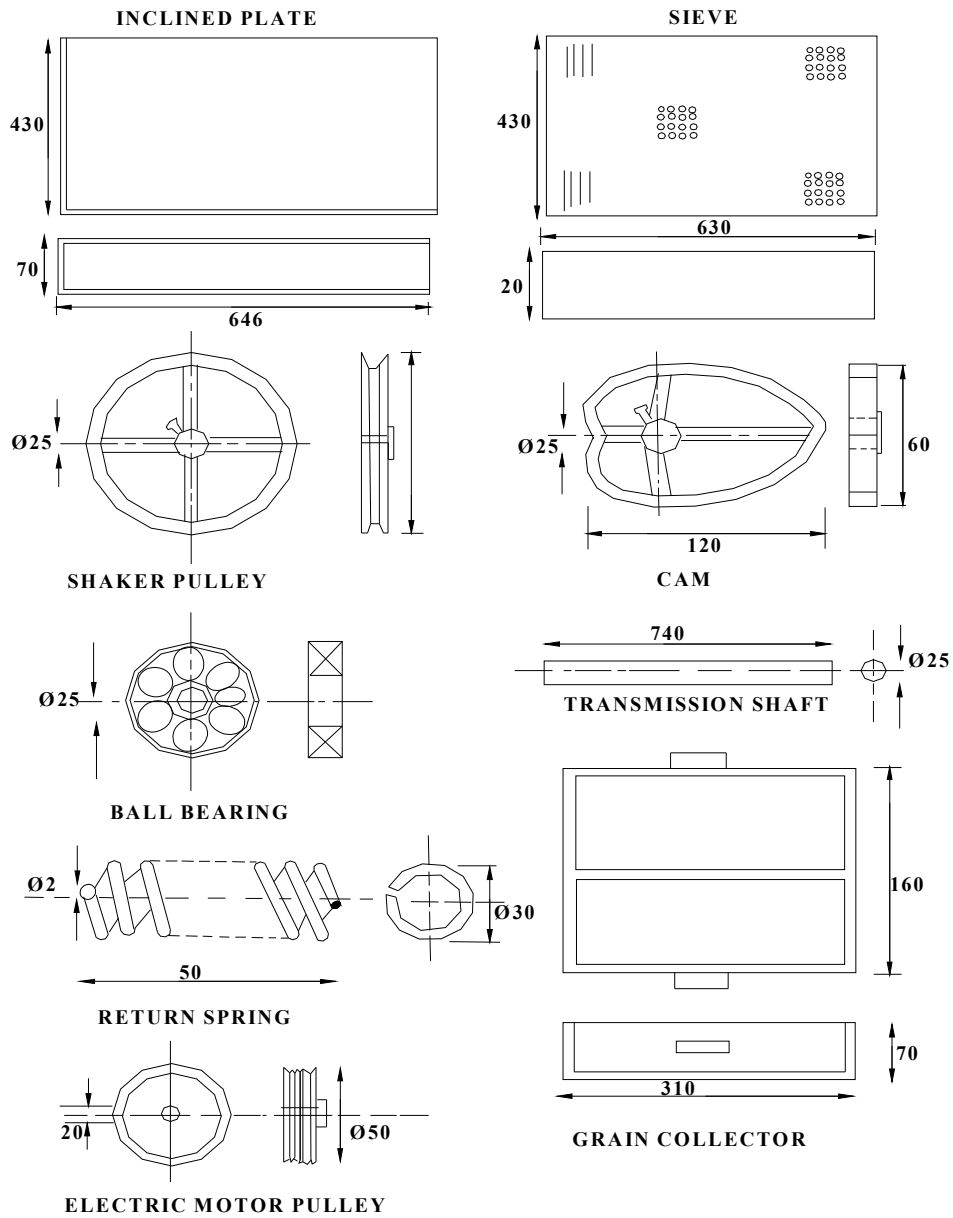

Fig. 2: Components Parts of the Modifications Incorporated

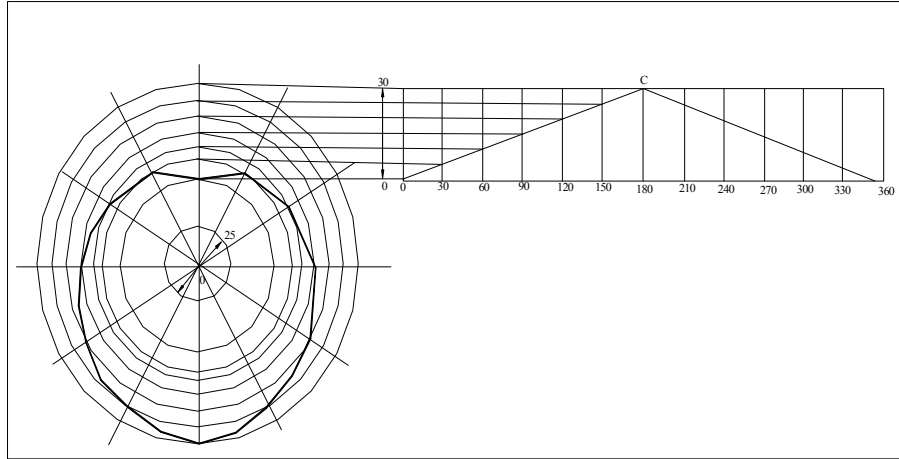

Fig. 3: GRAPHICAL DESIGN OF CAM PROFILE

the cam. It was determined based on three critical considerations: (i) maximum dimension across the oval shaped cam after its design measured to be 60mm (figure 3), (ii) determined height for the shaker to accommodate enough cowpeas. Having known the shaker length (0.636m), width (0.43m) and optimum volume of grain 0.02m³ this height was determined, (iii) the required Face width must be equal to or greater than values obtained in (i) and (ii) to maintain constant contact between the inclined shaker plate and cam without the grains falling off.

Return Spring Strength: - This is determined by considering the shear stress (τ); Store energy (U_s) and maximum allowable stress ($S_{s \max}$). Equations (1), (4), (6) are used to determine these three parameters respectively (Allen et al, 2002). Where F is axial load on spring; K is Wahl factor given as equation (2); D is mean diameter of spring coil; d is diameter of wire; C is the spring index given as equation (3); y the axial deflection is given as (5); G is the modulus of rigidity and n is the number of spring turns

$$\tau = \frac{K8FD}{\pi d^3} \dots\dots\dots (1)$$

$$k = \frac{4C-1}{4C-4} + \frac{0.615}{C} \dots\dots\dots (2)$$

$$C = \frac{D}{d} \dots\dots\dots (3)$$

$$U_s = \frac{1}{2} Fy \dots\dots\dots (4)$$

$$y = \frac{8ED^3n}{d^4G} \dots\dots\dots (5)$$

$$S_{S(\max)} = \frac{K_s 8DF}{\pi d^3} \max \dots\dots\dots (6)$$

Where $F_{\max} = 2F$ for continuous loading considered in this design and K_s is known as the shear stress sub factors given as equation (7)

$$K_s = 1 + \frac{0.5}{C} \dots\dots\dots (7)$$

Design of Shaker Sieve

The critical design parameter for the shaker sieve is the diameter of sieve holes. The concept of equilibrium moisture content of the bean was employed in this work. The radius of the bean (r_b) was calculated using equation (8) (Fellow,1993). The volume of grain (V_b) was determined by equation (9) while r_b is the given bulk density of grain.

$$V_b = \frac{4}{3} \pi r_b^3 \quad \dots\dots\dots (8)$$

$$\rho_b = \frac{M_b}{V_b} \quad \dots\dots\dots (9)$$

M_b is the mass of grain, which was obtained by the mole concept for amino acids and glucose in the bean considered for analysis.

Design of Shaker Pulley

In this paper, consideration was given to the chaff pulley diameter, the speed of chaff pulley and the diameter of shaker pulley. All other related aspects of design for the shaker pulley have been considered in earlier works.

Shaker Diameter: - The chaff pulley speed N_c was calculated using equation (10); N_s the speed of shaker pulley is obtained using equation (11) and D_s the diameter of shaker is calculated by equation 12

N_M and D_M are the given speed and diameter of electric motor respectively. Also the diameter of

$$N_M D_M = N_c D_c \quad \dots\dots\dots (10)$$

$$N_s = \frac{1}{3} N_c \quad \dots\dots\dots (11)$$

$$N_c D_c = N_s D_s \quad \dots\dots\dots (12)$$

the chaff D_c was obtained by applying equation 13 (Osborne, 1996; Koya, 1994). In this equation d_2 is diameter of fan impeller from center,

b_2 is axial width of impeller, D_m is diameter of electric motor driving pulley; N_m is speed of electric motor and A_o is cross sectional area of fan outlet. A more detailed and illustrative design has been presented in earlier works (Similowo et al, 2004)

$$V_T = \frac{0.4 \pi d_2 b_2 D_m N_m}{60 A_o D_c} \quad \dots\dots\dots (13)$$

Furthermore, the speed of the shaft was analysed based on the representative free body diagrams of Figure 4 depicting the forced linear vibration experienced by the mass m (sieve) acted upon by a restoring force F (spring) thereby causing a unit displacement x from equilibrium. The second order displacement $\ddot{x}(t)$ the linear velocity

$\dot{x}(t)$ and the speed of shaft N_s are calculated us

$$F = M \ddot{x}(t) \quad \dots\dots\dots (14)$$

$$\dot{x} = \int \ddot{x}(t) dx \quad \dots\dots\dots (15)$$

$$\dot{x}(t) = \frac{2 \pi N_s R_s}{60} \quad \dots\dots\dots (16)$$

Where M is total mass of sieve obtained by density- volume relationship and R_s is radius of shaft pulley.

Determination of shaft Diameter for shaker pulley.

The diameter D for the transmission shaft of the shaker pulley is determined using the ASME code equation given in equation (17). The combined shock and fatigue factors for bending (K_b) and torsion (K_T) are given as 2.0 and 1.5 respectively

$$\left[\frac{16}{\pi S} \sqrt{(K_b M_b)^2 + (K_T M_T)^2} \right]^{\frac{1}{3}} \quad \dots\dots\dots (17)$$

$$M_T = \frac{9550 X K W}{N_s} \quad \dots\dots\dots (18)$$

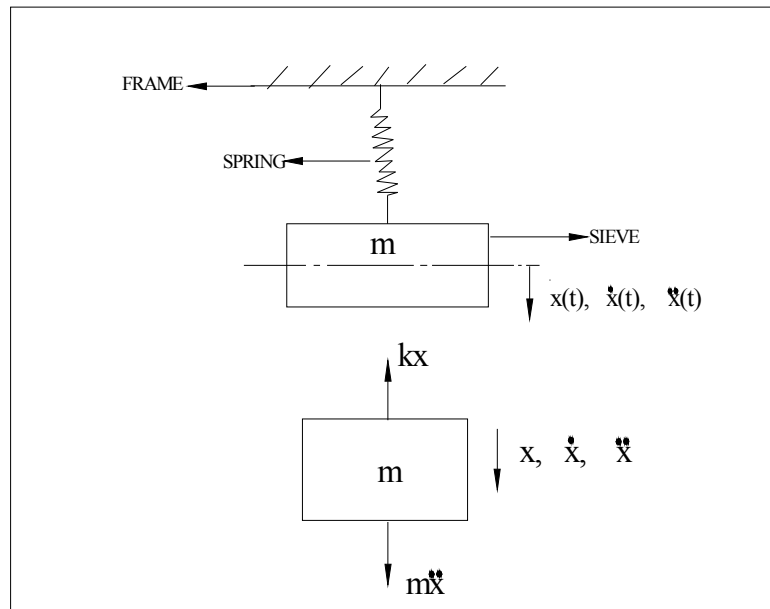

Fig. 4: FREE BODY DIAGRAM

The shaft is designed based on the torsional moment M_T given by equation (18) and maximum bending moment M_b which was obtained by analysis of vertical and horizontal loadings on the shaft

Selection of Bearing Size for Shaker Pulley

The ISO equation for basic rating life for ball bearing given as equation (19); (Allen and Alfred, 2002) was used. L_{10} is the basic rating life in million revolutions; C is the basic dynamic load rating which is recommended to be a life of 20,000-30,000 hours for machine in general, where machines are fully utilized for 8 hours. The exponential life of 3 was applied in design while the equivalent dynamic load P was calculated using equation (20). The radial and safety factors applicable to design are given as 1.0 for both. The thrust load F_a and thrust factor Y are taken to be zero because no thrust loading exists

on the shaker shaft. Radial load F_r is present and was determined by analyses of bearing reactions for vertical and horizontal load

$$L_{10} = \left[\frac{C}{P} \right]^e \dots \dots \dots (19)$$

$$P = XVF_R + YF_A \dots \dots \dots (20)$$

METHODOLOGY OF PERFORMANCE TEST ANALYSIS

The objective of the test was to carry out performance analyses of the sieve (screening test) and blowers (pneumatic tests) of the bean particle-separating machine.

Methodology of performance analysis

Screening test:- The mix i.e. the mixture of beans, chaff and stones were weighed and recorded. The mixes at different feed weights were introduced at a time interval of 120 seconds. The

screened mixes collected at the inclined plate were weighed for each mix introduced. Efficiencies were then obtained for various feed weight of the mix introduced.

Pneumatic test for fan blowers: - The partially cleaned mix collected and weighed earlier was separated manually i.e. by hand picking and the mix were weighed separately and recorded. This was then introduced into line of airflow of the first blower via the inclined plane at various tilt angles (0°, 10°, 20°, 30°). The same process was carried out for the second blower. Efficiencies were obtained for the various tilt angles of the two blowers.

The efficiencies of the screening processes (Eff_s) were determined by equation (21) while those for the pneumatic tests for 1st and 2nd blowers were done with equations (22) and (23) respectively. The overall efficiency of the machine was obtained using equation (24)

$$Eff_s(\%) = \frac{Wm(BF) - Wm(AF)}{Wm(BF)} \times 100 \quad \dots\dots\dots(21)$$

$$Eff_{b1}(\%) = \frac{Wm(AF) - Wc(AF)}{Wm(BF)} \times 100 \quad \dots\dots\dots(22)$$

$$Eff_{b2}(\%) = \frac{Wm(AF) - (Wc(AF) + Ws(AF))}{Wm(BF)} \times 100 \quad \dots\dots\dots(23)$$

$$Eff_{overall}(\%) = \frac{Wmh(BF) - (Wm2(AF))}{Wmh(BF)} \times 100 \quad \dots\dots\dots(24)$$

Where; Wm (Bf) is Weight of mix before separation; Wm (Af) is Weight of mix after separation; Wc(Bf) is Weight of chaff before separation; Wc (Af) is Weight of chaff after separation; Ws (Bf) is Weight of stone before separation; Ws (Af) is Weight of stone after separation; Wmh (BF) is weight of the mix at the hopper before separation (N); Wm2 (AF) is Weight of the mix at 2nd Fan after separation (N)

RESULTS AND DISCUSSION

Efficiency of the Screening Process

Figure 5 shows the efficiencies for the screening mechanism test presented in table (1). At feed

Fig. 5: -Efficiencies of screening processes for different feed weights

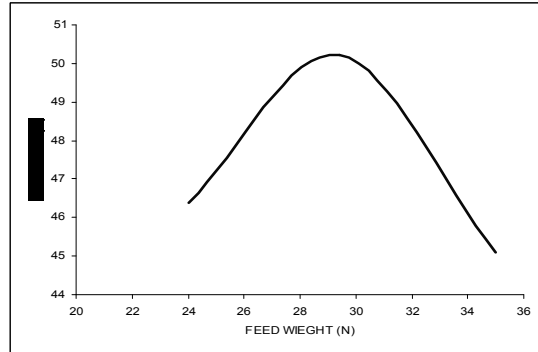

weight of 29.43N i.e. 3.0kg, the sieving process attained its best efficiency of 50.2% for the 2nd trial. The sieve is supposed to partially screen particles bigger in size than the beans.

Efficiency of the First Pneumatic Process

Shown in Figure 6 are the efficiencies for the performance test results for the first pneumatic separator presented in table 2. The weight of the mix considered for a free fall in this analysis is the weight of mix after the screening process with the highest efficiency i.e. 14.72N (1.5kg). Different tilt angles 0°, 10° and 30° were taken for the test.

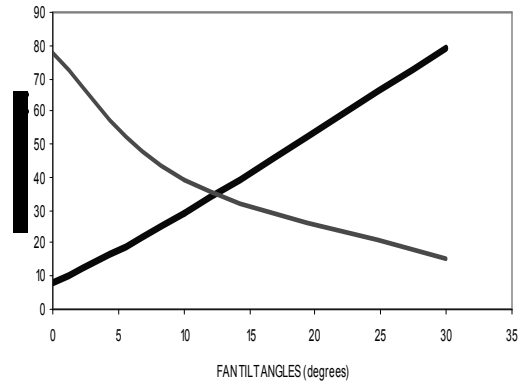

Fig. 6: Efficiencies of Blowers at different tilt angles

The first blower is expected to expel the chaff from the mix in the line of free fall but not to remove the beans. At 0° tilt angle, the intensity of the air velocity was too much to expel not only the chaff but also the beans from the line of free fall. At increase tilt angle of 30°, the intensity of the air velocity was reduced so that only the chaff was blown away and the beans was allowed to continue to fall freely to the line of airflow of the second blower. The tilt angle 30° was consequently adapted for the unit design.

was allowed to fall freely on the line of airflow of the second blower. Different tilt angles 0°, 10° and 30° were also considered for the test. The feed weight considered for this test was the weight of the mix after the chaff had been separated at the best tilt angle with highest efficiency i.e. 11.65N (1.2kg).

The second fan was designed to expel the beans from the mix of free fall only. At 0° tilt angle, the intensity of the air velocity was enough to blow away the beans from the mix. Increase in tilt angle reveals that the intensity of the air velocity was not enough to expel the beans therefore the tilt angle 0° was consequently adapted to design the second blower of the unit.

Table 1: Performance tests results for screening mechanism

Feed Weight (N)	1 st Test	2 nd Test	3 rd Test
Wm (BF)	24.53	29.43	34.34
Wm (AF)	13.20	14.72	18.64

Efficiency of the Second Pneumatic Process

Shown in Figure 6 also are the efficiencies for the performance test results for the second pneumatic separator presented in table 3. The pneumatically separated mix from the first blower

Overall Efficiency of the Machine

The weight considered for the overall efficiency of the machine was that of the experiment with best efficiency at the sieve, and best tilt angles for the chaff and bean blowers. Equation (24) was used in determining this efficiency as 70%. The Efficiency recorded from the performance test analysis showed that the machine could be em-

Table 2: Performance tests results for 1st pneumatic separator

FAN TILT ANGLE	Feed Weight		1 st Test		2 nd Test		3 rd Test		Average	
	Wm	Wc	Wm	Wc	Wb	Wc	Wb	Wc	Wb	Wc
	Bf (N)	(N)	Af (N)	(N)	(Af) (N)	(N)	(Af) (N)	(N)	(Af) (N)	(N)
0°	14.72	2.94	1.18	0	1.18	0	1.18	0	1.18	0
10°	14.72	2.94	4.12	0	4.12	0	4.12	0	4.12	0
30°	14.72	2.94	11.65	0	11.65	0	11.65	0	11.65	0

Table 3: Performance tests results for 2nd pneumatic separator

FAN TILT ANGLE	1 st Test			2 nd Test			3 rd Test			Average		
	Wm	Wc	Ws	Wm	Wc	Ws	Wm	Wc	Ws	Wm	Wc	Ws
	(Af) (N)	(Af) (N)	(Af) (N)	(Af) (N)	(Af) (N)	(Af) (N)	(Af) (N)	(Af) (N)	(Af) (N)	(Af) (N)	(Af) (N)	(Af) (N)
0°	9.05	0	0	9.05	0	0	9.05	0	0	9.05	0	0
10°	4.55	0	0	4.55	0	0	4.55	0	0	4.55	0	0
30°	1.80	0	0	1.80	0	0	1.80	0	0	1.80	0	0

ployed to ensure proper separation of beans from unwanted materials.

CONCLUSION AND RECCOMENDATION

The efficiency of the existing pneumatic separator has been increased due to the incorporation of some other machine components. An efficiency of 50% was obtained for the screening and shaker mechanism of the separator for a feed weight of 29.43N i.e. 3.0kg. Efficiencies of 79.2% at 30° tilt angle and 77.7% at 0° tilt angle were also obtained for the first and second blowers respectively.

In summary, the results of analyses carried out in this work showed that lengthy manual process of beans cleaning and preparation prior to final large-scale consumption has been greatly reduced with the use of this modified separator.

The overall efficiency of 70% for the equipment shows that more improvements could be further made on the pneumatic separator. Also the use of multi-speed electric motors and different detachable sieves are recommended for the machine, thereby making it possible to clean different grains by regulating the speed of the motors.

REFERENCES

- Allen, S.H., Alfred R.H., and Herman, G.L. (1982). *Theory and Problems of Machine Design*. Singapore: McGraw-Hill Publishing Company.
- Koya, O.A. and Adekoya, I.O. (1994). Some Physical and Aerodynamic Properties Relevant in Destoning Some Grain Crops. *Ife Journal of Technology*, 4(2):35-40.
- Lawton, P.J. (1980). Coefficient of friction for seria grains and various wall material agricultural products. 25:75-86. *U.S.A: Pitman Publishing Inc.*
- Osborn, W.C. (1996). *Fans*. London: Pergamon Press.
- Sullivan J.F. (1970). Applications in the seed, grain and milling industries. 13: 1-4. *London Triples Dynamic Suctton Inc.*
- Simolowo, O.E., Dabor, S.E., Aigbokihai, S.O and Awomolo, A. (2004). Performance Analysis of Pneumatic Separators for a Beans Particle Separating Machine. *The Nigerian Academic Forum*. 6(3): 129-133.