

## A review of mechanical cassava peeling and its adoption by processors

Francis Amoah<sup>1,2\*</sup>, Emmanuel Yaovi Hunnuor Bobobee<sup>2</sup>, Ahmad Addo<sup>2</sup>, Joseph Ofei Darko<sup>2</sup> and Joseph Oppong Akowuah<sup>2</sup>

Received: 24 May 2022 / Accepted: 19 August 2022

Published online: 27 October 2022

### Abstract

Cassava has rapidly gained recognition as a very useful crop in Africa and other parts of the world, not just for its consumption domestically, but most importantly for its industrial use. Due to the rapid rate of deterioration, cassava needs to be processed almost immediately after harvest, and peeling is one of the first operations in cassava processing for human consumption. This has led to the development of several mechanical peeling equipment and processes. Therefore, the study reviews mechanical peeling of cassava and efforts at enhancing the adoption of the developed peelers. The review considered some cassava peeling equipment developed by researchers globally within the past decade. From the review, abrasive peeling is the most employed mechanism of peeling. The peelers were operated at peeling speeds in the range of 40 - 3000 rpm and had peeling efficiencies of 12.7 - 100 %, percentage flesh losses of 0 - 44 % and throughput capacities of 6.2 - 1440 kg/h. Generally, an increase in peeling drum speed resulted in a corresponding increase in throughput capacity in all the equipment. Additionally, peeling efficiency and percentage flesh loss in most of the peeling equipment also increased with an increase in peeling drum speed. Unsatisfactory performance and lack of understanding of the operation of the mechanical peeler were identified as possible hindrances to its adoption by processors. Further research is recommended to enhance the adoption and diffusion of mechanical peelers since it has the potential to boost cassava production and enhance industrial cassava processing.

**Keywords:** Abrasive Peeling, Efficiency, Flesh Loss, Speed, Performance

### Introduction

Cassava (*Manihot esculenta* Crantz) is a multipurpose crop grown in many tropical and subtropical regions of the world. Worldwide, Africa is the highest producer of cassava with Nigeria being the lead-producing country and contributing about 20 % to the global production (Bobobee and Yakanu, 2018; Ebewore and Isiorhovoja, 2019; Ilori and Adetan, 2013; Nathan *et al.*, 2017). Ghana's cassava production has been increasing from about 12.23 million tonnes in 2009 to 20.85 million tonnes in 2018, and currently ranks sixth in terms of global production (Bobobee, 2019; FAOSTAT, 2019). The importance of cassava to the economy and food security of Ghana cannot be overemphasised. It contributes about 22 % to the Agricultural Gross Domestic Product (AGDP) and constitutes about 50 % of all roots and tubers cultivated by small-scale farmers in the country (Aidoo *et al.*, 2019). Being a drought-resistant crop, it has the potential of withstanding the current situation of climate change and, hence, can be relied

on to sustain the food security of the country's population, especially among rural dwellers and the less privileged. It is traditionally used in the preparation of several foods like cassava grits (gari), cassava dough (agbelima), cassava pellets (kokonte), boiled cassava (ampesi), pounded boiled cassava (fufu), etc. Commercially, it can be processed into bioethanol, adhesives, chips, and high-quality cassava flour (HQCF) or used by the pharmaceutical, plywood, paper and textiles industries (Ibegbulem and Chikezie, 2018; Sajeev *et al.*, 2010).

Cassava processing usually involves some operations like washing, peeling, grating, chipping, milling, dewatering, sieving and drying (Aji *et al.*, 2016; Oriola and Raji, 2013a). Most of these processing operations have been successfully mechanised, resulting in technologies, which have been adopted at the small and medium scale levels of processing. However, peeling, which is mostly done manually, is estimated to constitute about 65 % of the time spent in processing (Davies *et al.*, 2008). This means adopting mechanised means of peeling will greatly reduce the total duration of processing and level of postharvest losses.

Several peeling equipment have been developed and evaluated by researchers, especially in Nigeria. However, according to Oyelade *et al.* (2019), processors are still heavily dependent on manual peeling for their operations. This could be as a result of existing peelers not meeting the expectation or requirements of processors.

---

\*Corresponding authors's email:  
famoah2020@yahoo.com

<sup>1</sup>Department of Agricultural Engineering, Ho Technical University, Box HP217, Ho, Ghana

<sup>2</sup>Department of Agricultural and Biosystems Engineering, KNUST, Kumasi, Ghana

According to Egbeocha *et al.* (2016) and Tobiloba *et al.* (2019), existing peelers may not be satisfactory because of their moderate peeling efficiencies and high level of flesh losses. This paper, therefore, reviews existing peelers and peeling methods, their working mechanisms and evaluation, as well as the need for the adoption of mechanical peelers by processors among other things. By way of the procedure, scientific papers published globally on the subject were obtained from various search engines and databases like Google Scholar, Google, Scopus and Access Global Online Research in Agriculture (AGORA). The search focused on methods of cassava peeling, classification and mechanisms of mechanical peelers, some recently developed improved peelers, factors that influence the effective performance of the peelers and adoption of agricultural technologies. The papers were assessed and the ones appropriate for the study were selected, reviewed and summarised for use. Other researchers like Egbeocha *et al.* (2016), Osei (2020) and Tobiloba *et al.* (2019) have worked on similar review papers in the past. This paper however includes recently developed peelers and, also, deals with the adoption of these peelers, a subject other review papers did not consider.

### Peeling and Peeling Methods

The cassava root is composed of the outer periderm, which is also called the bark or skin, the cortex and then the starch-rich inner portion, which makes up the bulk of the cassava (Egbeocha *et al.*, 2016; Jimoh *et al.*, 2014a). The periderm and the cortex make up the cassava peel, which needs to be removed in most processing operations of the cassava for human consumption (Alhassan *et al.*, 2018). As a result of a thin cambium layer separating the peel from the flesh, the peel is quite distinct and attaches relatively loosely to the flesh, unlike in other root and tuber crops like yam, potato and cocoyam (Jimoh *et al.*, 2014a).

Peeling is the process of removing a thin layer usually called the peel from a stock (Tobiloba *et al.*, 2019). In cassava, this process makes available the useful starch-rich flesh while eliminating the peel, which has a high concentration of hydrogen cyanide (Evuti *et al.*, 2010; Ibegbulem and Chikezie, 2018). The thickness of the cassava peel has been reported to range between 1.19 – 4.72 mm (Ademosun *et al.*, 2012; Adetan *et al.*, 2003; Ilori *et al.*, 2017; Oriola and Raji, 2013b). This means that effective removal of the peels or peeling by whatever means should be within this range of depth. Removing more than the thickness of the peel will result in cassava flesh loss while removing less than the thickness results in inefficient peeling.

Generally, four common methods of peeling have been widely reported. These methods are manual, chemical, steaming and mechanical methods, with each having its merits and demerits (Abdulkadir, 2012; Egbeocha *et al.*, 2016; Evuti *et al.*, 2010; Jimoh *et al.*, 2014b; Tobiloba *et al.*, 2019). Some peeling equipment and procedures also combine some of the methods with the quest of achieving higher performance (Barati *et al.*, 2020, 2019).

The manual method of peeling was the first method of peeling employed by processors. It is mostly used in traditional processing. It is reported to be the most efficient in terms of peeling efficiency and cassava flesh loss, and it serves as a reference (with respect to flesh-to-peel ratio determination) in the evaluation of many mechanical peelers (Akintunde *et al.*,

2005; Edeh *et al.*, 2020). However, it is said to be low-yielding, time-consuming and involve much drudgery, making it unreliable for commercial processing of cassava roots (Alli and Abolarin, 2019; Oluwole and Adio, 2013). Again, it has been described to be expensive due to the high involvement of labour employed (Kolawole *et al.*, 2010). Manual peeling began with the use of stones and wooden tools, and currently employs simple household knives (Oluwole and Adio, 2013). Improved manual peeling tools (Figure 1) have also been developed by the National Centre for Agricultural Mechanization (NCAM) and the International Institute of Tropical Agriculture (IITA) to enhance the peeling process. These tools, having a capacity range of 30-40 kg/h and flesh loss of less than 1%, were designed for easy handling and safety of the users. Manual peeling usually involves two methods, depending on the level of adherence of the peel to the flesh (Tobiloba *et al.*, 2019). For easy-to-peel varieties, the peel is slit along the root length at one side and then separated from the flesh by unwrapping it with the aid of a knife or the fingers (unwrapping method). On the other hand, in varieties that the peel adheres relatively tight to the flesh, peeling is done by cutting off the peel with the knife or peeling tool in a motion comparable to sharpening a pencil with a cutter (shearing method). This method is however not as efficient as the unwrapping method because it results in some level of flesh loss as well as leaving some peel on the flesh (Ilori and Adetan, 2013; Tobiloba *et al.*, 2019). Despite this limitation, most processors prefer this method because it is faster compared to the unwrapping method.



**Figure 1** (a) NCAM and (b) IITA cassava peeling tools (Kamal and Oyelade, 2010)

Chemical peeling involves the use of chemicals in softening and removing the peels of food crops. The most commonly used chemical is a hot solution of sodium hydroxide (lye), which has been successfully applied in the industrial peeling of potatoes (Adetan *et al.*, 2006). However, the application of this method to cassava has been objected due to the physiological differences between potatoes and cassava. Since cassava has tougher peels than potatoes, it will require higher concentration, longer immersion time and higher operating temperature and pressure, which will eventually affect the quality of the processed cassava (Oluwole and Adio, 2013; Tobiloba *et al.*, 2019).

The steaming method of peeling involves subjecting the products (usually fruits and vegetables) in a pressure vessel to pressurised steam for a very short period (Abdulkadir, 2012). The duration is short (one or two minutes) to avoid partial or eventual cooking of the products. Due to the tough and irregular nature of cassava peels compared to a vegetable like tomatoes, a longer period of steaming will be required, which will affect the colour of the final product in an undesirable

manner (Tobiloba *et al.*, 2019). This makes it not preferable for peeling cassava roots.

Mechanical peeling method involves the use of mechanical equipment to remove the peels. It involves interactions between a peeling mechanism and the material being peeled. There are different types of peeling mechanisms employed in the peeling of cassava (Abdulkadir, 2012). Mechanical peeling is the most ideal method of peeling in terms of commercial processing of cassava because it is cost-effective, environmentally friendly, nontoxic, less tedious and fast (Egbeocha *et al.*, 2016; Shirmohammadi *et al.*, 2012). The major limitations however have been the high loss of cassava flesh and low level of peeling efficiency experienced by some peelers (Jimoh *et al.*, 2014b). Different peeling equipment have been developed by various researchers across the globe. The following sections evaluate some of the major types of mechanical peeling methods and equipment.

### Classification of mechanical peelers

A completely mechanised cassava peeling equipment would ideally include units for reducing the roots to appropriate sizes, feeding the reduced sizes into the peeling unit, peeling the cassava, discharging the peeled roots (flesh) and waste, and washing the flesh for further processing (Ohwovoriole *et al.*, 1988). However, since operations like size reduction and washing of the roots have been successfully mechanised, most mechanical peeler designs focus on the operation of peeling and some other necessary supporting units. Hence, most cassava peelers have units such as a frame, feeding unit, peeling unit, discharge or delivery unit and powering unit.

The frame serves as a support for all the other units of the equipment, hence must be strong enough to withstand all the vibration and loads imposed on it. The feeding unit is the unit through which cassava is loaded into the equipment to be peeled. Due to the physical properties (size, weight and shape) of cassava, the feeding unit must be designed appropriately to ensure proper operation. It must be spacious enough to accommodate the roots and release them to the peeling unit. As a result, some equipment employ a simple gate for feeding, especially batch-type peelers (Oluwole and Adio, 2013). Another type of feeding unit utilised mostly is a hopper (usually wide, long and/or inclined) (Alli and Abolarin, 2019; Ebomwomyi *et al.*, 2017; Pius and Nwigbo, 2017). The design of the hopper should allow for a free gravitational flow of the cassava roots into the peeling unit. The peeling unit is responsible for removing the peel from the flesh and can be generally categorised into abrasive, knife, lathe or a combination of any of these. The delivery unit releases the peeled cassava and peels after the peeling operation. The powering unit is mostly made up of either an electric motor or a diesel engine with the associated power transmission components (belts, gears or chain and sprocket). Human power in the form of cranking or pedalling is also employed by some equipment. In addition to these basic units, some equipment have additional units such as slicing, washing or pre-treatment units as well.

The peeling unit is the most important unit of the peeler because it is that which determines its performance. Most cassava peelers are designed with the peeling unit oriented horizontally, inclined or vertically (Amanor and Bobobee, 2020; Okoronkwo *et al.*, 2019). For this study, peelers have

been classified based on the type of peeling mechanism employed or the mode of the feeding/discharge of the peeling unit.

### Types of peeling mechanism

A peeling mechanism is the section of the peeling unit with the sole task of separating the peels from the flesh. For effective operation, it is designed based on the physical and mechanical properties of the cassava root, peels and flesh. As indicated, the main types of peeling mechanisms employed in cassava peelers are abrasive, knife and lathe mechanisms. Some peeler designs also combine abrasive and knife mechanisms intending to improve peeler performance (Pius and Nwigbo, 2017).

#### Abrasive mechanism

Abrasive peeling involves the use of abrasive surfaces or units such as wire brushes, wire gauze, perforated metal sheets, rough concrete or hard wood surface (Amanor and Bobobee, 2020; Chilakpu, 2017). These units remove the peels by following the principle of abrasive wear, which involves cutting, ploughing and/or rubbing (Hou and Komanduri, 2003). Depending on the type of unit employed, peeling may mostly be due to any of these principles or a combination of them. For example, Alli and Abolarin (2019) refer to the brush type of peeling unit as a quasi-knife. They indicate that even though the brush type produces an abrasive effect, the individual brushes act like knives on the cassava and hence need to be treated as such. Acting as knives mean they operate chiefly by cutting the peels, even though some level of ploughing might be experienced. On the other hand, a concrete or hard wood surface will remove peels basically by rubbing.

Majority of the existing peelers employ the abrasive mechanism (Alli and Abolarin, 2019). This could be because there are diverse abrasive surfaces or units that can be employed in the design of peelers as well as the ease of operation and manufacture of these abrasive mechanisms (Adetan *et al.*, 2005). They are usually designed either in the form of a drum or a series of peeling shafts or tools forming a concave unit. The abrasive surface or unit is fixed to the rotating member (shaft, drum or disc) or can be on both the rotating unit and the fixed drum (peeling chamber or housing) (Amanor and Bobobee, 2020; Oluwole and Adio, 2013).

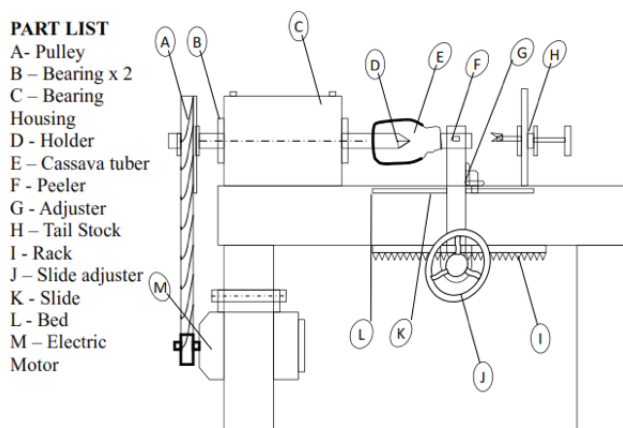
In the design of abrasive peelers, a number of peeling shafts or rollers are sometimes employed to increase the area of contact between the abrasive surface and the cassava roots for efficient peeling. For example, an abrasive peeler with four peeling shafts (Type 4 peeler) performed better in terms of peeling efficiency and throughput capacity but not flesh loss, when compared with one having two peeling shafts (Type 3 peeler) (Nathan *et al.*, 2017). In such multi-roller designs, the relative direction of rotation of the rollers may influence the efficiency of peeling. Peeling rollers that rotate in the same direction produce higher peeling efficiencies compared to those that rotate in the opposite directions (Sagragao and Tan, 2008). This is because the rotation of rollers in the same direction results in an effective turning of the cassava roots leading to an even peeling around the cassava. Peeling efficiencies in the range of 12.7 - 99.5 % have been reported by various researchers, with the flesh loss range being 1.9 - 42.7 % for abrasive peelers (Amanor and Bobobee, 2020; Chilakpu, 2017; Daniyan *et al.*, 2016).

### Knife mechanism

The use of the knife peeling mechanism was first implemented in the earlier designs of cassava peelers by researchers (Odigboh, 1976; Ohwovoriole *et al.*, 1988). This may be due to the reason that since manual peeling involves the use of a knife, designers intended to simulate that operation in mechanical peelers. The knife mechanism involves the use of knives or cutting blades to effect the peeling operation. The mechanism is mostly developed as a cylinder with knives installed around its circumference or in the form of a bed/platform of knives. Knife mechanism operates basically by cutting and some by shearing, depending on the design (Ogunlowo *et al.*, 2016; Sumaria and Tan, 2018). Research indicates the performance of knife mechanism peelers to be 15.2-94.6 % for peeling efficiency and 1.57 - 44 % for flesh loss.

### Lathe mechanism

This is the type of mechanism whereby the work piece (cassava) is held by the machine and rotates about its axis while the tool moves along it, removing the material (peel) as it moves. The application of this mechanism in cassava peeling was utilised as a novelty by Ebunilo *et al.* (2013), even though it was first recommended for consideration by Abdulkadir (2012). Ebunilo *et al.* (2013) designed, fabricated and tested a mechanical cassava peeler, which operates on the lathe mechanism at a speed of 3 rev/s (Figure 2). It had a self-loading and self-adjusting single-point peeling tool designed to follow the contour of the cassava in order to reduce the level of flesh loss. The equipment was able to achieve peeling efficiency of 70 - 92 % for different categories of cassava (from freshly harvested to 4 days after harvest). The operation of the peeler was not affected by the number of days after harvest of the cassava. The study indicated that flesh loss was minimal. Some of the limitations identified with the design were difficulty in identifying the correct centre of the cassava, insufficiently rigid cutting tool holder during peeling and unsatisfactory sensitivity of the peeler to surface irregularities on the cut cassava root sections.



**Figure 2** Cassava peeler using the lathe peeling mechanism (Ebunilo *et al.*, 2013)

### Feeding or discharge mode

How cassava is fed into the peeling equipment before peeling or discharged after peeling can be used to classify the equipment. There are basically two options for this method of classification, namely batch and continuous processes.

### Batch process

The batch peeling process involves the peeling of a certain quantity of cassava at a time. The equipment is designed such that, once the peeling operation begins, no more cassava can be added until the peeling chamber is emptied after peeling. Due to the nature of their operations, a number of them employ a simple gate or lid as a means for feeding and discharge, instead of hoppers and chutes. This makes such designs simple and less expensive, with the main unit being the peeling unit. Most of the batch peeling equipment are fed while the equipment is stationary, before peeling begins (start on load). According to Chilakpu (2017), starting the equipment on load greatly impedes its smooth starting and results in a longer duration of the peeling operation. Discharging also requires that the equipment stops operation, resulting in further loss of man hours. Another negative aspect of batch peeling equipment (especially vertically oriented abrasive peelers) is the grating of cassava roots when the peeling unit is filled with too much cassava. In such situations, the weight exerted by the upper lying roots on those below causes them to experience excessive grating (Alhassan *et al.*, 2018; Okoronkwo *et al.*, 2019). This means effective loading (drum fill) for every batch peeler needs to be determined for efficient performance.

### Continuous process

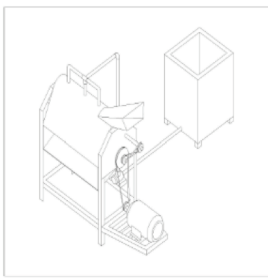
Continuous process peelers are the types that employ continuous feeding and discharge of the cassava roots while in operation. There is no need for the peeler to stop operation for either feeding or discharge of the cassava being processed, allowing for uninterrupted peeling of all the cassava expected to be processed at a given time. This removes the time lost due to intermittent stopping for feeding and discharging of cassava, as experienced in batch process peelers. To ensure a continuous flow of materials, most peelers of this type utilise augurs or other material handling units for the movement of the cassava from the point of feeding to the point of discharge (Alli and Abolarin, 2019). This makes continuous process peelers more complex and have more units than batch peelers. Some are also designed to allow for the gravitational flow of the cassava during peeling (Pius and Nwigbo, 2017). Again, others have the peeling units designed such that they aid in moving the cassava from the point of feeding to delivery (Jimoh *et al.*, 2016; Ugwu and Ozioko, 2015).

### Some Improved Forms of Mechanical Peelers

This section looks at some recently developed peelers by various researchers. The report is limited to recent (within the last 10 years) developments because most of these recently developed peelers resulted from modifications and improvements of designs produced earlier on. From available literature, the first cassava peeler was reported by Odigboh (1976). It was an equipment with a cylindrical knife assembly and a solid cylinder installed parallel to each other on an inclined frame and separated by 20 mm space. Its performance resulted in a peeling efficiency of 75 - 95 % and a capacity of 165 - 185 kg/h. After this, several other equipment have been developed, some of which have been discussed here.

Olukunle and Akinnuli (2012) developed a continuous single-action cassava peeling machine (Figure 3). The peeling

unit is a 200 mm diameter roller with inclined knives installed 70 mm from each other around the roller. The roller is also equipped with an auger for the movement of the tubers and a water supply system for cleaning the peeled cassava. After evaluating the peeler with a variety of IITA's new high-yielding cassava (TMS 30572) at 100-600 rpm peeler roller speeds, peeling efficiency of 60 - 75%, flesh loss of 12 - 44% and capacity of 76 - 442 kg/h were obtained for different categories of tuber sizes. It was observed that the level of breaking of the cassava at higher speeds was high, coupled with other poorer performances; hence the machine was recommended for operation at low speeds. Jimoh and Olukunle (2012) also evaluated and reported similar results for an automated cassava peeler.



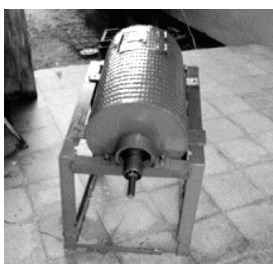
**Figure 3** Single cassava peeler (Olukunle and Akinnuli, 2012)



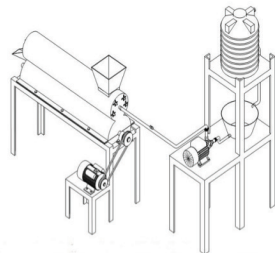
**Figure 4** Automated cassava peeling system (Olukunle and Akinnuli, 2013)

Olukunle and Akinnuli (2013) developed an automated cassava peeling system and an equation for predicting the performance of the peeler as well. The peeler has cutting, metering and peeling units which aid in automatic feeding of the machine with cassava cut to size and oriented appropriately (Figure 4). The peeling unit consists of an abrasive brush and a conveyor (attached with a brush). It was developed based on the principle of a continuous tuber feeding system and peel removal achieved through the action of the shear force created by the opposing motion of the peeling tool. Evaluation of the peeler at peeling brush and conveyor speeds of 500 - 3000 rpm and 150 - 275 rpm respectively resulted in peeling efficiencies of 83.80 - 88.50 % while the developed equation predicted peeling efficiency with a certainty of 88.73 %.

A batch cassava peeling machine was developed and evaluated by Oluwole and Adio (2013). It was designed based on the principle of abrasive peeling, using a stationary outer abrasive drum (of 30 cm diameter and 550 cm length) and a rotating inner abrasive drum (of 12 cm diameter and 520 cm length) which was evaluated at speeds of 364 rpm and 394 rpm (Figure 5). It was designed to peel six cut pieces of cassava per



**Figure 5** Batch cassava peeler (Oluwole and Adio, 2013)

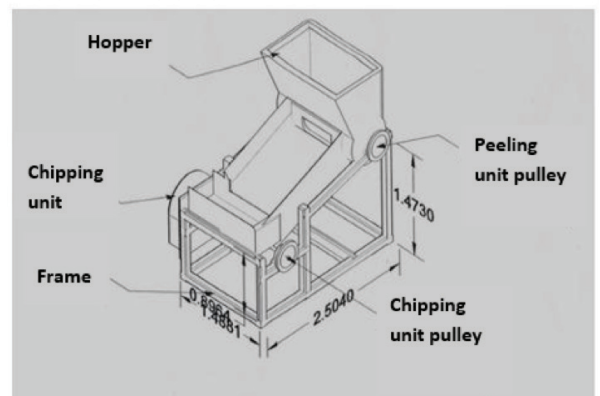


**Figure 6** Cassava peeling and washing machine (Ugwu and Ozioko, 2015)

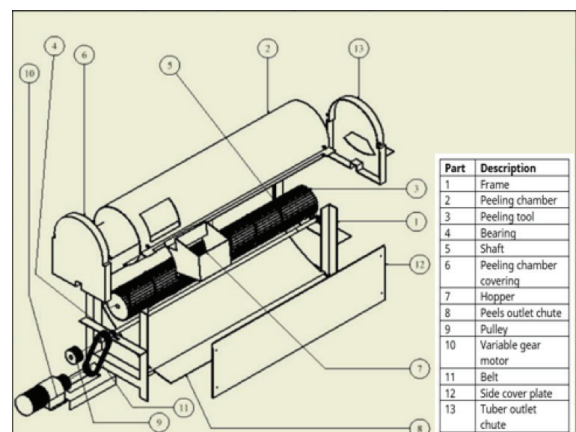
batch. Evaluation of the peeler resulted in peeling efficiency of 60.22 - 70.34 %, flesh loss of 5.09 - 5.95 % and capacity of 30.24 - 43.2 kg/h. Due to the fixed nature of the clearance (9 cm) between the rotating and fixed abrasive drums, this peeler has the limitation of not being able to peel all sizes of cassava roots.

Ugwu and Ozioko (2015) developed and tested a continuous cassava peeling and washing machine (Figure 6). This peeling system has a unit attached that stores and supplies pressurised water for washing the cassava during peeling. Washing takes place in the upper chamber of the peeler with the help of brushes in the form of shafts. The peeling drum, which is housed in the lower portion has an auger incorporated for material transport. Evaluation of the peeler at 380, 420 and 460 rpm speeds resulted in 70 % as the best peeling efficiency at 420 rpm. Performances at the 380 and 460 rpm speeds were lower, hence were not recommended for operation.

Aji *et al.* (2016) developed a continuous electrically operated cassava peeling and slicing machine (Figure 7). The slicing unit is positioned at the lower end of the frame while the peeling unit is welded on the upper part such that it makes an angle of inclination of 40° with the slicing unit surface. The peeling drum is abrasive, specifically of the type constructed from a perforated metal sheet. A machine speed of 1150 rpm was used in its operation. The machine had a capacity of 403.2 kg/h, peeling efficiency of 66.2 %, slicing efficiency of 84 %, flesh loss of 8.52 % and overall efficiency of 82.4 %. It was evaluated to have an overall cost of \$150 and can be operated and maintained by an individual.



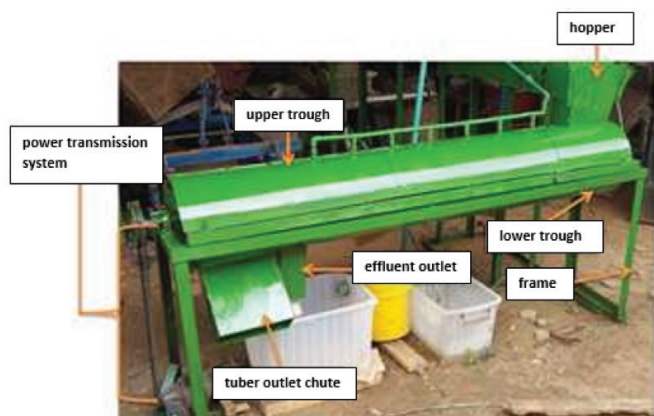
**Figure 7** Cassava peeling and slicing machine (Aji *et al.*, 2016)



**Figure 8** Continuous cassava peeler (Jimoh *et al.*, 2016)

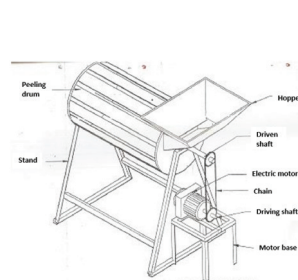
Jimoh *et al.* (2016) used dimensional analysis to develop the relationship between machine functional properties and some identified crop and machine variables during mechanical peeling. Figure 8 shows the peeler used in this study. To attain peeling in all directions, the peeling chamber was designed with a curvature which enables displaced roots to return to the peeling tool. The peeler was designed to have a smooth-edged peeling tool which was evaluated at 100, 110, 120, 130 and 140 rpm speeds and a serrated-edged peeling tool evaluated at 140, 145, 150, 155 and 160 rpm speeds. The evaluation was also at different feed rates of 10, 20, 30, 40 and 50 kg of the improved cassava variety TMS 30572 for both peeling tools. Machine functional parameters recorded optimum performance for the smooth-edged peeling tool at 130 rpm speed and 10-20 kg feed rate while that for the serrated-edged peeling tool occurred at 160 rpm speed and 30 kg feed rate. The study established a linear relationship between machine speed versus a ratio of the velocity of conveyance and peeling time.

An automatic cleaning, peeling and washing machine was developed and evaluated by Ogunlowo *et al.* (2016) for cassava processing (Figure 9). The peeling unit is composed of a rotary drum inscribed with cutting blades of height 10 mm and length 2700 mm and an auger of thickness 2 mm length and 2700 mm. The machine was evaluated at five peeling drum speeds (40, 45, 50, 55 and 60 rpm), five tuber loadings (1, 2, 3, 4 and 5 tubers) and three options for days after harvest (1st, 2nd and 3rd days). Peeling efficiencies for first, second and overall peeling throughput were 69–83 %, 55–75 % and 86–95 %, respectively.

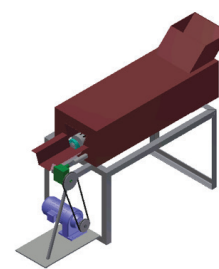


**Figure 9** Automatic cassava cleaning, peeling and washing machine (Ogunlowo *et al.*, 2016)

Chilakpu (2017) modified and improved the performance of the rotating drum cassava peeling machine by Chilakpu and Asoegwu (2010). Some of the modifications incorporated were the addition of more rough edges by the introduction of rough seasoned iroko woods, increasing the size of the drum, reducing the speed of the drum and introducing a hopper with shuttering mechanism by the side of the drum (Figure 10). By this modification, the machine was able to start under no-load condition while a measured quantity of cassava root is introduced through the hopper. The modified machine had a peeling efficiency of 97 %, flesh loss of 8 % and capacity of 700-1000 kg/h at an average speed of 1500 rpm. The modified peeler performed better than the earlier design, which recorded at the same speed (1500 rpm) peeling efficiency, flesh loss and capacity of 89.7 %, 8.6 % and 300-500 kg/h, respectively.



**Figure 10** Self-loading cassava peeler (Chilakpu, 2017)



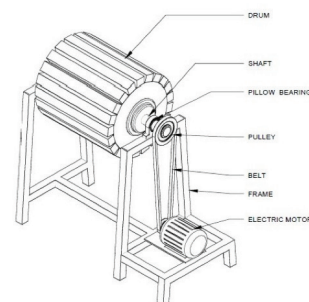
**Figure 11** Inclined cassava peeling machine (Pius and Nwigo, 2017)

Pius and Nwigo (2017) developed a continuous cassava peeler, which employs both a knife (peeling) cylinder and an abrasive cylinder running in counterrotation as the peeling unit (Figure 11). Clearance between the two cylinders was designed such that it enabled creating the needed force for peeling the smallest cassava root. This was achieved by employing an idle shaft below the two cylinders, which supports small roots and aids in the rolling action of the roots. The design incorporates a spring-loaded mechanism, which aids in exerting the required pressure for peeling. This continuous peeler does not use any auger or material handling unit but relies on the inclined nature of the frame to transport the cassava by gravity from point of feeding to discharge. The machine had an average peeling efficiency of 70.6 % at a speed of 72 rpm.

Adekunle *et al.* (2018) developed a cassava peeling machine, which utilises a large peeling drum (sun) on top and a few smaller drums and augers (planetary) below as the peeling mechanism (Figure 12). The planetary cutting mechanism is arranged in a semi-circular shape and is intended to rotate and peel the tubers (both small and large roots) from the bottom. On the other hand, the main cylindrical cutter (sun) handles mainly large roots. Evaluation of the peeling machine using average cassava diameters of 33.15, 42.09 and 52.15 mm resulted in peeling efficiencies of 76.92, 82.35 and 83.34 %, flesh loss of 8.89, 9.82 and 11.57 % and throughput capacities of 103.86, 106.45 and 108.57 kg/h, respectively at a speed of 400 rpm.



**Figure 12** Peeler using sun and planetary mechanism (Adekunle *et al.*, 2018)



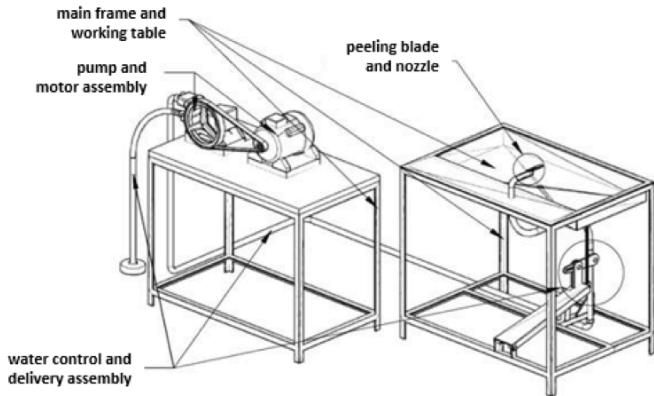
**Figure 13** Peeler using an abrasive mechanism (Alhassan *et al.*, 2018)

Alhassan *et al.* (2018) developed a batch cassava peeler, which uses an abrasive mechanism in the form of wire brushes fitted within grooved parts of a wooden drum (Figure 13). Initial operation of this peeler at a high speed resulted in the cassava cleaving to the drum, leading to no peeling taking place. However, the machine performed well at a reduced speed.

of 58 rpm with the aid of a reduction gear, resulting in the highest peeling efficiency of 74 %, machine capacity of 31 kg/h and minimum flesh loss of 5% at 10 – 50 % drum fill for 20 – 30 minutes peeling time. This design is similar to that modified by Chilakpu (2017), even though the latter performed better in terms of peeling efficiency while the former had better flesh loss.

A waterjet-assisted cassava peeler as shown in Figure 14 was developed and evaluated by Sumaria and Tan (2018). The peeling mechanism of this peeler consists of a blade welded parallel to the top side of a nozzle, which is connected to the water delivery system. The nozzle was designed to have two options, namely flat and circular openings. To achieve peeling, the blade cuts through the cassava peel, after which the water jet applies pressure between the cassava flesh and the peel leading to their separation.

Feeding of the peeler happens one cassava root at a time. Since actual peeling is done with the aid of pressurised water, this peeler cannot, in reality, be classified as a knife peeler, and neither is it an abrasive type. Evaluation of the peeler using the Lakan cassava variety resulted in peeling efficiency of 100 %, flesh loss of 0 % and capacity of 21.68 – 25.68 kg/h. Even though this peeler had low capacity, it produced excellent results in terms of peeling efficiency and flesh loss. It also requires relatively large volumes of water for its operation, which may be a limitation when peeling cassava in commercial quantities. Again, evaluating the peeler using different cassava varieties, especially varieties with the peel closely adhering to the flesh will give a better appreciation of its performance.

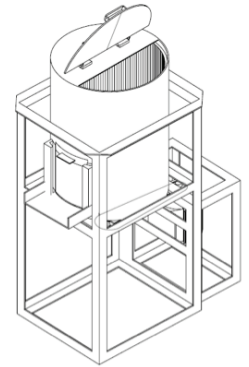


**Figure 14** Waterjet-assisted cassava peeler (Sumaria and Tan, 2018)

Alli and Abolarin (2019) modified the design of Ohwovoriole et al. (1988) to improve its performance (Figure 15). The modified design had two peeling shafts rotating in opposite directions and an auger as the peeling unit. The peeling shafts have brushes fixed uniformly around them, which undertake the peeling operation. The brushes operate like deflectable knife edges such that they can adjust to accommodate different cassava shapes and sizes. Evaluation of the machine was undertaken at 50-250 rpm conveyor/brush speed and 45 – 70 % cassava root moisture content. Maximum peeling efficiency of 80.9 % at a maximum moisture content of 70 % and minimum speed of 50 rpm was recorded. It had a throughput capacity of 47.9 kg/h



**Figure 15** Cassava attrition peeling machine (Alli and Abolarin, 2019)



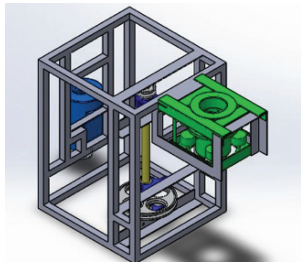
**Figure 16** Portable cassava peeling machine (Okoronkwo et al., 2019)

Okoronkwo et al. (2019) developed a portable vertically oriented batch cassava peeling machine (Figure 16). The peeler has a stainless-steel drum with a lining made from zinc abrasive material and a peeler disc which is powered by an electric motor. Rotation of the peeler disc produces a centrifugal force, which causes the cassava to be moved outwards towards the abrasive drum lining leading to peeling as they rub against the lining. Overloading the drum with cassava will lead to grating of the roots in direct contact with the peeler disc. Peeling efficiency was 91.72 % while capacity was 582 kg/h at a speed of 784 rpm.

Olayanju et al. (2019) also worked on a vertically oriented ceramic cassava peeling and washing machine (Figure 17). It is composed of a peeling drum which houses the abrasive portion responsible for peeling and a turn table. The abrasive medium was constructed from ceramic (crushed toilet sink) material, sand and cement in the ratio of 1:3:1, respectively. The turn table is powered by a 10 hp low-speed motor and gives motion to the cassava in the drum, causing them to be peeled as they rub against the abrasive medium. Performance of the peeler resulted in peeling efficiency of 63.64 – 68.97 %, flesh loss of 22.38 - 37.5 % and capacity of 104.4 - 223.2 kg/h with weights from 3.5 to 15.5 kg at a speed of 144 rpm. The best performance was recorded at 15.5 kg while the 3.5 kg produced the lowest performance of the machine.



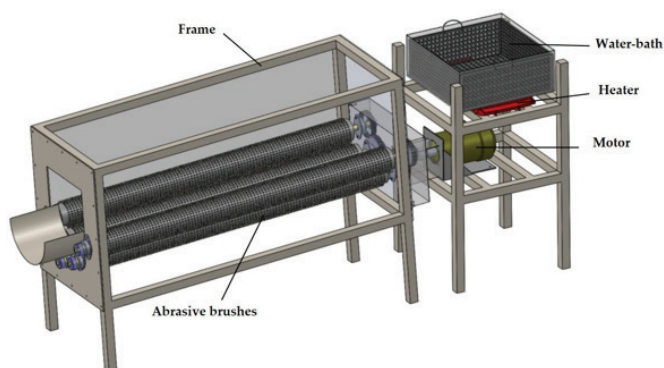
**Figure 17** Ceramic peeling and washing machine (Olayanju et al., 2019)



**Figure 18** Cassava tuber knife peeling unit (Pariyed *et al.*, 2019)

Figure 18 shows the knife peeling unit developed by Pariyed *et al.* (2019). This peeler consists of the frame, knife peeling set, transmission unit and power source. The knife peeling set had a tapered shape, with a diameter of 75 mm at the upper knife set and 60 mm at the lower knife tube set. The blade of the knife set is inclined at  $30^\circ$  by the tangent to the cassava during peeling. The working principle of the peeler is that peeling must take place as a cassava root is fed from the upper to the lower knife set and the knife rotates around it. It was evaluated using the sweet-type cassava variety (locally termed 5 minutes) at 70, 80 and 90 rpm knife speeds, with three knife types and two levels (8.21 and 17.19 N/m) of knife spring stiffness. The recommended operating conditions based on evaluation were 90 rpm, second peeling knife type and 17.19 N/m stiffness. The peeler had a peeling efficiency of 90.3 % and a flesh loss of 3.63 %. One limitation of this peeler is the fact that it cannot peel very big and small cassava roots due to the knife peeling set being designed to have a fixed dimension.

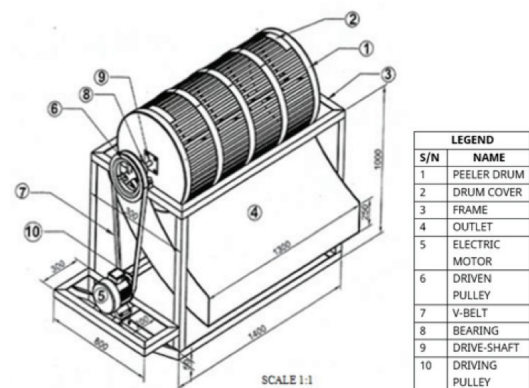
Barati *et al.* (2019) evaluated the performance of an abrasive peeler using cassava roots pre-treated by a freeze-thaw method. The cassava roots were frozen at  $-18^\circ\text{C}$  for 24 h and treated at five different temperatures (50, 60, 70, 80, and  $90^\circ\text{C}$ ) and five incubation times (0, 30, 60, 90, and 120 s) in a water bath. Figure 19 shows the peeler used in this experiment, with the following components: frame, peeling unit, water bath with heating system, motor and frequency converter. It has overall dimensions of  $1500 \times 500 \times 1000$  mm and employs five rotating abrasive brush rollers as the peeling mechanism. The peeler was evaluated at five rotational speeds (550, 700, 850, 1000, and 1150 rpm) and five peeling times (1, 2, 3, 4, and 5 min). The most efficient process conditions of 1000 rpm speed, 3.4 min peeling time,  $59^\circ\text{C}$  thawing temperature and 90 s incubation time produced peeling efficiency of 99.5 % and flesh loss of 19 % after freeze-thawing.



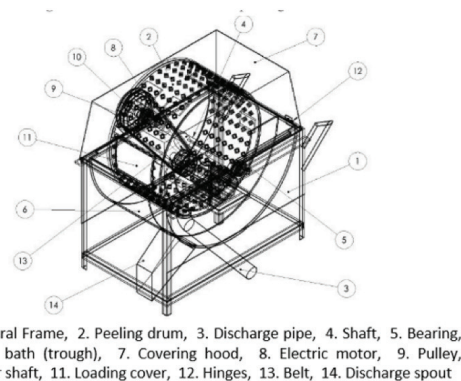
**Figure 19** Abrasive peeling machine with pre-treatment unit (Barati *et al.*, 2019)

In another research involving a combination of mechanical and chemical methods of peeling, Oyedele *et al.* (2019) assessed the impact of temperature, time of process reaction and concentration of sodium hydroxide (lye) solution on the performance of a wet mechanical brushing peeling machine. The cassava roots (high-yielding yellow variety UMUCASS 44) were treated with 15 % and 20 % lye concentration at  $60^\circ\text{C}$  for 15 and 20 minutes, and 30% lye concentration at  $100^\circ\text{C}$  for 10, 15 and 20 minutes. Each treatment was then subjected to abrasive peeling using the mechanical peeler. Even though the chemical treatment was to enhance digestion of the peel and subsequent removal, the average peeling efficiency of this method ranged between 51.67 – 77.75 %, which is lower than that of many mechanical peelers even without any form of pre-treatment. The best performance (77.75 % peeling efficiency) of the peeler was recorded at 20 % lye concentration at  $60^\circ\text{C}$  for 15 minutes.

Onyenobi and Ikenga (2019) designed a modernised cassava peeling machine based on engineering design principles. The design is of a batch abrasive type, similar in form to that by Alhassan *et al.* (2018), except that the current design is equipped with a delivery spout for discharge (Figure 20). The design efficiency of the machine was 80 %. To ascertain the assertion that the performance of this design will not be affected by the varying shapes of cassava roots, it is recommended that the design be constructed and evaluated.



**Figure 20** Modernised cassava peeling machine (Onyenobi and Ikenga, 2019)



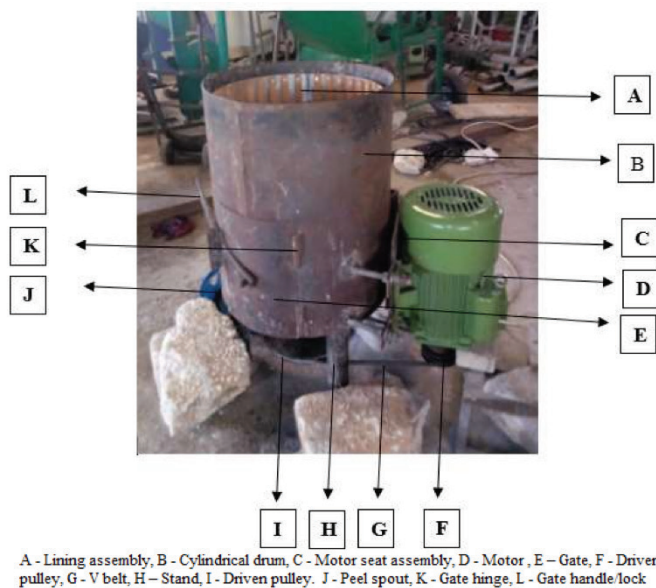
**Figure 21** Modified cassava attrition peeler (Edeh *et al.*, 2020)

Figure 21 shows the modified attrition peeling machine by Edeh *et al.* (2020). Modification of the Projects Development Institute's (PRODA) cassava attrition peeling machine (Ezekwe, 1979) resulted in this. The machine has a frame, power transmission unit, peeling unit, delivery unit, water bath with discharge pipe and covering hood. The peeling unit is



composed of a perforated outer metal casing and 250 egg-shaped peeling balls. The major modifications undertaken were replacing spherical balls with egg-shaped ones, introduction of three baffles within the walls of the peeling drum and improving the abrasive peeling surface of the drum by using a perforated metal sheet instead of an inner drum lining. These modifications resulted in an improvement in the performance of the peeler in terms of the peeling efficiency, percentage flesh loss and throughput capacity when evaluated with three varieties of cassava (UMUCASS 36, TMS 30572 and TME 419). The modified peeler recorded average peeling efficiency, flesh loss and throughput capacity of 75.4 %, 5.88 % and 119 kg/h, respectively, while the original machine had 62 %, 16.66 % and 69.71 kg/h, respectively.

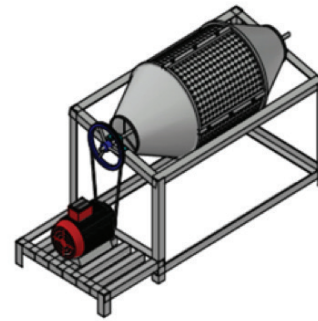
Amanor and Bobobee (2020) also developed and evaluated a cassava peeler that has four different abrasive lining materials namely, concrete, metal, rubber and wood. It consists mainly of a cylindrical drum with the lining assembly, a rotating disc powered by an electric motor and a stand (Figure 22). Abrasive lining material was attached to both the drum and the disc. Allowance was also made for the evacuation of cassava peels, water and the peeled tubers. Evaluation of the peeler at three different speeds (250, 350 and 500 rpm) with two varieties of cassava (Asi-Abayiwa and Dabon) resulted in peeling efficiency of 17.71 – 83.85 %, flesh loss of 1.9 – 38.08 % and capacity of 80 – 1440 kg/h. The study indicates that rubber and concrete discs at 350 rpm produced optimum results in terms of peeling efficiency and flesh loss. This work is similar to the designs by Okoronkwo *et al.* (2019) and Olayanju *et al.* (2019).



**Figure 22** Motorised vertical cassava peeler (Amanor and Bobobee, 2020)

Fadeyibi and Ajao (2020) developed a multi-crop peeler which was tested with cassava, yam, cocoyam and sweet potato. It is composed of a frame, motor and rotating peeling drum, which is lined with a sharp-edged galvanised wire gauze as the abrasive surface (Figure 23). The peeler was evaluated at speeds of 350, 530 and 750 rpm. Effective peeling was achieved for sweet potato and cocoyam compared to cassava and yam. The highest peeling efficiency of 74.6 % was recorded for cocoyam at 750 rpm while the lowest was 40.2 % for yam at 350 rpm. Peeling efficiency for cassava ranged

between 41.4 – 63.8 % from 350 – 750 rpm, with its (cassava) flesh loss being the highest among all crops at all speeds.



**Figure 23** Multi-tuber peeling machine (Fadeyibi and Ajao, 2020)

Table 1 presents a summary of the parameters for the mechanical cassava peeling equipment discussed. Abrasive peeling constitutes a major proportion of the mechanisms employed by the peelers while the batch method of feeding or discharge also constitutes the highest in that category. The simplicity of the design, ease of manufacture and operation, and cost of the equipment could be the reasons for this identified trend (Adetan *et al.*, 2005). The lowest speed of operation reported is 40 rpm with 3000 rpm being the highest speed. Highest peeling efficiency of 100 % is reported by the waterjet-assisted peeler while efficiency of 12.7% produced by an abrasive batch peeler represents the lowest. Again, the waterjet-assisted peeler reported the best performance of no flesh loss (0 %) while 44 % recorded by a continuous knife peeler represents the highest and worst loss. The throughput capacity for the peelers ranges from 6.2 – 1440 kg/h.

All these researchers have contributed to the search for an effective peeler by processors. However, the impact of these mechanical methods of peeling is still yet to be felt, especially among small-scale processors. It is, therefore, necessary for further studies to be conducted in determining the extent of adoption of these peelers as well as the expectations of processors of an acceptable peeler.

### Effectiveness of peelers and performance indicators

Peeling of cassava for various products can be done to various degrees. While food and high quality products like cassava dough, gari and high quality cassava flour (HQCF) require complete removal of the peels, other products like bioethanol and adhesives may not need total removal of the peels. Olukunle and Akinnuli (2013) stated that peel retention in the range of 5.7 % to 16 % would not affect the process of starch production, however, product quality in terms of taste and colour of high-grade cassava flour and gari are affected by peel retention. This suggests that the definition of effective peeling may be relative, depending on the end use of the cassava and further research may be needed to verify this. This notwithstanding, it is generally expected that peeling results in the complete removal of the whole peel (periderm and cortex) from the cassava flesh.

According to Olukunle and Akinnuli (2012), an effective peeler is one that has the ability to peel most sizes, weights and shapes of cassava roots efficiently with a very minimal level of cassava flesh loss. Odigboh (1976) also indicated that the

**Table 1** Operational and performance parameters of some mechanical cassava

Source	Mechanism	Mode of feeding	Speed (rpm)	Peeling Efficiency (%)	Flesh loss (%)	Throughput capacity (kg/h)
Olukunle and Akinnuli (2012)	Knife	Continuous	100 - 600	60.00 - 75.00	12.00 - 44.00	76.0 - 442.0
Ebunilo <i>et al.</i> (2013)	Lathe principle	Batch	180	70.00 - 92.00	-	-
Olukunle and Akinnuli (2013)	Abrasive	Continuous	500 - 3000	83.80 - 88.50	-	-
Oluwole and Adio (2013)	Abrasive	Batch	364 - 394	60.22 - 70.34	5.09 - 5.95	30.2 - 43.2
Ugwu and Ozioko (2015)	Abrasive	Continuous	380 - 460	70.00	-	-
Aji <i>et al.</i> (2016)	Abrasive	Continuous	1150	66.20	8.52	403.2
Jimoh <i>et al.</i> (2016)	Knife	Continuous	140 - 160	81.24 - 94.60	1.57 - 11.19	248.3 - 1046.5
Ogunlowo <i>et al.</i> (2016)	Knife	Continuous	40 - 60	55.00 - 95.00	-	-
Chilakpu (2017)	Abrasive	Batch	1500	97.00	8.00	700.0 - 1000.0
Pius and Nwigbo (2017)	Abrasive and Knife	Continuous	72	70.60	-	-
Adekunle <i>et al.</i> (2018)	Abrasive	Batch	400	80.87	10.09	106.3
Alhassan <i>et al.</i> (2018)	Abrasive	Batch	58	12.70 - 74	5.00 - 12.00	6.2 - 31.0
Sumaria and Tan (2018)	Water-jet and Knife	Batch	-	100.00	0.00	21.7 - 25.7
Alli and Abolarin (2019)	Abrasive	Continuous	50 - 250	80.90	-	47.9
Okoronkwo <i>et al.</i> (2019)	Abrasive	Batch	784	91.72	-	582.0
Olayanju <i>et al.</i> (2019)	Abrasive	Batch	144	63.64 - 68.97	22.38 - 37.5	104.4 - 223.2
Pariyed <i>et al.</i> (2019)	Knife	Batch	70 - 90	90.30	3.63	-
Barati <i>et al.</i> (2019)	Abrasive	Continuous	550 - 1150	99.50	19.00	-
Oyedele <i>et al.</i> (2019)	Abrasive	Batch	-	51.67-77.75	-	-
Onyenobi and Ikenga (2019)	Abrasive	Batch	-	80.00	-	-
Edeh <i>et al.</i> (2020)	Abrasive	Batch	40	75.40	5.88	119.0
Amanor and Bobobee (2020)	Abrasive	Batch	250 - 500	17.71-83.85	1.90 - 38.08	80.0 - 1440.0
Fadeyibi and Ajao (2020)	Abrasive	Batch	350 - 750	41.40 - 63.80	20.00 - 22.00	60.0 - 100.0

optimum peeling performance that can be expected of cassava peeling equipment is obtained when total removal of the peel is achieved without removal of the useful flesh. However, due to the varied differences between the physical and mechanical properties of cassava roots, achieving this task is very difficult (Tobiloba *et al.*, 2019). This means that, in an attempt to achieve total removal of the peels, there is a high tendency of experiencing an increase in the level of flesh loss. Odigboh (1976) also asserted that it is more economical to tolerate some level of flesh loss without the need for hand trimming than undertaking hand trimming after machine peeling. The unanswered question which remains, however, is, what level of flesh loss will be tolerable by the various processors of different cassava products?

In evaluating the performance of cassava peelers, some indicators are employed. Notable among these indicators are peel removal efficiency also referred to as peeling efficiency, percentage flesh loss and machine throughput capacity. Other parameters are the peeling quality index (which is a function of other performance indicators) and overall efficiency (for machines which perform multiple operations) (Aji *et al.*, 2016; Amanor and Bobobee, 2020; Ogunlowo *et al.*, 2016). These parameters are mostly influenced by some crop factors like moisture content, root size, peel thickness, days after harvest and maturity stage as well as machine factors like peeling drum speed, conveyor speed and feed rate or tuber loading.

### Peeling efficiency

Peeling efficiency or peel removal efficiency expresses the success of the peeler at removing all the peels from the cassava flesh. It is mostly expressed in percentage terms and is a measure of the proportion by mass of peels the machine can remove compared with that expected to be removed (Abdulkadir, 2012). Mathematically, peeling efficiency is determined by using equation (1).

$$\text{Peeling efficiency (\%)} = \frac{\text{Mass of peels removed by machine}}{\text{Total mass of peels}} \times 100 \quad (1)$$

Usually, the amount of peels expected to be removed or the flesh-to-peel ratio is initially determined through careful manual peeling before undertaking machine peeling or evaluation. This is because manual peeling (especially by the unwrapping method) is known to have a peeling efficiency of 100 % (Adetan *et al.*, 2006; Edeh *et al.*, 2020). As with all machines, the higher the peeling efficiency, the better the peeler. The ideal expectation is to achieve 100 % peeling even though this is very difficult to attain due to the differences in properties among the roots (Tobiloba *et al.*, 2019). Peeling efficiencies reported by the papers reviewed in this document ranged from 12.7 % to 100 % for various machine and crop parameters.

From research, one factor that influences the peeling efficiency of most peeling machines is the speed of the peeling mechanism and that of the conveying mechanism (auger) (Fadeyibi and Ajao, 2020; Nathan *et al.*, 2017; Olukunle and Akinnuli, 2013). How fast the peeling mechanism moves affects the nature of the interaction between it and the cassava roots. Most abrasive batch peelers reported that an increase in the speed of the peeling drum or disc results in an increase in peeling efficiency (Amanor and Bobobee, 2020; Fadeyibi and Ajao, 2020; Oluwole and Adio, 2013; Singh and Shukla, 1995). This account is supported by the report of Balami *et al.* (2016) and Barati *et al.* (2019) who worked on continuous abrasive peelers which do not employ an auger for conveyance.

However, Akintunde *et al.* (2005) and Oluwole and Adio (2013) worked on abrasive batch peelers and reported that a lower speed of rotation of the peeling machine will increase the peeling efficiency. In the latter reports, two abrasive concentric drums were employed in the design of both peelers, where the

cassava is worked on in-between these drums. This configuration might have influenced the performance of the peelers with respect to speed.

On the other hand, peeling efficiency for abrasive continuous peelers, which use augers in transporting the roots, is reported to decrease with an increase in the speed of the peeling drum (Alli and Abolarin, 2019; Nathan and Udosen, 2017). Also, Olukunle and Jimoh (2012) and Nathan *et al.* (2017) corroborate this finding that peel retention (which is the opposite of peel removal efficiency) increases with an increase in the speed of operation of the peeler. The reason given for this observation is that increase in speed leads to displacement of the cassava roots from the peeling tool and, also, results in a shorter contact period between the cassava and the peeling tool. In such designs, the contact period between cassava roots and the peeling member is controlled by the auger, which is mostly driven by power from the peeling shaft. An increase in the speed of the peeling shaft, therefore, results in a corresponding increase in conveyor speed, leading to the fast evacuation of the cassava from the machine. This analogy is confirmed by the account of Olukunle and Akinnuli (2013) in which conveyor speed and peeling tool speed were varied. They reported that peeling efficiency decreased as conveyor speed increased but increased as peeling brush speed increased. This means that independent of conveyor speed, peeling efficiency is likely to increase with an increase in peeling drum speed. This is because of the higher shear force created at higher speeds of the peeling drum (Olukunle and Akinnuli, 2013).

Pariyed *et al.* (2019) reported an increase in peeling efficiency with increase in the speed of the tuber knife peeling unit they developed. Olukunle and Akinnuli (2012) also reported that peeling efficiency gradually increased as machine speed for a continuous knife peeler increased from 100 rpm to 600 rpm (for big cassava sizes of length between 220 to 300 mm) but increased from 100 – 300 rpm speed and then decreased from 300 – 600 rpm (for small sizes of length between 100 to 220 mm). The trend reported for the small cassava roots has been confirmed by other researchers for knife peelers. Ogunlowo *et al.* (2016) reported that peeling efficiency increased with an increase in speed from 40 to 50 rpm but then decreased as speed increased from 55 to 60 rpm. The sizes of cassava used in this study were in the range of 100-310 mm in length. Jimoh *et al.* (2016) again reported that peeling efficiency slightly increased at lower speeds (100 – 120 rpm) but decreased at higher speeds between 130 – 140 rpm for the smooth-edged cutting tool. For the serrated-edged cutting tool, efficiency increased as speed increased from 140 – 160 rpm. This means for knife peeling machines, there is the need to determine the optimum speed at which peeling efficiency will be highest.

Concerning tuber loading (also known as feed rate or drum fill), Ogunlowo *et al.* (2016) and Alhassan *et al.* (2018) reported that an increase in tuber loading resulted in a decrease in peeling efficiency. This may be because an increase in fill results in reduced contact between the cassava roots and the peeling unit (Alhassan *et al.*, 2018). In contrast to this account, other researchers reported an increase in peeling efficiency for a corresponding increase in tuber loading (Adekunle *et al.*, 2018; Olayanju *et al.*, 2019). Olayanju *et al.* (2019) stated that this increase is due to higher interaction among the tubers. Further research will therefore be needed to determine the

factors that may be responsible for either an increase or decrease in peeling efficiency with respect to tuber loading.

Properties such as size, shape, peel thickness and moisture content of cassava roots influence the peeling efficiency of mechanical peelers. Peeling efficiency increases with an increase in the size of cassava roots but decreases with an increase in peel thickness (Ademosun *et al.*, 2012; Olukunle and Akinnuli, 2012). Cassava shape, size and peel thickness are influenced by factors such as variety, maturity stage, soil and climatic conditions, and tillage practices. To reduce the effects of size and shape and improve the performance of mechanical peelers, cassava roots are usually cut into appropriate sizes and sorted into different size ranges before peeling (Olukunle and Akinnuli, 2013). Such size categorisation is usually based on length or diameter. Peel thickness is reported to increase with an increase in cassava root diameter and also varies at the proximal, middle and distal portions of the root (Adetan *et al.*, 2003). Peeling efficiency was reported to increase with an increase in moisture content (Alli and Abolarin, 2019; Olukunle and Akinnuli, 2013). The moisture content of cassava roots is influenced by maturity stage, climatic conditions, days after harvest and variety. As moisture content reduces, the adhesion force between the peel and cassava flesh increases leading to a reduction in peeling efficiency (Olukunle and Akinnuli, 2013). Therefore, Olukunle and Akinnuli (2013) and Ogunlowo *et al.* (2016) reported that peeling efficiency decreased with an increase in the number of days after harvest of the cassava. This was due to the loss of moisture as the days after harvest increased. To improve the efficiency of mechanical peeling, breeding of cassava varieties with a regular shape is encouraged.

### **Tuber flesh loss**

Another parameter that greatly affects the performance of cassava peelers is tuber flesh loss. This is an expression of the proportion of useful cassava flesh which is lost with the peels as peeling takes place. Mathematically, it is the mass of cassava flesh removed along with the peel expressed as a percentage of the total mass of cassava flesh. The lower the level of flesh loss, the better the performance of the equipment and vice versa. Ideally, the expectation is no (0 %) flesh loss even though this is not easily achievable due to the irregular nature of the cassava roots. Reported records of flesh loss by the literature reviewed in this study range from 0 % to 44 % for various machine operation conditions and crop factors.

Tuber flesh loss is affected by the speed of operation of the peeling unit. Many researchers have reported that an increase in speed of operation increases tuber flesh loss (Amanor and Bobobee, 2020; Barati *et al.*, 2019; Jimoh and Olukunle, 2012; Oluwole and Adio, 2013; Pariyed *et al.*, 2019). According to Jimoh and Olukunle (2012), the increase in flesh loss is a result of an increase in interaction between the peeling unit and the cassava root. Fadeyibi and Ajao (2020) however reported that flesh loss increased with an increase in speed for sweet potato and yam, while it decreased with an increase in speed for cassava and cocoyam.

Tuber flesh loss is also affected by drum fill or tuber loading. The quantity of cassava in the peeling chamber influences the level of flesh loss experienced because it affects the level of interaction between the peeling tool and the cassava roots. Working with horizontal batch abrasive peelers,

Adekunle *et al.* (2018) and Alhassan *et al.* (2018) reported that an increase in drum fill increases flesh loss. Okoronkwo *et al.* (2019) working with a vertical batch abrasive peeler also reported a similar trend. In disagreement with this trend, Olayanju *et al.* (2019) reported that in working with a vertical batch abrasive peeler, an increase in tuber loading resulted in a decrease in flesh loss. They opined that this decrease was a result of more roots having continuous contact with the peeling surface per time.

It has been reported by Adetan *et al.* (2005) that abrasive peeling results in the grating of smaller cassava roots while bigger ones remain unpeeled. They indicated that to achieve acceptable peeling, the abrasive peelers reduce cassava roots to uniform cylindrical shapes leading to a high level of flesh loss. This is due to the irregular shapes and sizes of the cassava roots. This assessment suggests a direct relationship between peeling efficiency and flesh loss in abrasive peelers such that, the higher the peeling efficiency (due to prolonged peeling time), the higher the flesh loss and vice versa.

### Throughput capacity

Throughput capacity refers to the quantity of cassava peeled within a unit of time. It is mostly expressed in kilograms of cassava peeled per hour (kg/h) and indicates the rate at which the cassava peeler operates. Mathematically, it is determined using equation (2).

$$\text{Throughput capacity (kg/h)} = \frac{\text{Mass of cassava peeled}}{\text{Time taken to peel}} \quad (2)$$

Since cassava is highly perishable, expedited processing is greatly encouraged to reduce postharvest loss. Peeling machines with high throughput capacities are therefore preferred, especially for commercial processing operations. The literature reviewed in this study reported throughput capacities in the range of 6.2-1440 kg/h.

Generally, throughput capacity has been reported to increase with an increase in both speed of operation and tuber loading (Adekunle *et al.*, 2018; Alhassan *et al.*, 2018; Olukunle and Akinnuli, 2012). Jimoh *et al.* (2016) also reported that throughput capacity increased with an increase in speed and weight of cassava peeled for both serrated and smooth-edged knife peeling machines. The reason for this pattern is that, since throughput capacity is a function of the weight of cassava and peeling time, increasing the tuber loading or reducing the peeling time (which can be achieved by increasing the speed, especially in continuous peelers) will increase the throughput capacity (Jimoh *et al.*, 2016). Concerning the size of cassava roots, Olukunle and Akinnuli (2012) reported that throughput capacity increases with an increase in size while Jimoh *et al.* (2014) stated that the size of roots is inversely proportional to peeling time (which is inversely proportional to throughput capacity). This means cassava roots of small sizes will take a longer time to peel and therefore result in lower throughput capacity. This longer duration for peeling will also produce high tuber flesh loss.

Considering the performance indicators discussed, a peeler will need to be evaluated to determine the optimal conditions for its operation. Even though it has been reported that increasing peeling drum speed may increase peeling efficiency and throughput capacity, it must be noted that it may also

increase tuber flesh loss, which is undesirable. Therefore, the optimal machine conditions at which peeling efficiency, tuber flesh loss and throughput capacity are acceptable must be determined through the performance evaluation of mechanical peelers.

### Adoption of mechanical cassava peelers

Adoption refers to the integration of a new technology into an existing way of doing things (Ehinmowo and Fatuase, 2016; Melesse, 2018; Udimal *et al.*, 2017). Technology adoption, therefore, happens at the individual or single unit level and when it spreads through a potential target group over time, it is termed aggregate adoption or diffusion (Ehinmowo and Fatuase, 2016; Straub, 2009). Adoption requires that the adopters make a decision based on certain factors and they may choose to discontinue the use of that technology anytime depending on their level of satisfaction with it (Melesse, 2018; Wole-Alo and Olaniyi, 2015). Rogers (1995) and Straub (2009) discussed that an individual goes through these five stages in evaluating a technology in the adoption decision process; awareness, persuasion, decision, implementation and confirmation. Factors that influence the adoption of a technology have been broadly classified into three, namely; technology or innovation related factors, social or user related factors and institutional factors (Akudugu *et al.*, 2012; Melesse, 2018; Straub, 2009). Each of these factors is composed of a number of elements depending on the context and the type of technology being considered. It is generally recognised that technologies that are simple to understand and use are easily adopted and vice versa (Ehinmowo and Fatuase, 2016; Wole-Alo and Olaniyi, 2015). Ehinmowo and Fatuase (2016) reported that the mechanical grater was the most adopted technology among women processors because grating cassava was a necessity before all other processing operations.

As indicated earlier, even though several mechanical cassava peelers have been developed by various researchers and organisations, the level of adoption of mechanical peeling by small and medium-scale processors is very low. It has been reported that unsatisfactory performance of the peelers might be the main reason for this situation (Egbeocha *et al.*, 2016; Tobiloba *et al.*, 2019); hence, the continuous search for an effective peeler. This notwithstanding, there is the need for further research, which might lead to discovering other equally important factors hindering the adoption of mechanical peelers. In the study by Ehinmowo and Fatuase (2016), it was reported that the mechanical peeler was the least adopted technology by women processors in South-West Nigeria. The reasons for this were that there was a lack of understanding of the technicality of the peeler and, also, the manual peeling had better efficiency than the peelers they had access to.

Availability and cost of labour if favourable can influence the choice of manual peeling over mechanical peeling. Under such circumstances, the adoption of mechanical peeling especially by small-scale processors will continue to suffer rejection until the cost for manual labour increases or there is a shortage of labour for the operation (Pingali, 2007; Wang *et al.*, 2016; Yamauchi, 2016). Another possible reason for the non-adoption of mechanical peelers could be the low volumes of cassava processed per person, resulting from limited demand for the processed products. This means if the market for processed cassava products increases, higher volumes will

need to be processed, creating the need for mechanical peeling. This is similar to the situation discussed regarding the adoption of mechanical threshing in sub-Saharan Africa by Pingali (2007). One more important possible cause of the continuous use of manual peeling by small and medium-scale cassava processors could be the high investment cost requirement of mechanical peelers (Ehinmowo and Fatuase, 2016; Odebode, 2008). Individual processors usually do not have the financial capacity to purchase a peeler alone. This means investment in purchasing and operation (on a charge-per-run basis) of mechanical peelers will need to be done by interested investors or entrepreneurs with that financial ability, as has been applied to the adoption of milling and other postharvest processing operations (Pingali, 2007). Furthermore, lack of information on and inaccessibility to mechanical peelers developed by researchers can hinder the adoption of the technology (Ehinmowo and Fatuase, 2016; Odebode, 2008). Effort is needed at disseminating the technology to end users. Additional possible challenges could be difficulty in operating the machines, heavy weight of machines and lack of essential infrastructural facilities to support the operation of the mechanical peelers (Odebode, 2008)

Abass *et al.* (2017) indicated that mechanising cassava processing at the right scale can produce immense benefits for the cassava industry, especially for the large population of smallholder farmers in Africa. It will lead to increased demand for cassava, which will translate into higher incomes, increased yields and improved production efficiencies. Since manual peeling is a major bottleneck in the mechanisation of cassava processing, frantic effort is needed toward the development, promotion, adoption and diffusion of efficient peelers to boost the sector. This will require collaboration among researchers, processors, government institutions, funding institutions, entrepreneurs and other stakeholders (Kolawole *et al.*, 2010; Wole-Alo and Olaniyi, 2015).

## Conclusions

Four common methods of peeling, namely manual, steaming, chemical and mechanical methods were identified, among which manual and mechanical are mostly used in cassava processing. The manual method of peeling though efficient, is time-consuming, low yielding and involves much drudgery; hence, not favourable for commercial processing of cassava.

Mechanical peelers can be classified based on the type of peeling mechanism employed (abrasive, knife or lathe) or mode of feeding/discharge of the cassava (batch or continuous). The abrasive peeling mechanism is the most common among the peeling equipment reviewed because of its ease of operation, ease of manufacture and the numerous abrasive surfaces that can be employed. Performance of the abrasive peelers reviewed ranged from 12.7 – 99.5 % for peeling efficiency and 1.9 – 42.7 % for percentage flesh loss while that for knife peeling equipment was 15.2 – 94.6 % for peeling efficiency and 1.57 – 44 % for flesh loss. Also, peeling efficiency for the lathe peeling equipment was 70 – 90 %. Only the waterjet-assisted peeler recorded 100 % peeling efficiency and 0 % flesh loss even though it had a low capacity of 21.68 – 25.68 kg/h due to the mode of feeding (one root at a time) and requires, relatively, a lot of water for its operation. Pre-treatment of cassava by freeze-thaw method before mechanical peeling resulted in the highest peeling efficiency of 99.5% for abrasive peelers.

Generally, peeling efficiency in abrasive peelers increases with an increase in peeling drum speed for batch peelers and others without conveyors while it decreases with an increase in speed of peeling drum in peelers with conveyors driven by the peeling drum due to a decrease in retention time. Again an increase in peeling drum speed results in an increase in tuber flesh loss as reported by most of the peeling machines reviewed. Throughput capacity also increases with an increase in the speed of operation of the peeling drum. Unsatisfactory performance and lack of understanding of the technicalities of mechanical peelers have been cited as possible reasons for their non-adoption by processors.

Based on these conclusions, it is recommended that even though a massive contribution has been made by various researchers, the search for an effective and acceptable peeler continues and further research is required. However, future research may focus on improving the use of the abrasive peeling mechanism since it is easier to design and work with. In addition to developing peelers based on the physical and mechanical properties of cassava, researchers may need to also consider in their engineering designs the expectations of processors with respect to an effective peeler to enhance adoption. This calls for engagement with these processors as part of the engineering design process. To better understand and deal with the non-adoption of mechanical peelers, further research is needed to identify all the persisting constraints surrounding the situation. Research on the cost-benefit analysis of mechanical peeling can be explored to inform processors and investors about the viability or otherwise of the technology. Ultimately, the adoption of mechanical peeling will boost the local cassava processing industry; hence, the effort and collaboration of various stakeholders is greatly encouraged.

## Conflict of Interest Declarations

The authors declare that there is no conflict of interest.

## References

- Abass, A., Amaza, P., Bachwenkizi, B., Wanda, K., Agona, A. and Cromme, N. (2017). The impact of mechanized processing of cassava on farmers' production efficiency in Uganda. *Applied Economics Letters*, 24(2), pp. 102–106.
- Abdulkadir, B.H. (2012). Design and Fabrication of a Cassava Peeling Machine. *IOSR Journal of Engineering*, 02(06), pp. 01–08.
- Adekunle, A.S., Ohijeagbon, I.O., Kareem, A.A., Taiwo, Y., Jilantikiri, L.J., Sadeeq, A. and Olusegun, H.D. (2018). Development and performance evaluation of cassava peeling machine. *Adeleke University Journal of Engineering and Technology*, 1(1), pp. 66–80.
- Ademosun, O.C.C., Jimoh, M.O.O. and Olukunle, O.J.J. (2012). Effect of physical and mechanical properties of cassava tubers on the performance of an automated peeling machine. *International Journal of Development and Sustainability*, 1(3), pp. 810–822.
- Adetan, D.A., Adekoya, L.O. and Aluko, O.B. (2003). Characterisation of some properties of cassava root tubers. *Journal of Food Engineering*, 59, pp. 349–353.
- Adetan, D.A., Adekoya, L.O. and Aluko, O.B. (2006). Theory of a mechanical method of peeling cassava tubers with knives. *International Agrophysics*, 20(4), pp. 269–276.

- Adetan, D.A., Adekoya, L.O., Aluko, O.B. and Makanjuola, G.A. (2005). An experimental mechanical cassava tuber peeling machine. *Journal of Agricultural Engineering and Technology*, 13, pp. 27–34.
- Aidoo, R., Boakye-Achampong, S., Wie, P. and Appiah, B.G. (2019). Root and tuber crops in Ghana - an overview. In: Aidoo, R., Agbenorhevi, J. K., Wireko-Manu, F. D. and Wangel, A., eds., *Roots and tubers in Ghana: overview and selected research papers*. Kumasi: College of Agriculture & Natural Resources, KNUST, pp. 1–22.
- Aji, I.S., Emmanuel, M.U., Abdulrahman, S.A. and Franklyn, O.F. (2016). Development of an electrically operated cassava peeling and slicing machine. *Arid Zone Journal of Engineering, Technology and Environment*, 12, pp. 40–48.
- Akintunde, B.O., Oyawale, F.A. and Tunde-Akintunde, T.Y. (2005). Design and fabrication of a cassava peeling machine. *Nigerian Food Journal*, 23, pp. 231–238.
- Akudugu, M.A., Guo, E. and Dadzie, S.K. (2012). Adoption of modern agricultural production technologies by farm Households in Ghana: what factors influence their decisions? *Journal of Biology, Agriculture and Healthcare*, 2(3), pp. 1–13.
- Alhassan, E.A., Ijabo, O.J. and Afolabi, E. (2018). Development of cassava peeling machine using an abrasive mechanism. *Journal of Production Engineering*, 21(1), pp. 61–66.
- Alli, O.D. and Abolarin, M.S (2019). Design modification of a cassava attrition peeling machine. *Journal of Physics: Conference Series*, 1378, pp. 1–11.
- Amanor, I.N. and Bobobee, E.Y.H. (2020). Evaluation of a motorized cassava peeler with four lining materials. *African Journal of Agricultural Research*, 16(10), pp. 1342–1354.
- Balami, A.A., Dauda, S.M., Mohammed, I.S., Agunsoye, J.K., Abu, H., Abubakar, I. and Ahmad, D. (2016). Design and fabrication of a cocoyam (*Colocasia esculenta*) peeling machine. *International Food Research Journal*, 23(Suppl), pp. S65–S70.
- Barati, Z., Latif, S., Romuli, S. and Müller, J. (2019). Freeze - thaw pre-treatment of cassava tubers to improve efficiency of mechanical peeling. *Applied Sciences*, 9(14), pp.1–13.
- Barati, Z., Latif, S., Romuli, S. and Müller, J. (2020). Enzyme-assisted mechanical peeling of cassava tubers. *Catalysts*, 10(66), pp. 1–14.
- Bobobee, E.Y.H. (2019). Mechanisation of cassava (root and tuber crops) production in Ghana. In: Aidoo, R., Agbenorhevi, J. K., Wireko-Manu, F. D. and Wangel, A., eds., *Roots and tubers in Ghana: overview and selected research papers*. Kumasi: College of Agriculture & Natural Resources, KNUST, pp. 413–442.
- Bobobee, E.Y.H. and Yakanu, P.N. (2018). Mechanised cassava production and harvesting on ridges – a conservation agricultural approach. Second Africa congress on conservation agriculture, Making climate-smart agriculture real in Africa with conservation agriculture - supporting the Malabo Declaration and Agenda 2063, Johannesburg, South Africa, 9-12 October 2018, pp. 227–232.
- Chilakpu, K. and Asoegwu, S.N.(2010). Design and fabrication of drum cassava peeling machine. *Raw Materials Research and Development Council Expo 2010*. Abuja.
- Chilakpu, K.O. (2017). Modification of a self-loading cassava peeling machine. *Futo Journal Series (FUTOJNLS)*, 3(1), pp. 273–279.
- Daniyan, I.A., Adeodu, A.O., Azeez, T.M., Dada, O.M. and Olafare A.O. (2016). Optimization of peeling time and operational speed for cassava peeling using central composite design and response surface methodology. *International Journal of Engineering Sciences & Research Technology*, 5(9), pp. 630–639.
- Davies, R.M., Olatunji, M.O. and Burubai, W. (2008). A survey of cassava processing machinery in Oyo State. *World Journal of Agricultural Sciences*, 4(3), pp. 337–340.
- Ebewore, S.O. and Isiorhovoja, R.A. (2019). Knowledge status and disease control practices of cassava farmers in Delta State, Nigeria: implications for extension delivery. *Open Agriculture*, 4, pp. 173–186.
- Ebomwomyi, P., Oroh, E.M., Sadjere, E.G. and Ariavie, G.O. (2017). Design of an improved cassava peeling machine. *International Journal for Research in Applied Science & Engineering Technology (IJRASET)*, 5(6), pp. 1718–1723.
- Ebunilo, P., Egbware, H. and Ukwuaba, S. (2013). Design and testing of an experimental cassava tuber peeling machine. *International Journal of Engineering Research in Africa*, 9, pp.35–42.
- Edeh, J.C., Nwankwojike, B.N. and Abam, F.I. (2020). Design modification and comparative analysis of cassava attrition peeling machine. *Agricultural Mechanization in Asia, Africa and Latin America*, 51(1), pp. 63–71.
- Egbeocha, C.C., Asoegwu, S.N. and Okereke, N.A. (2016). A review on performance of cassava peeling machines in Nigeria. *Futo Journal Series (FUTOJNLS)*, 2(1), pp.140–168.
- Ehinmowo, O.O. and Fatuase, A.I.(2016). Adoption of improved cassava processing technologies by women entrepreneur in south-west, Nigeria. *World Journal of Agricultural Research*, 4(4), pp. 109–113.
- Evuti, A.M., Folorunsho, A.D. and Joys, M. V. (2010). Optimization of some operating parameters for steam peeling of cassava tubers. *International Journal of ChemTech Research*, 2(3), pp. 1592–1597.
- Ezekwe, G.O. (1979). Mechanising cassava peeling: The PRODA cassava nibbling machine. *PRODA Tech Reports*, pp. 1-20
- Fadeyibi, A. and Ajao, O. (2020). Design and performance evaluation of a multi-tuber peeling machine. *AgriEngineering*, 2, pp. 55–71.
- FAOSTAT. (2019). Food and agriculture data. [online]. Available at: <http://www.fao.org/faostat/en/#data/QC> [Accessed 11 July 2020].
- Hou, Z.B. and Komanduri, R. (2003). On the mechanics of the grinding process - Part I. Stochastic nature of the grinding process. *International Journal of Machine Tools & Manufacture*, 43, pp. 1579–1593.
- Ibgebulem, C.O. and Chikezie, P.C. (2018). Comparative proximate composition and cyanide content of peeled and unpeeled cassava roots processed into garri by traditional methods. *Research Journal of Food and Nutrition*, 2(2), pp. 1–13.
- Ilori, O.O. and Adetan, D.A. (2013). A study of the peel penetration pressure of two cassava varieties. *Middle East Journal of Scientific Research*, 16(6), pp. 884–889.
- Ilori, O.O., Adetan, D.A., Soji-Adekunle, A.R., Ojo, O.O., Adeleke, K.M. and Towoju, O.O. (2017). Influence of some physical properties of cassava tubers on mechanical compressive cracking force of TMS 30572

- and TMS 4(2)1425 cassava varieties. *American Journal of Food Science and Technology*, 5(6), pp. 233–237.
- Jimoh, M.O. and Olukunle, O.J. (2012). An automated cassava peeling system for the enhancement of food security in Nigeria. *Nigerian Food Journal*, 30(2), pp.73–79. [http://dx.doi.org/10.1016/S0189-7241\(15\)30038-2](http://dx.doi.org/10.1016/S0189-7241(15)30038-2).
- Jimoh, M.O., Olukunle, O.J. and Manuwa, S.I. (2014a). Comparative analysis of cassava peeling concept of an automated system. *The West Indian Journal of Engineering*, 37(1), pp. 58–64.
- Jimoh, M.O., Olukunle, O.J. and Manuwa, S.I. (2016). Modeling of cassava peeling performance using dimensional analysis. *Agricultural Engineering International: CIGR Journal*, 18(2), pp. 360–367.
- Jimoh, M.O., Olukunle, O.J., Manuwa, S.I. and Amumeji, O.T. (2014b). Theoretical analysis of tuber movement during mechanical peeling of cassava. *IOSR Journal of Mechanical and Civil Engineering*, 11(6), pp. 27–36.
- Kamal, A.R. and Oyelade, O.A. (2010). Present status of cassava peeling in Nigeria. *Journal of Agricultural Engineering and Technology (JAET)*, 18(2), pp. 7–13.
- Kolawole, P.O., Agbetoye, L. and Ogunlowo, S.A. (2010). Sustaining world food security with improved cassava processing technology: The Nigeria experience. *Sustainability*, 2(12), pp. 3681–3694.
- Melesse, B. (2018). A Review on Factors Affecting adoption of agricultural new technologies in Ethiopia. *Journal of Agricultural Science and Food Research*, 9(3), pp. 1–6.
- Nathan, C. and Udosen, U.J. (2017). Comparative analysis of type 1 and type 2 cassava peeling machines. *Nigerian Journal of Technology*, 36(2), pp. 469–476.
- Nathan, C., Wadai, J. and Haruna, I.U. (2017). Comparative analysis of type 3 and type 4 cassava peeling machines. *Nigerian Journal of Technology*, 36(4), pp. 1088–1094.
- Odebode, S.O. (2008). Appropriate technology for cassava processing in Nigeria: User's point of view. *Journal of International Women's Studies*, 9(3), pp. 269–286.
- Odigboh, E.U. (1976). A cassava peeling machine: development, design and construction. *Journal of Agricultural Engineering Research*, 21, pp. 361–369.
- Ogunlowo, S., Olaleye, S.A. and Fasunla, M.S. (2016). Performance evaluation of the automated system for cleaning, peeling and washing cassava tubers. *Int'l Journal of Advances in Agricultural & Environmental Engg.*, 3(2), pp. 327–332.
- Ohwovoriole, E.N., Oboli, S. and Mgbeke, A.C.C. (1988). Studies and preliminary design for a cassava tuber peeling machine. *Transactions of the ASAE*, 31(2), pp. 380–385.
- Okoronkwo, C.A., Ezurike, B.O., Adjogbe, A.S. and Oguoma, O.N. (2019). The use of locally sourced materials in the design and analysis of a portable cassava peeling machine. *International Journal of Scientific & Technology Research*, 8(11), pp. 3122–3129.
- Olayanju, A.T., Isaac, M.O., Okonkwo, C.E., Alake, A.S. and Friday, M.G. (2019). Development of a ceramic cassava peeling-and-washing machine. *Mindanao Journal of Science and Technology*, 17, pp. 84–97.
- Olukunle, O.J. and Akinnuli, B.O. (2012). Performance evaluation of a single action cassava peeling machine. *Journal of Emerging Trends in Engineering and Applied Sciences*, 3(5), pp. 806–811.
- Olukunle, O.J. and Akinnuli, B.O. (2013). Theory of an automated cassava peeling system. *International Journal of Engineering and Innovative Technology*, 2(8), pp. 177–184.
- Olukunle, O.J. and Jimoh, M.O. (2012). Comparative analysis and performance evaluation of three cassava peeling machines. *International Research Journal of Engineering Science, Technology and Innovation*, 1(4), pp. 94–102.
- Oluwole, O.O. and Adio, M.A. (2013). Design and construction of a batch cassava peeling machine. *Journal of Mechanical Engineering and Automation*, 3(1), pp. 16–21.
- Onyenobi, S.C. and Ikenga, E. (2019). Design of a modernized cassava peeling machine. *International Journal of Innovative Science and Research Technology*, 4(10), pp. 656–664.
- Oriola, K.O. and Raji, A.O. (2013a). Trends at mechanizing cassava postharvest processing operations trends at mechanizing cassava postharvest processing operations. *International Journal of Engineering and Technology*, 3(9), pp. 879–887.
- Oriola, K.O. and Raji, A.O. (2013b). Effects of tuber age and variety on physical properties of cassava [*Manihot esculenta* (Crantz)] roots. *Innovative Systems Design and Engineering*, 4(9), pp.15–25.
- Osei, S. (2020). A Review on the performance of some cassava peeling machines developed. *North American Academic Research*, 3(02), pp. 97–162.
- Oyedele, S.T., Ngoddy, P.O., Kilanko, O. and Leramo, R.O. Design and fabrication of a wet mechanical brushing unit for lye pre-treated cassava root. *Journal of Physics: Conference Series*, 1378(2), pp. 1–12.
- Oyelade, O.A., Bamidele, B.L. and Ademiluyi, Y. S. (2019). Present status of the level of agricultural mechanization available for cassava processing operations in Ekiti State of Nigeria. *Continental J. Sustainable Development*, 10(1), pp. 14–21.
- Pariyed, S., Juckmas, L., Aphisit, P., Suphan, Y. and Cherdpong, C. (2019). Design and construction of a cassava tuber knife peeling unit. *The Journal of Industrial Technology*, 15(3), pp. 1–11.
- Pingali, P. (2007). Agricultural mechanization: adoption patterns and economic impact. In: Evenson, R. E. and Pingali, P., eds., *Handbook of agricultural economics*. 3rd ed. Amsterdam: Elsevier B.V., pp. 2779–2805.
- Pius, P. and Nwigbo, S. (2017). Design, fabrication, static and dynamic simulation of a cassava peeling machine. *International Journal of Recent Trends in Engineering and Research*, 3(11), pp. 283–288.
- Rogers, E. (1995). *Diffusion of innovations*. 4th ed. New York: Free Press
- Sagracao, J. and Tan, D.L. (2008). Effects of the mechanical factors on the peeling of cassava. *Annals of Tropical Research*, 30(1), pp. 72–92.
- Sajeev, M.S., Sreekumar, J., Unnikrishnan, M., Moorthy, S.N. and Shanavas, S. (2010). Kinetics of thermal softening of cassava tubers and rheological modeling of the starch. *Journal of Food Science and Technology*, 47(5), pp. 507–518.
- Shirmohammadi, M., Yarlagadda, P., Kosse, V. and Gu, Y. (2012). Study of mechanical deformations on tough skinned vegetables during mechanical peeling process (a review). *GSTF Journal of Engineering Technology*, 1(1), pp. 1–7.

- Singh, K.K. and Shukla, B.D. (1995). Abrasive peeling of potatoes. *Journal of Food Engineering*, 26(4), pp. 431–442.
- Straub, E.T. (2009). Understanding technology adoption: Theory and future directions for informal learning. *Review of Educational Research*, 79(2), pp. 625–649.
- Sumaria, R. and Tan, D.L. (2018). Development of waterjet-assisted assisted cassava peeler. *Annals of Tropical Research*, 40(2), pp. 124–134.
- Tobiloba, O., Oluwaseun, K. and Leramo, R.O. (2019). Performance of cassava peeling machines in Nigeria: a review of literature. *Journal of Physics: Conference Series*, 1378, pp. 1–17.
- Udimal, T.B., Jincal, Z., Mensah, O.S. and Caesar, A.E. (2017). Factors influencing the agricultural technology adoption: the case of improved rice varieties (nerica) in the northern region, Ghana. *Journal of Economics and Sustainable Development*, 8(8), pp. 137–148.
- Ugwu, K.C. and Ozioko, R.E. (2015). Development and performance test of cassava peeling and washing machine. *International Journal of Scientific and Engineering Research*, 6(6), pp. 1572–1579.
- Wang, X., Yamauchi, F. and Huang, J. (2016). Rising wages, mechanization, and the substitution between capital and labor: Evidence from small scale farm system in China. *Agricultural Economics*, 47(3), pp. 309–317.
- Wole-Alo, F.I. and Olaniyi, O.J. (2015). Utilization of modern cassava processing techniques among smallholder rural women processor in Ondo State, Nigeria. *Journal of Biology, Agriculture and Healthcare*, 5(12), pp. 28–33.
- Yamauchi, F. (2016). Rising real wages, mechanization and growing advantage of large farms: Evidence from Indonesia. *Food Policy*, 58, pp. 62–69. <http://dx.doi.org/10.1016/j.foodpol.2015.11.004>.