

## COMPARISON OF THE EMISSION PROPERTIES OF $\text{Ho}^{3+}:\text{KPb}_2\text{Cl}_5$ AND $\text{Ho}^{3+}:\text{CaF}_2$ CRYSTALS

Oyebola, O. O.<sup>1</sup>, Ogungbemi, K. I.<sup>1</sup> and Olopade, M. A.<sup>1</sup>

<sup>1</sup> Department of Physics, University of Lagos, Akoka-Lagos, Nigeria  
(Corresponding Author: ooyebola@unilag.edu.ng; adeolusola@gmail.com)  
(Received: 22<sup>nd</sup> April, 2015; Accepted: 7<sup>th</sup> July, 2015)

### ABSTRACT

Most laser gain media are characterized by emission quenching in the mid-IR wavelength region as a result of the high phonon structure of such media. The need for more emission in the mid-IR region has made the development of low phonon hosts a major research interest. In this work, we compared the infrared emission properties of  $\text{Ho}^{3+}$  doped low phonon halides ( $\text{KPb}_2\text{Cl}_5$ ) with those of their fluoride counterparts. Results show that mid-IR emission wavelengths that appeared in the halide hosts were effectively quenched in the fluorides. Furthermore, the emission lifetimes of the halides did not vary significantly with temperature, indicating that they were not susceptible to much non-radiative decay as it was found in high phonon crystals.

**Keywords:** Lasers, Fluorescence, Lifetime, Multi-phonon Relaxation, Radiative Decay, Mid-IR Emission Quenching.

### INTRODUCTION

The mid infrared wavelength region has lately become important for several portable applications (Joullie *et al.*, 2003). This has turned research attention to the development of portable lasers that can operate in the mid-IR wavelength region (Kalisky, 1999). Available mid-IR lasers are either too bulky for portable application or they require cryogenic cooling, making them unsuitable for outdoor use (Tittel *et al.*, 2007). The viable alternative is to develop portable diode-pumped solid state (DPSS) lasers. Trivalent lanthanide ions ( $\text{Ln}^{3+}$ ) have been found to produce emission from UV to IR wavelength range when embedded in suitable hosts (Diening *et al.*, 1997). The challenge however is the quenching of mid infrared emission experienced in several hosts as a result of their high phonon structure, which makes them susceptible to high multi-phonon relaxation processes (Heo, 1997). Of current research interest is the development of suitable low phonon hosts that will allow emission in the mid-IR wavelength region (Schneider *et al.*, 1997). Such novel materials are found in the halide family and of particular interest are potassium lead chloride ( $\text{KPb}_2\text{Cl}_5$ ) and potassium lead bromide ( $\text{KPb}_2\text{Br}_5$ ) with maximum phonon energy of  $\sim 203 \text{ cm}^{-1}$  and  $\sim 140 \text{ cm}^{-1}$  respectively (Isaenko *et al.*, 2002). Literature abounds on the synthesis and properties of these halides as host matrices for  $\text{Ln}^{3+}$  ions (Rademaker *et al.*, 2005; Nostrand *et al.*,

2001; Isaenko *et al.*, 2001). In this paper, we compared the spectroscopy of  $\text{Ho}^{3+}:\text{KPb}_2\text{Cl}_5$  ( $\hbar\omega_{\text{max}} \sim 203 \text{ cm}^{-1}$ ) with that of  $\text{Ho}:\text{CaF}_2$  ( $\hbar\omega_{\text{max}} \sim 500 \text{ cm}^{-1}$ ) to see the effect of the phonon structure of the host matrix on mid-IR emission.

### MATERIALS AND METHOD.

The details of the material synthesis and growth of  $\text{Ho}^{3+}:\text{KPb}_2\text{Cl}_5$  and  $\text{Ho}^{3+}:\text{CaF}_2$  have been described elsewhere (Oyebola *et al.*, 2010).  $\text{Ho}^{3+}$  absorption peaks were obtained from transmission studies carried out with a Cary 5000 UV-VIS-NIR spectrophotometer and corresponding absorption coefficients deduced using the Beer-Lambert law.

Spectral emission measurements were carried out using the schematic setup shown in Figure 1. The laser beam from the pump source was focused on the sample through the lens and mirror arrangement. An optical chopper was placed in the line of the excitation beam for modulation of the CW laser. The emission produced by the sample was then collected and focused through another lens arrangement into the spectrometer. An appropriate long pass filter was placed at the entrance slit of the spectrometer to block unwanted signals. The signal collected by the detector was sent to the oscilloscope for display and to the computer through a lock-in amplifier

for data analysis. Samples were excited and scanned over the (750 -1750 nm) near infrared (NIR) region and the (1800 – 4500 nm) mid infrared (MIR) region. For time-resolved experiments, the setup was similar to Figure 1, except that the pump source was replaced with a pulsed laser, and there was no need for a modulating chopper. The transients of the various NIR emission peaks were captured on the

oscilloscope and their data recorded for lifetime analysis. Temperature dependent emission and lifetime studies were also carried out on the samples. For temperature dependent measurements, the sample mount was enclosed inside a closed cycle helium refrigerator that reduced the temperature of the sample to as low as 10 K.

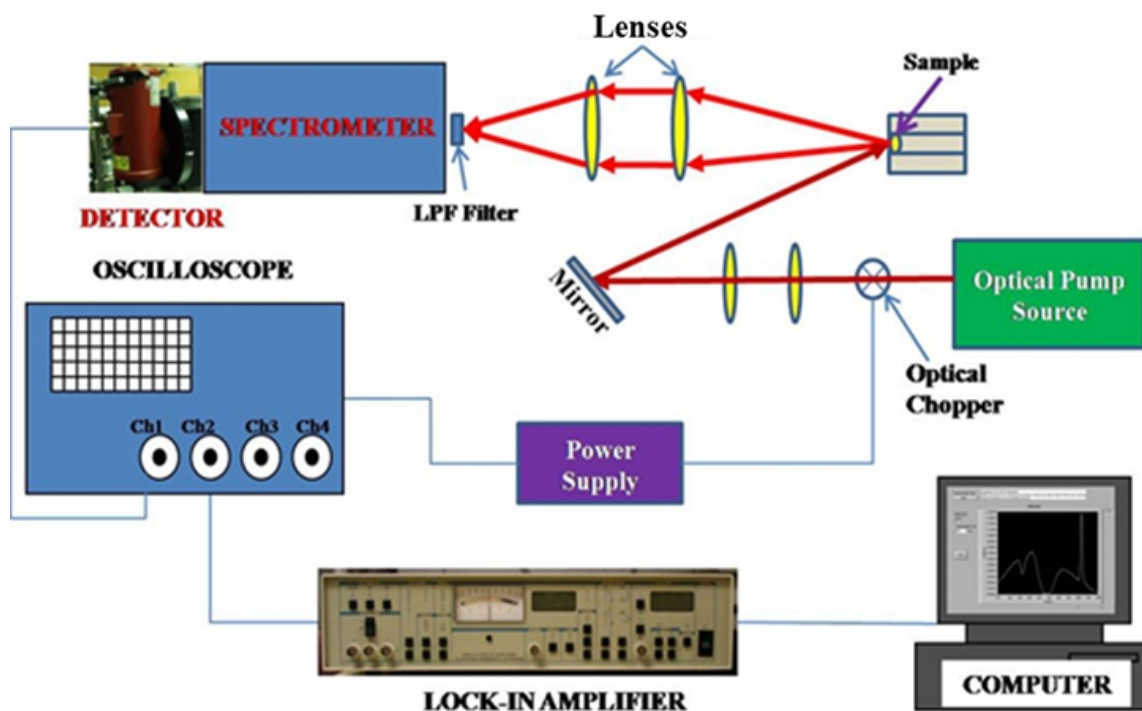

Figure 1. Schematic Setup For Spectral Emission Measurements.

## RESULTS AND DISCUSSION

The efficacy of low phonon hosts in producing mid-IR emission was clearly demonstrated by the comparison of emissions from  $\text{Ho}^{3+}:\text{KPC}$  and  $\text{Ho}^{3+}:\text{CaF}_2$  ( $\hbar\omega_{\text{max}} \sim 500 \text{ cm}^{-1}$ ) as shown in Figure 2. While the  $1.6 \mu\text{m}$  emission from the  $^5\text{I}_5$  excited state is intense in  $\text{Ho}^{3+}:\text{KPC}$ , it is almost completely quenched in  $\text{CaF}_2$ . Similarly, the  $3.9 \mu\text{m}$  mid-IR emission, also from the  $^5\text{I}_5$  excited state is intense in  $\text{Ho}^{3+}:\text{KPC}$  and almost completely

quenched in  $\text{Ho}^{3+}:\text{CaF}_2$ . At the same time, the  $2.9 \mu\text{m}$  emission is very strong in  $\text{Ho}^{3+}:\text{CaF}_2$  but almost entirely quenched in  $\text{Ho}^{3+}:\text{KPC}$ .

This observation is consistent with the energy gap law (Kaminskii, 1996) as illustrated in Figure 3. The energy gap between the  $^5\text{I}_5$  and the  $^5\text{I}_6$  levels is  $\sim 2500 \text{ cm}^{-1}$ . For the calcium fluoride, this is an energy gap of about five phonons while in the potassium lead chloride over twelve phonons are required to fill the same energy gap.

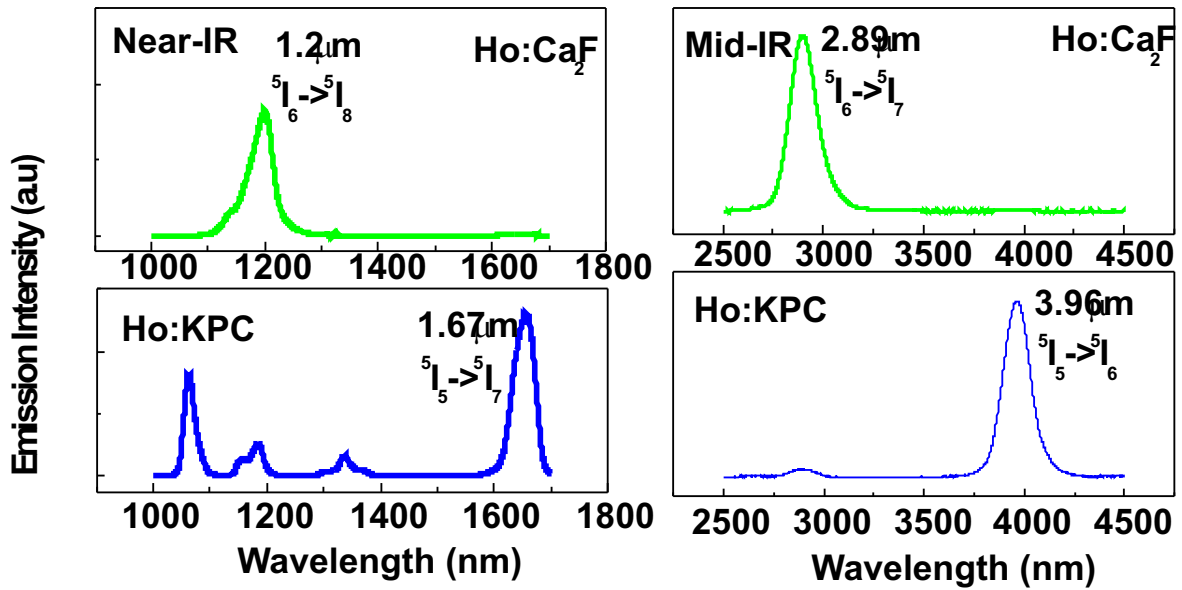

Figure 2. Comparison of Near-IR and Mid-IR Emissions in  $\text{Ho}^{3+}:\text{KPC}$  and  $\text{Ho}^{3+}:\text{CaF}_2$ , Showing the Quenching of the  $^5\text{I}_5$  Transitions From  $\text{Ho}^{3+}:\text{CaF}_2$ .

Hence the KPC host allows radiative transitions of 1.6  $\mu\text{m}$  to the  $^5\text{I}_7$  level and 3.9  $\mu\text{m}$  transition to the  $^5\text{I}_6$  level, whereas in the calcium fluoride host, these emissions are quenched because of multi-

phonon relaxation process from the  $^5\text{I}_5$  to the  $^5\text{I}_6$  level so that strong 1.2  $\mu\text{m}$  and 2.9  $\mu\text{m}$  emission are observed in  $\text{Ho}^{3+}:\text{CaF}_2$ .

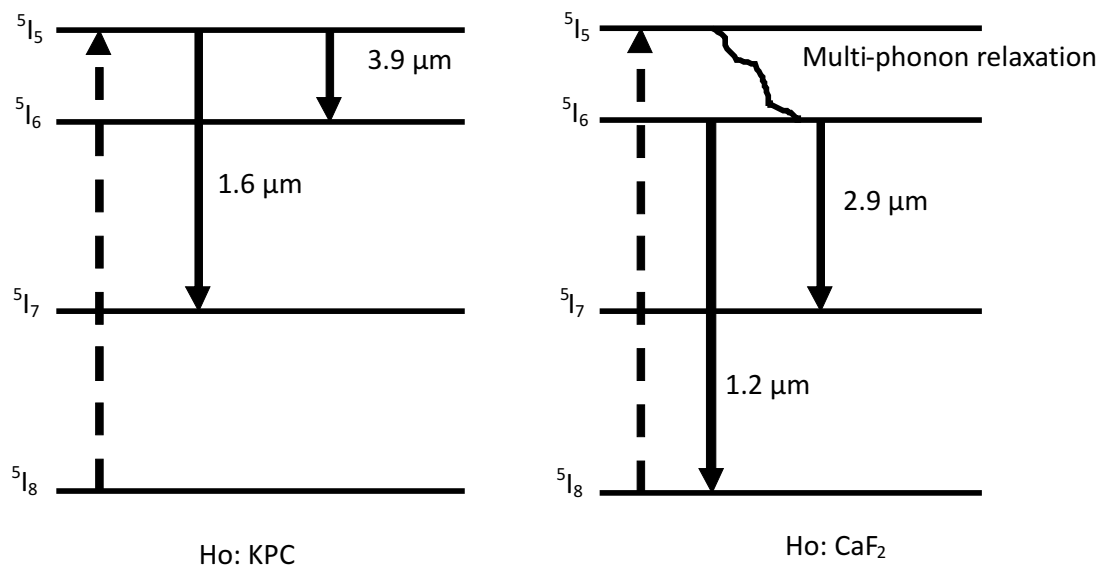

Figure 3. Comparison of The Dominant IR Transitions in  $\text{Ho}:\text{KPC}$  and  $\text{Ho}:\text{CaF}_2$ .

Temperature dependent lifetime measurements of the <sup>5</sup>I<sub>5</sub> level were carried out for Ho<sup>3+</sup>:KPC and monitored at ~ 1.7 μm for temperatures between 10K and 300K (to room temperature) in order to determine the extent of non-radiative decay occurring from that level.

The experimental lifetime is a combination of the radiative and non-radiative lifetimes and the non-radiative decay rate is usually expressed in the form of multi-phonon relaxation (MPR) processes (Pujol *et al.*, 2002). Multi-phonon relaxation processes are generally expected to reduce at low temperatures due to a reduction in lattice vibrations (Orlovskii *et al.*, 2002). Therefore, a noticeable temperature dependence of the measured lifetime, especially significantly longer measured lifetimes at low temperatures may indicate considerable emission quenching at room temperature arising from multi-phonon relaxation (Brown *et al.*, 2007). The temperature dependent decay transients of the <sup>5</sup>I<sub>5</sub> level in the Ho<sup>3+</sup>:KPC crystal for representative temperature values (10K, 150K and 300K) is shown in Figure 4 while the variation lifetime with temperature for the entire temperature range (10K ~ 300K) is shown in Figure 5. For hosts in which multiphonon relaxation is significant at room temperature, the

low temperature lifetime is usually greater than room temperature lifetime by a factor of ~5 (Brown *et al.*, 2007). Contrary to the expectation that the lifetimes of excited states should increase at low temperatures, the <sup>5</sup>I<sub>5</sub> level in the Ho<sup>3+</sup>:KPC shows an unusual but slight increase in lifetime towards room temperature. This phenomenon is not totally uncommon as it has been observed in other rare earth doped crystals. Eu<sup>2+</sup> doped CaF<sub>2</sub> was found to show increase in lifetime with increasing temperature from about 10K to room temperature (Duan *et al.*, 2006). It has been suggested that this reduction in lifetime as temperature decreases is probably due to the existence of states of lower oscillator strength lying just above the lowest excited level (Kisliuk *et al.*, 1968). However, the point for us here is the fact that the observed lifetime is nearly independent of temperature, as the difference between low temperature lifetime and room temperature lifetime is only about 1ms, suggesting that the contribution of non-radiative decay to the overall lifetime of the crystal may be insignificant. In other words, the transition from that energy level is predominantly radiative, and that may account for the strong 3.9 μm emission arising from that level in the halide crystal.

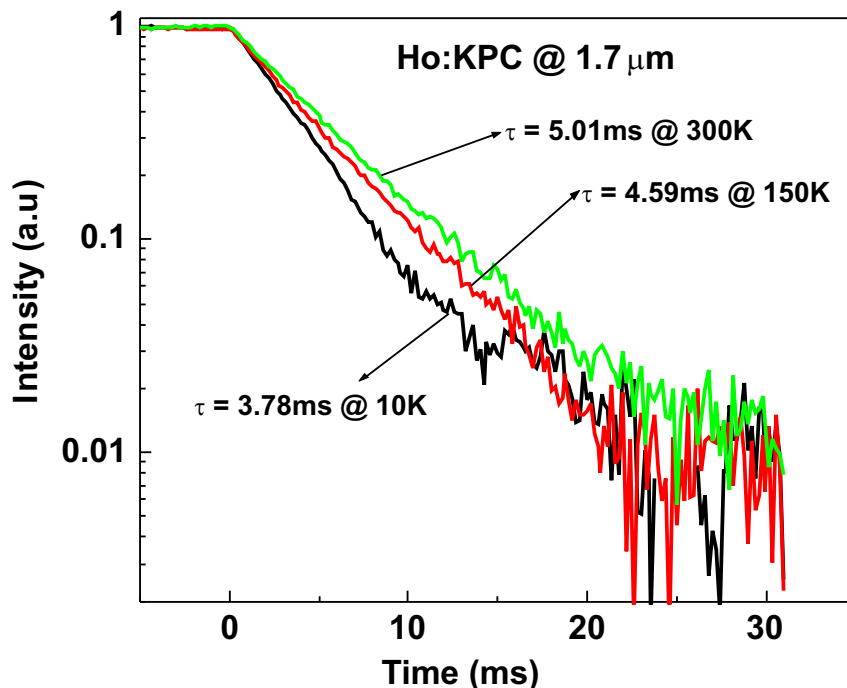

Figure 4. Temperature Dependent Decay Transients of <sup>5</sup>I<sub>5</sub> Emission in Ho<sup>3+</sup>:KPC @ 10K, 150K & 300K.

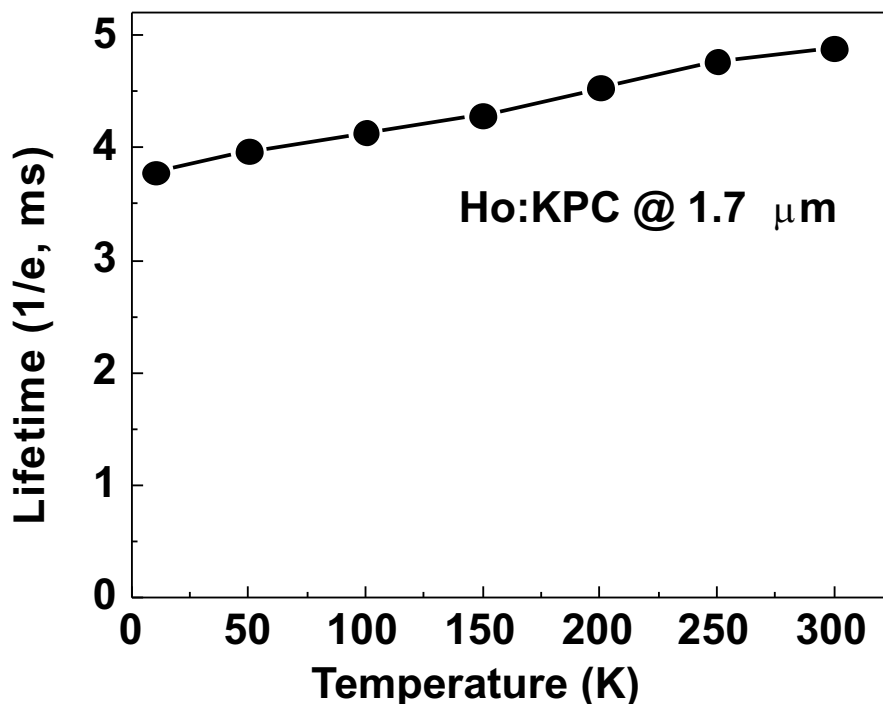

Figure 5. Emission Lifetime of The <sup>5</sup>I<sub>5</sub> level in Ho<sup>3+</sup>: KPC as a Function of Temperature.

## CONCLUSION

The emission properties of low phonon Ho<sup>3+</sup>:KPb<sub>2</sub>Cl<sub>5</sub> and high phonon Ho: CaF<sub>2</sub> were compared. While the 3.9 μm mid-IR emission was quenched in the CaF<sub>2</sub> host it was significantly observed in the KPb<sub>2</sub>Cl<sub>5</sub> host. This was attributed to the low phonon structure of the KPb<sub>2</sub>Cl<sub>5</sub> host matrix which allowed radiative transition from the <sup>5</sup>I<sub>5</sub> level as opposed to the CaF<sub>2</sub> host whose phonon structure could only allow multi-phonon relaxation from that level. Time resolved analysis of the Ho<sup>3+</sup>:KPb<sub>2</sub>Cl<sub>5</sub> further confirmed the dominance of radiative transition from that level. It may therefore be concluded that host matrices with low maximum phonon energies are suitable gain media for mid infrared diode-pumped lasers as observed in this work.

## ACKNOWLEDGMENT

The experimental part of this work was carried out at the Center for Laser Science and Spectroscopy (CLaSS) of Hampton University under the leadership of Prof. Uwe Hommerich. We acknowledge the funding support of the US Army Research Office and the NSF.

## REFERENCES

- Brown, E.; Hommerich, U.; Bluiett, A. G.; Trivedi, S. B. and Zavada, J. M. 2007. Synthesis and spectroscopic properties of neodymium doped lead chloride. *J. Appl. Phys.*, 101, 113103.
- Diening, A.; Dicks, B. M.; Heumann, E.; Meyn, J. P.; Petermann, K. and Huber, G. 1997. Continuous-Wave Lasing of Tm<sup>3+</sup> Doped Y<sub>2</sub>O<sub>3</sub> near 1.95 μm, *OSA TOPS Advanced Solid State Lasers*, Vol.10, 194-196.
- Duan, C. K.; Meijerink, A.; Reeves, R. J. and Reid, M. F. 2006. The unusual temperature dependence of the Eu<sup>2+</sup> fluorescence in CaF<sub>2</sub> crystals. *Journal of Alloys and Compounds*, 408-412, 784-787.
- Heo, J. 1997. 2.9 μm Emission and Multiphonon Relaxation in Ge<sub>25</sub>Ga<sub>5</sub>S<sub>70</sub> Glass doped with Dy<sup>3+</sup> and Tm<sup>3+</sup>, *OSA TOPS Advanced Solid State Lasers*, Vol.10, 226-231.
- Isaenko, L.; Yelisseyev, A.; Tkachuk, A.; Ivanova, S.; Vatnik, S.; Merkulov, A.; Payne, S.; Page, R. and Nostrnad, M. 2001. New laser crystals based on KPb<sub>2</sub>Cl<sub>5</sub> for IR region. *Material Science and Engineering*, B81, 188-190.
- Isaenko, L.; Yelisseyev, A.; Tkachuk, A.; Ivanova,



- S.; Payne, S.; Page, R. and Nostrand, M. 2002. New low-phonon frequency crystals, based on rare earth doped double halogenides for multiwavelengths diode pumped solid-state lasers, KPb<sub>2</sub>Cl<sub>5</sub> for IR region. *SPIE Proceedings*, Vol.4900.
- Joullie, A.; Christol, P.; Baranov, A. N. and Vicet, A. 2003. Mid-Infrared 2-5 μm Heterojunction Laser Diodes. *Solid-State Mid-Infrared Laser Sources, Topics Appl. Phys.* 89, 1-59.
- Kalisky, Y. 1999. New trends in lasers and laser crystals. *Optical Materials*, 13, 135-139.
- Kaminskii, A. A. 1996. Crystalline Lasers: Physical Processes and Operating Schemes, *CRC Press*.
- Kisliuk, P.; Tippins, H. H. and Moore, C. A. 1968. Optical Spectrum and Zeeman Effect of CaF<sub>2</sub>:Eu<sup>2+</sup>. *Phys. Rev.*, 171, 2, 336-342.
- Nostrand, M. C.; Page, R. H.; Payne, S. A.; Isaenko, L. I. and Yelisseyev, A.P. 2001. Optical properties of Dy<sup>3+</sup>- and Nd<sup>3+</sup>-doped KPb<sub>2</sub>Cl<sub>5</sub>. *J. Opt. Soc. Am. B*, 18, 3.
- Orlovskii, Y.V.; Basiev, T.T.; Vorob'ev, I.N.; Orlovskaya, E. O.; Barnes, N. P. and Mirov, S.B. 2002. Temperature dependencies of excited states lifetimes and relaxation rates of 3-5 phonon (4-6 μm) transitions in the YAG, LuAG and YLF crystals doped with trivalent holmium, thulium, and erbium. *Optical Materials*, 18, 355-365.
- Oyebola, O.; Hommerich, U.; Brown, E.; Trivedi, S. B.; Bluiett, A. G. and Zavada, J. M. 2010. Growth and Optical Spectroscopy of Ho doped KPb<sub>2</sub>Cl<sub>5</sub> for Infrared Solid-State Lasers. *Journal of Crystal Growth*, Volume 312, Issue 8, Pages 1154-1156.
- Pujol, M. C.; Massons, J.; Aguilo, M.; Diaz, F.; Rico, M. and Zaldo, C. 2002. Emission cross sections and spectroscopy of Ho<sup>3+</sup> laser channels in KGd(WO<sub>4</sub>)<sub>2</sub> single crystal. *IEEE Journal of Selected Topics in Quantum Electronics*, Vol.38, No.1, 93-100.
- Rademaker, K.; Heumann, E.; Payne, S. A.; Huber, G.; Krupke, W. F.; Isaenko, L. I. and Burger, A. 2005. Laser activity at 1.18, 1.07, and 0.97 μm in the low-phonon-energy hosts KPb<sub>2</sub>Br<sub>5</sub> and RbPb<sub>2</sub>Br<sub>5</sub> doped with Nd<sup>3+</sup>. *Opt. Lett.*, 30, 729.
- Schneider, J.; Carbonnier, C. and Unrau, U. B. 1997. Characterization of a Ho<sup>3+</sup>-doped fluoride fiber laser with a 3.9-μm emission wavelength. *Applied Optics*, Vol.36, No.33, pp. 8595-8600.
- Tittel, F.K.; Richter, D. and Fried, A. 2003. Mid-Infrared Laser Applications in Spectroscopy, *Solid-State Mid-Infrared Laser Sources, Topics Appl. Phys.* 89, 445-510.