

On the relationship between stress intensity factor (K) and minimum plastic zone radius (MPZR) for four point bend specimen under mixed mode loading

S. K. Kudari^{1*}, C. M. Sharanaprabhu²

^{1*} Principal, Sanjeevan Engineering & Technology Institute, Panhala-416201, Maharashtra INDIA

² Department of Mechanical Engineering, Bapuji Institute of Engineering & Technology, Davanagere, Karnataka, INDIA

*Corresponding Author: e-mail: s.kudari@rediffmail.com, Tel +91-2328-235489, Fax. +91-2328-235490

Abstract

Studies on crack-tip plastic zones are of fundamental importance in describing the process of failure and in formulating various fracture criteria. Minimum plastic zone radius (MPZR) theory is widely used in prediction of crack initiation angle in mixed mode fracture analysis of engineering materials. In this study, shape and size of mixed mode (I/II) crack-tip plastic zones have been estimated by finite element analysis in a four point bend specimen according to von Mises yield criteria. The results obtained are used to analyze the MPZR criterion with respect to the effective stress intensity factor (K_{eff}) and elastic mode mixity (M_e).

Keywords: minimum plastic zone radius, mixed mode I/II, finite element analysis, mode mixity, four point bend specimen.

1. Introduction

In many engineering problems cracks are not normal to the maximum principal stress direction, and a mixed-mode (combined modes I and II) condition prevails at the tip of such cracks. Hence, analysis of mixed mode crack problems is important in structural integrity assessments. Prediction of crack initiation and orientation with its propagation path under mixed-mode loading is desirable for life prediction of engineering materials (Nobile, 2000, Sansino, 2001, Pitoiset and Rychlk, 2001). The stress amplitude at the crack tip subjected to a loading provokes a region of plastic deformation in a localized zone at the crack tip, referred to as the *plastic zone*. This zone also contains damage that leads to either a total or progressive fracture depending on the properties of the material. The growth of the crack is linked to the existence of this plastic zone at the crack tip, whose formation and development are accompanied by energy dissipation. In mixed mode fracture, the studies of the crack-tip plastic zones are of fundamental importance in describing the process of failure and in formulating various fracture criteria. Shih (1973) showed that the amplitude of asymptotic stress field near the crack tip for mixed mode loading under small scale yielding (SSY) is parameterized by the elastic mode mixity parameter $M_e = 2/\pi \tan^{-1}(K_I/K_{II})$, where K_I and K_{II} are the mode I and II stress intensity factors. Shahani and Tabatabaei (2009) used a non dimensional parameter, $\beta_{eq} = \tan^{-1}(K_I/K_{II})$ for four point bend specimen, where β_{eq} is the loading equivalent angle. Consequently, elastic mode mixity depends upon the loading equivalent angle. In mixed mode fracture, it is known that the crack initiation angle depends on the loading angle (Bian and Kim, 2004), which in turn depends upon elastic mode mixity. It is also known that the mode mixity alters the shape and size of the crack-tip plastic zone. Several investigators (Bian and Kim, 2004; Golos and Wasiluk, 2000; Wasiluk and Golos, 2000; Khan and Khraisheh, 2004) have proposed fracture criteria for the prediction of the crack-initiation angle based on the analytical estimates of crack-tip plastic zone size in mixed mode fracture. The analytical estimates were obtained by Linear Elastic Fracture Mechanics (LEFM) approach. Recently, Bian and Kim (2004), and Khan and Khraisheh (2004), have proposed a minimum plastic zone radius (MPZR) theory for crack initiation angle in mixed mode and monotonic loading. MPZR theory states that the crack is initiated in the direction where the radius of plastic zone takes either a local or global minimum depending on the loading direction. This kind of study needs detailed information about the crack-tip plastic zone shape and size in a fracture specimen estimated by numerical method

such as the finite element method. Benrahou *et al.* (2007) have estimated the plastic zone under mixed mode loading by the finite element method, but the details of the mixed mode plastic zone analysis are missing in their investigation. Four point bend specimen is one of the most important specimen of the fracture mechanics because it can produce mixed Modes I and II. Thus, in the present investigation an effort is made to: (a) study the size and shape of mixed mode plastic zone in a four point bend specimen using FEM and (b) analyze the MPZR with respect to the effective stress intensity factor (K_{eff}) and elastic mode mixity (M_e).

2. Finite element analysis

A series of 2D stress analyses by finite element method have been made on Four Point Bend specimen using ABAQUS 6.5 (2001), finite element software. The dimensions of the specimen, loading and displacement boundary conditions used in this analysis are similar to the one used in the earlier work (Shahani and Tabatabaei, 2009). The geometry of the specimen considered in this analysis is shown in Fig.1. Finite element computations were carried out considering full specimen geometry due to the antisymmetry loading. The analysis domain is discretized using 8-noded isoparametric 2D solid elements. This kind of elements is used in the work of Pironi and Dalle (2001), for computation of K . The analytical formulations of K_I and K_{II} (He and Hutchinson, 2000) are as follows:

$$K_I = \frac{6Qs}{W^2} \sqrt{\pi a} F_I \left(\frac{a}{W} \right) \tag{1}$$

$$K_{II} = \frac{Q(a/W)^{3/2}}{W^{1/2}(1-a/W)^{1/2}} F_{II} \left(\frac{a}{W} \right) \tag{2}$$

where, $Q = \frac{F(L-d)}{L}$

The functions F_I and F_{II} were defined by Murakami (1987), as polynomial functions:

$$F_I \left(\frac{a}{W} \right) = 1.122 + 1.12(a/W) + 3.740(a/W)^2 + 3.873(a/W)^3 - 19.05(a/W)^4 + 22.5(a/W)^5 \text{ for } 0 \leq a/W \leq 0.7$$

$$F_{II} \left(\frac{a}{W} \right) = 7.264 - 9.37(a/W) + 2.74(a/W)^2 + 1.87(a/W)^3 - 1.04(a/W)^4 \text{ for } 0 \leq a/W \leq 1$$

The method of extraction of K used in this Finite Element analysis is in similar manner as explained in the work of Kodancha and Kudari (2008) carried out by maximum tangential stress criterion as available in ABAQUS. A typical Two-dimensional FE mesh used in the study is shown in Fig. 2. The specimen is analyzed for 9 different crack positions and for same applied loading position (*i.e.* $d/W=1.6$ constant for all the specimens). These 9 cases corresponds to the different crack distances from the middle of the specimen by varying the s/W ratios from 0 to 1.6 by an increment of 0.2, therefore an average number of elements used in the FE analysis is 2500–3000. In these calculations, the material behavior has been considered to be linear elastic type pertaining to interstitial free steel (IF) possessing the yield strength (σ_y) of 155 MPa, Poisson’s ratio (ν) of 0.3 and elastic modulus (E) of 197 GPa (Kodancha and. Kudari, 2008).

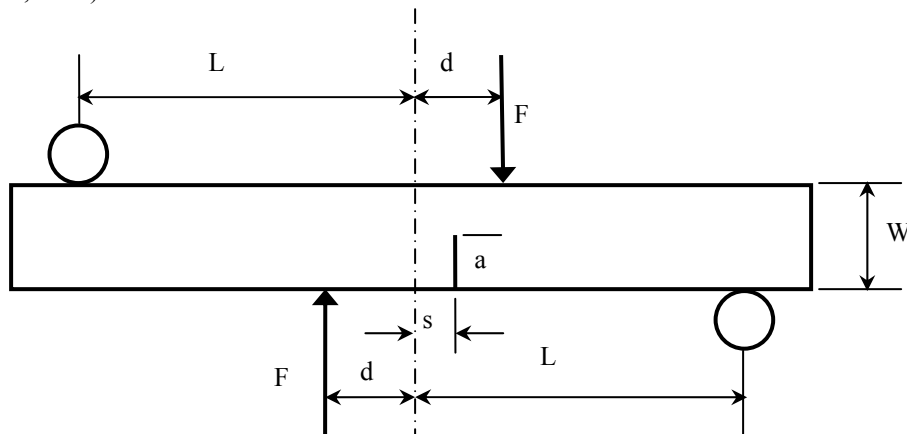

Figure.1. Specimen configuration used in the analyses $W=30\text{mm}$, $L=86\text{mm}$, $B = 3 \text{ mm}$.

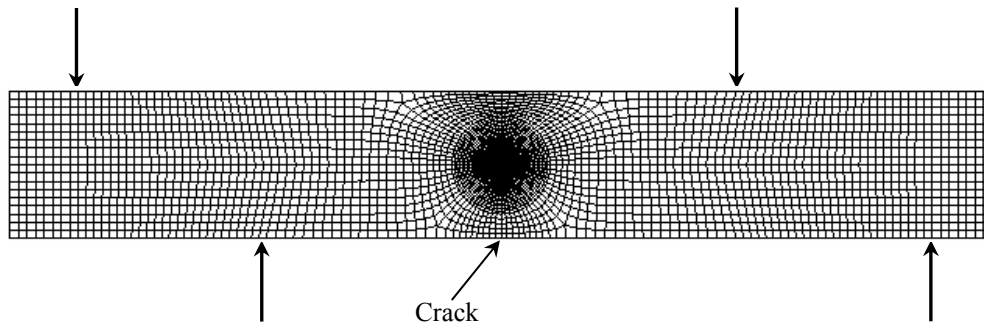

Figure 2. FE mesh used in the analyses.

3. Results and Discussions

Different load steps were applied for various s/W ratios of the specimen to estimate the stress intensity factor (K) and to study the plastic zone shape and size ahead of the crack-tip. The stress intensity factors in mixed mode loading (K_I and K_{II}) were computed for various load steps and different s/W ratios using the ABAQUS post processor. The failure locus under mixed mode loading *i.e* variation of K_{II} vs. K_I for various loading is depicted in Fig. 3. This figure indicates that for the similar applied load, the stress intensity factor in mode-I is more than that of mode-II. This nature of variation of K_{II} vs. K_I is in good agreement with the results shown by Sharanaprabhu and Kudari (2008), on a Compact tensile shear (CTS) specimen under mixed mode loading. The magnitudes of K_I and K_{II} have also been computed by analytical formulations given in Equations (1) and (2) (He and Hutchinson, 2000). The estimated theoretical values of stress intensity factors have been superimposed in Fig.3 typically for load 1kN and 6 kN by dotted lines. This figure clearly indicates that there exists some discrepancy in the estimation of stress intensity factors by analytical formulation (He and Hutchinson, 2000) and present FE results. It is found that there is 7.5% and 2.4% error in estimation of K_I and K_{II} respectively. This discrepancy in estimated magnitudes of stress intensity factor attributed to varied s/W ratio and bend loading condition in FE analysis, which is not considered in analytical formulation. The effective stress intensity factors (K_{eff}) in mixed mode loading have been computed using the relation (Benrahou *et al.*, 2007):

$$K_{eff} = \sqrt{K_I^2 + K_{II}^2} \tag{3}$$

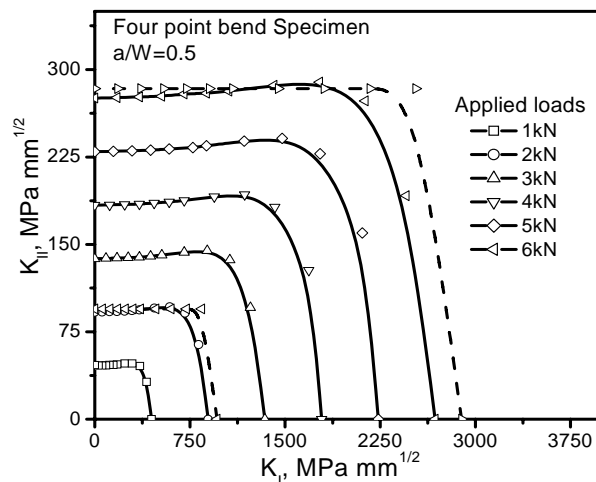

Figure 3. Variation of K_{II} vs. K_I for different applied loads.

The computed magnitudes of K_{eff} are plotted against various s/W ratios for various applied loads in Fig.4. This figure indicates that for a particular load the magnitude of K_{eff} increases as s/W increases. It is also clear from Fig.4 that, for a particular applied load, K_{eff} in mode-I ($s/W=1.6$) is more than that of mode-II ($s/W=0$). The nature of variation of K_{eff} vs. s/W (Fig.4) is in similar manner with the earlier reported results (Benrahou *et al.*, 2007, Sharanaprabhu and Kudari, 2008)

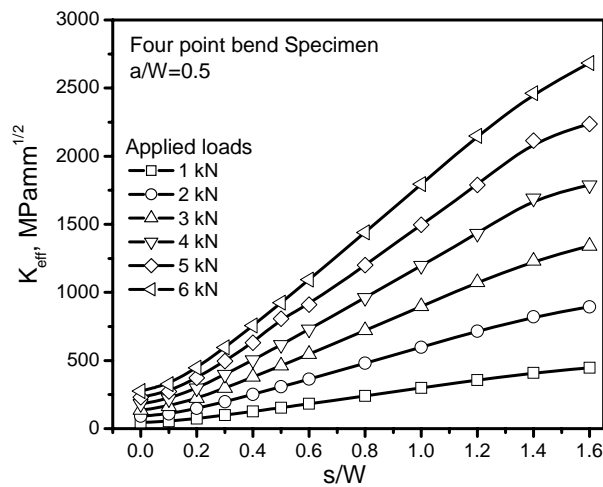

Figure 4. Variation of K_{eff} vs. s/W for different applied loads.

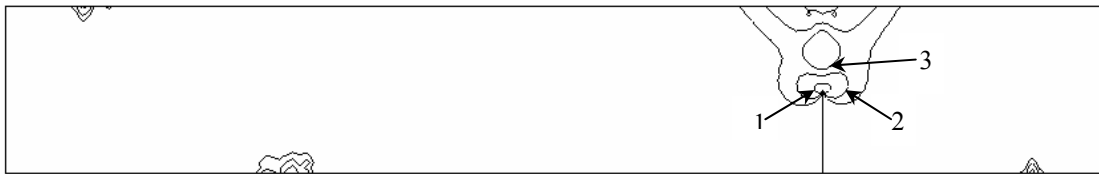

Figure 5. Sequential development of plastic zone for $s/W=1.6$. Number 1, 2, 3 indicates the plastic zone for applied load 1, 2 and 3kN.

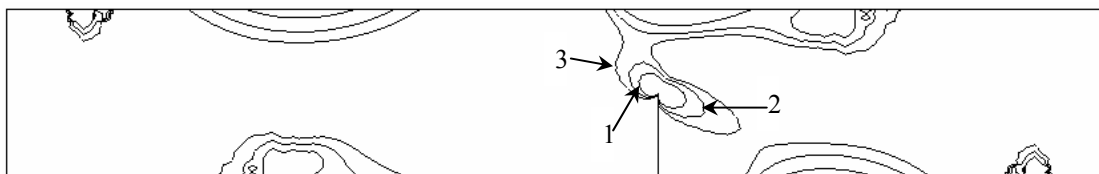

Figure 6. Sequential development of plastic zone for $s/W=0.8$. Number 1, 2, 3 indicates the plastic zone for applied load 4,5 and 6kN.

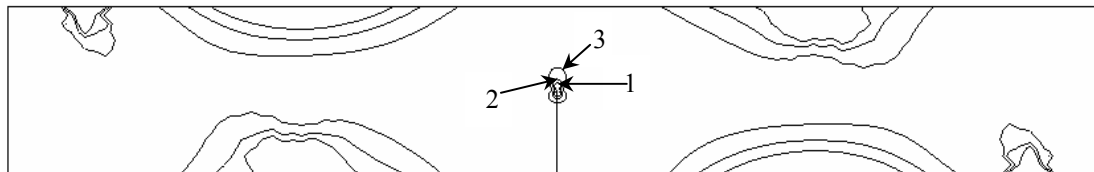

Figure 7. Sequential development of plastic zone for $s/W=0$. Number 1, 2, 3 indicates the plastic zone for applied load 5, 6 and 8kN.

The shape of the nominal plastic zone ahead of a crack-tip has been ascertained by plotting iso-contours of the effective stress, which causes yielding according to von Mises yield criterion (Gdoutos and Papakalitikis, 1987). Since, in this study elastic constitutive model is used for the material, contour plotting of the von Mises stress corresponds to the nominal plastic zone shape. This is different from the actual plastic zone that is affected by stress redistribution during plastic flow. However, for the purposes of the present study the consideration is focused on the nominal plastic zone, due to the considerably greater ease of analysis. The sequential development of crack-tip plastic zone for various applied loads and for $s/W=0$ (Mode-II), $s/W=0.8$ (Mixed mode-I and II) and $s/W=1.6$ (Mode-I) are shown in Fig. 5, Fig. 6 and Fig. 7. The contours in Fig. 5, Fig. 6 and Fig. 7 are obtained by superimposing the plastic zone contour obtained in each load step. For simplicity the displacement scaling of the specimens shown

in Fig. 5, Fig. 6 and Fig. 7 are set to zero. Fig. 5 demonstrates that the plastic zone grows in horizontal direction (perpendicular to the ligament) for $s/W=1.6$, as s/W ratio is changed (mixed mode) the angle of stretch (θ to crack plane) of plastic zone also changes are shown in Fig.6, and for $s/W=0$ the plastic zone grows vertically (along the ligament) are shown in Fig. 7. The nature of the plastic zones obtained in this analysis is in good agreement with the theoretical plastic zone shapes presented in (Benrahou *et al*, 2007, Sharanaprabhu and Kudari, 2008). It is also seen from Fig. 5, Fig. 6 and Fig. 7 that for similar applied load the extent of plastic zone ahead of crack-tip for $s/W=0$ is higher compared to one for $s/W=0.8$ and 1.6. It is well known that the fracture toughness of the material is governed by the size of plastic zone ahead of the crack-tip (Kudari *et al.*, 2007). The size of plastic zone for $s/W=1.6$ (Mode-I) is minimum as compared to $s/W < 1.6$. Therefore, these results clearly demonstrate why Mode-I loading is more dangerous than mixed mode or Mode-II loading.

To illustrate the development of the crack-tip plastic zones for various s/W ratios ($s/W=0$ to 1.6) and applied load 2kN, the contours are superimposed and shown in Fig. 8. From this figure one can find that for similar applied load at various s/W ratios, the direction of growth of the plastic zone under goes rotation. It is also interesting to note that the shape of the plastic zone at various s/W remains almost similar, with some change in the size and orientation. From the results for plastic enclaves shown in Fig. 5, Fig. 6, Fig. 7 and Fig. 8, several plastic-zone characterizing parameters can be estimated at various load steps and s/W ratios such as: (i) plastic zone size along the crack plane, r_p , (ii) maximum plastic zone size, $(r_p)_{max}$, (iii) angle at which the maximum extent of plastic zone occurs, θ , measured from the crack plane, (iv) minimum plastic zone radius (MPZR) and (v) angle at which MPZR occurs, θ_o . These parameters are schematically illustrated in Fig. 9.

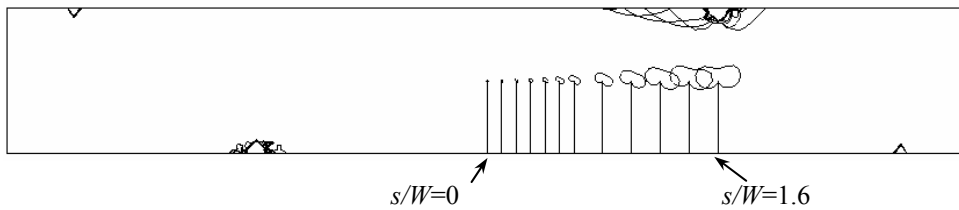

Figure 8. Typical plastic zone contours for $s/W=0-1.6$ and $a/W=0.5$ for applied load 2 kN.

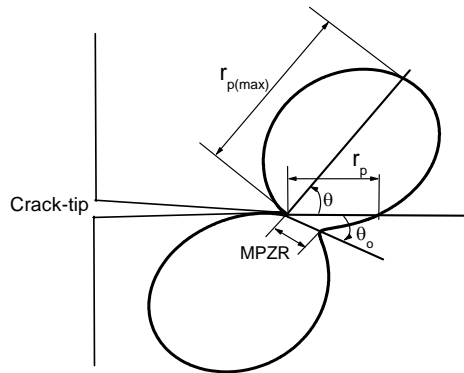

Figure 9. Schematic representation of plastic zone characterizing parameters.

The variation of the plastic zone characterizing parameters r_p and $(r_p)_{max}$ vs. K_{eff} , and θ vs. s/W for four point bend specimen are shown in Fig. 10, Fig. 11 and Fig. 12 respectively. Fig. 10 shows the variation of r_p vs. K_{eff} for various s/W ratios. This figure illustrates that the plastic zone size ahead of the crack-tip increases with K_{eff} . It is also clear from Fig. 10 that, for a particular magnitude of K_{eff} (for example, $300 \text{ MPa mm}^{1/2}$) the value of r_p is least for $s/W=1.6$ (mode-I) and it is highest for $s/W=0$ (Mode-II). The difference in magnitudes of r_p for $s/W=0$ and 1.6 for $K_{eff} = 300 \text{ MPa mm}^{1/2}$ is about 4 mm, which is 6.291 times that of Mode-I. These results infer that, due to minimum plastic zone radius ahead of crack-tip for a particular value of K_{eff} , mode-I loading can lead to material fracture earlier than any mixed mode or mode-II loading.

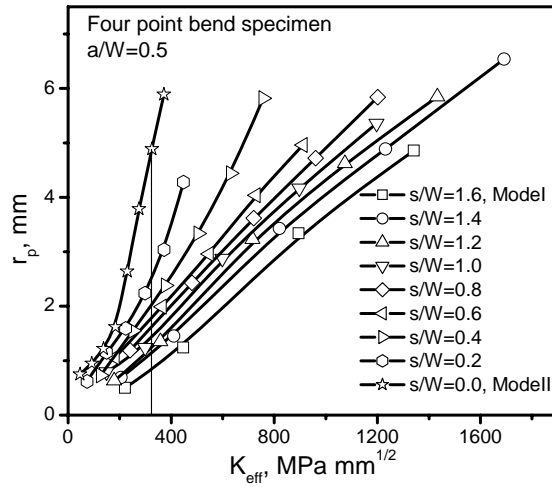

Figure 10. Variation of r_p vs. K_{eff} for various s/W

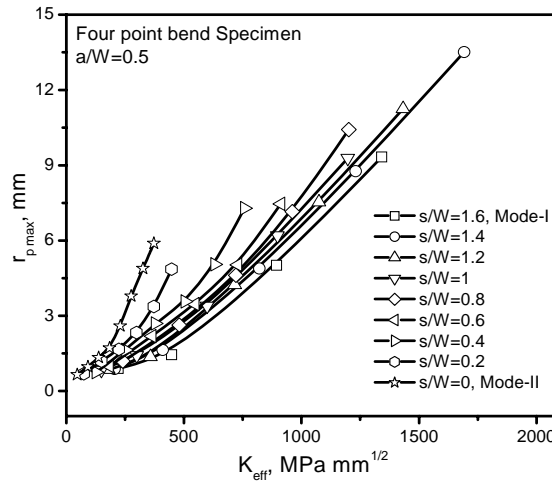

Figure 11. Variation of $(r_p)_{max}$ vs. K_{eff} for various s/W

The variation of $(r_p)_{max}$ vs. K_{eff} for various s/W ratios is depicted in Fig. 11. This figure also indicates that the magnitude of $(r_p)_{max}$ for a particular value of K_{eff} is least for $s/W=1.6$ (mode-I) and it is highest for $s/W=0$ (mode-II). These results (r_p and $(r_p)_{max}$) indicate clearly that the area of plastic zone in mode-I is much smaller than that of mode-II for the similar magnitude of K_{eff} . This analysis infers that for the similar magnitude of K_{eff} the energy absorption capacity of the material in Mode-I is much lower than under Mode-II loading. One can conclude from this analysis that, due to smaller plastic area ahead of the crack-tip, the mode-I loading leads to early fracture, hence in fracture, Mode-I loading is considered to be more dangerous than mode-II. The plot of the angle at which the maximum extent of plastic zone occurs, θ , vs. s/W , is shown in Fig. 12. This plot indicates that the angle at which the maximum extent of plastic zone size occurs (θ) changes from 0° to 90° as s/W is varied from 0 to 1.6. This figure indicates that the variation of θ vs. s/W is perfectly independent of applied loads.

The variation of minimum plastic zone radius (MPZR) vs. s/W for various applied loads is depicted in Fig. 13. This figure indicates that the magnitude of MPZR increases as the s/W ratio is changed from 0 (Mode-II) to 1.6 (Mode-I). It is interesting to note that the magnitude of MPZR in Mode-II loading is about almost 4.25 times less than that of Mode-I for applied load 1kN. It is observed from Fig.13 that the ratio of MPZR between Mode-I and Mode-II increases with the increase in the applied load. In the case of applied load of 3 kN, this ratio is found to be almost 6.5. These results clearly demonstrate that the specimen experiences minimum plastic zone radius under Mode-II loading only. The results of MPZR estimated using FEM in this study can be used as inputs for minimum plastic zone radius (MPZR) criterion for estimating crack initiation angle (Bian and Kim, 2004; Khan and Khraisheh, 2004) in mixed mode loading for a four point bend specimen.

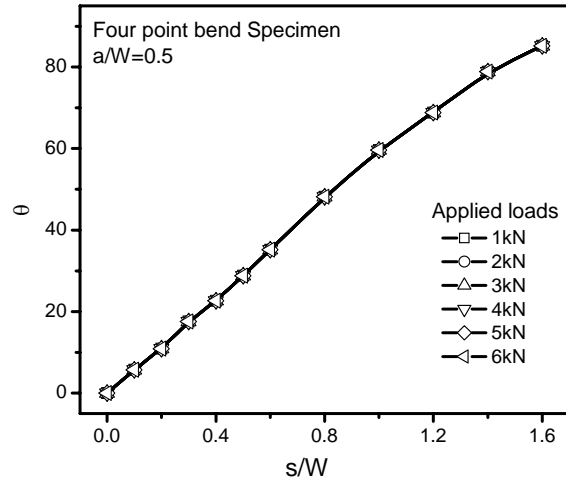

Figure 12. Variation of θ vs. s/W for various loads

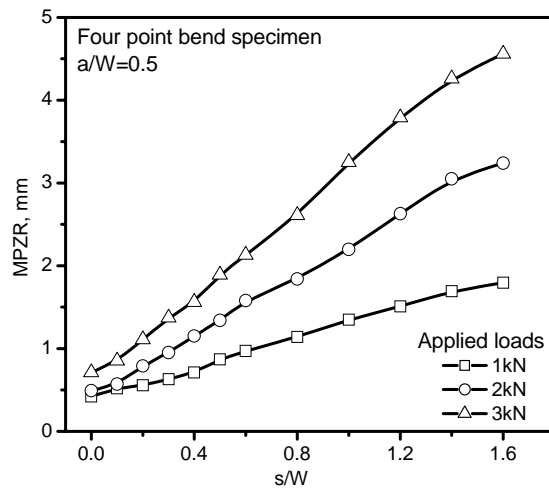

Figure 13. Variation of MPZR vs. s/W for various loads

The variation of the minimum plastic zone radius (MPZR) vs. effective stress intensity factor (K_{eff}) is also studied; the plot of MPZR vs. K_{eff} for various s/W ratios is depicted in Fig. 14. It is interesting to note from this figure that the variation of MPZR vs. K_{eff} is linear and the slopes of this variation for different magnitudes of s/W ratio appear to be independent of s/W ratios. This figure infers that for any loading angle the growth of MPZR is proportional to the effective stress intensity factor. The proportionality constant can be evaluated by fitting a straight line equation to all the MPZR data. Such a linear fit is shown in Fig.14; the slope of the estimated linear fit line is 0.0035. From these results, the relation between MPZR and K_{eff} independent of s/W ratio can be expressed as:

$$\frac{MPZR}{K_{eff}} = 0.0035 \tag{4}$$

The Equation (4) can be used to estimate MPZR in a Four point bend specimen independent of the s/W ratio if K_{eff} is known, or vice versa. The proposed Equation (4) can be of great use in mixed mode fracture analysis using MPZR criteria.

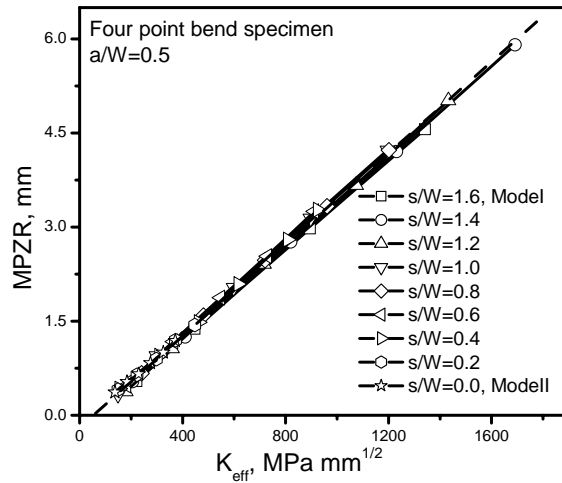

Figure 14. Variation of MPZR vs. K_{eff} for various s/W

In this study the angle at which MPZR occurs (θ_0) is also studied with respect to the elastic mode mixity (M_e). The variation of θ_0 vs. elastic mode mixity obtained in this analysis for various applied loads is compared with the results of Bian and Kim (2004), and Khan and Khraisheh (2004), by converting loading angle into elastic mode mixity parameter is depicted in Fig. 15. This figure shows that the magnitude of θ_0 decreases from 90° to 0° as M_e changes from 0 to 1. The results shown in Fig. 15 indicate that the magnitude of θ_0 computed for various applied loads and a particular M_e is almost similar. A small dissimilarity observed in estimated θ_0 for various M_e can possibly be attributed to measurement difficulties in FE post processor. Bian and Kim, 2004, and Khan and Khraisheh, 2004, have considered that the crack in mixed mode loading initiates in the direction of MPZR from MPZR theory. These investigators have used the magnitude of θ_0 for defining the crack initiation angle. The nature of the variation of θ_0 vs. M_e obtained in the present analysis shown in Fig. 15. The variation of θ_0 vs. M_e are similar to the results of Khan and Khraisheh (2004), and slightly differs from the results of Bian and Kim (2004), as the results in Bian and Kim (2004) are obtained for plane strain analysis. Figure 15 shows that for a specimen under Mode-I ($M_e=1$) loading crack initiation angle is 0° indicating that the crack initiates along the ligament. And for a specimen under mode-II ($M_e=0$) loading crack initiation angle is 90° , and the crack initiates almost perpendicular to the ligament. For mixed mode loading (M_e between 0 and 1) the crack initiation angle is found to be between $0-90^\circ$. It is interesting to know from this graph that the variation of θ_0 vs. M_e is independent of applied load. The results presented in this study are useful to researchers and industrial scientists to predict the magnitude of MPZR and θ_0 (crack initiation angle) by only knowing the magnitude of K_I and K_{II} which can be quickly obtained by analytical formulations.

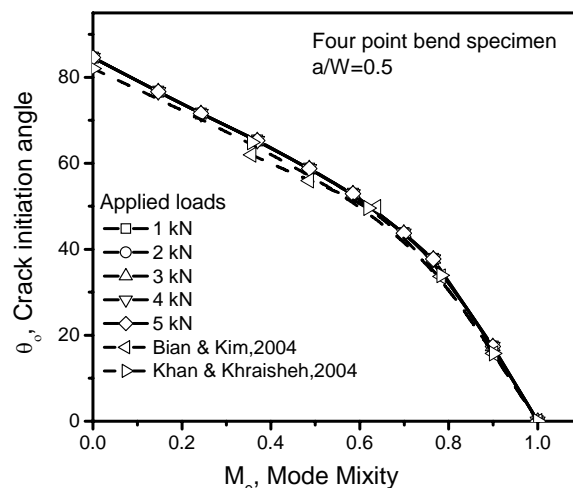

Figure 15. Variation of θ_0 vs. M_e for various loads

4. Conclusions

The following conclusions are drawn from the present study:

- The magnitude of the nominal plastic zone size ahead of the crack-tip (r_p) for a particular value of K_{eff} is least for $s/W=1.6$ (mode-I) and it is highest for $s/W=0$ (mode-II)
- The angle at which the maximum extent of plastic zone size occurs (θ) changes from 0° to 90° as s/W is varied from 0 to 1.6
- Minimum plastic zone radius (MPZR) and the angle at which MPZR occurs, θ_o , depends on the s/W ratios.
- The variation of MPZR with K_{eff} is linear and is independent of the s/W (load mixity), and
- A relation between MPZR and K_{eff} is proposed, which can be useful in application of the MPZR criterion for mixed mode fracture problems.

Acknowledgment

Authors gratefully acknowledge the computational facilities provided by the Research Centre, B V B College of Engineering & Technology, Hubli-580 031, India.

References

- Bian L., C., Kim K., S., 2004. The minimum plastic zone radius criterion for crack initiation direction applied to surface cracks and through-cracks under mixed mode loading. *International Journal of Fatigue*, Vol.26, pp.1169-1178.
- Benrahou K., H., Benguediab M., Belhoury M., Nait-Abdelaziz, Imad A., 2007. Estimation of plastic zone by finite element method under mixed mode (I and II) loading. *Computational Materials Science*, Vol.38, pp.595-601.
- Gdoutos E., Papakalitakis G., 1987. Crack growth initiation in elastic-plastic materials. *International Journal of Fracture*, Vol.32, pp.143-156.
- Golos K., Wasiluk B., 2000. Role of plastic zone in crack growth direction criterion under mixed mode loading. *International Journal of Fracture*, Vol.102, pp.341-353.
- Hibbitt, Karlsson, Sorensen Inc., ABAQUS Users Manual, Version 6.5.
- He M., Y., Hutchinson J., W., 2000. Asymmetric four-point crack specimen. *Journal of Applied Mechanics*, Vol. 67, pp.207-209.
- Kahan S., M., A., Khraisheh M., K., 2004. A new criterion for mixed mode fracture initiation based on crack-tip plastic core region. *International Journal of Plasticity*, Vol.20, pp.55-84.
- Kudari S., K., Maiti B., Ray K., K., 2007. The effect of specimen geometry on plastic zone size: a study using the J integral. *Journal of Strain Analysis*, Vol. 42, pp.125-136.
- Kodancha K., G., Kudari S., K., 2009. Variation of stress intensity factor and elastic T-stress along the crack-front in finite thickness plates. *Frattura ed Integrità Strutturale*, Vol.8, pp.45-51.
- Murakami Y., 1987. Stress Intensity Factors Hand Book. Pergamon Press, New York.
- Nobile L., 2000. Mixed mode crack initiation and direction in beams with edge crack. *Theoretical and Applied Fracture Mechanics*, Vol.33, pp.107-116.
- Pitoiset X., Rychlik I., Preumont A., 2001. Spectral methods to estimate local multiaxial fatigue failure for structures undergoing random vibrations. *Fatigue and Fracture of Engineering Materials and Structures*, Vol.24, pp. 715-727.
- Pirondi A., Dalle Donne C., 2001. Characterization of ductile mixed-mode fracture with the crack-tip displacement vector. *Engineering Fracture Mechanics*, Vol.68, pp.1385-1402.
- Shih C.F., 1973. Elastic-plastic analysis of combined mode crack problems. PhD Thesis, Harvard University. Cambridge, Massachusetts, USA.
- Sonsino C. M., 2001. Influence of load and deformation-controlled multiaxial tests on fatigue life to crack initiation. *International Journal of Fatigue*, Vol. 23, pp.159-167.
- Sharanaprabhu C., M., Kudari S., K., 2008. Finite element analysis of minimum plastic zone radius criterion for crack initiation direction under mixed mode loading. *American institute of physics conference proceedings*. Vol. 1138, pp.13-22.
- Shahani A.R., Tabatabaei S.A., 2009. Effect of T-stress on the fracture of a four point bend specimen. *Materials and Design*, Vol.30, pp.2630-2635.
- Wasiluk B., Golos K., 2000. Prediction of crack growth direction under plane stress for mixed mode I and II loading. *Fatigue and Fracture of Engineering Materials and Structures*, Vol.23, pp.381-386.

Biographical notes

Dr. S. K. Kudari received M. Tech. and Ph.D. from Indian Institute of Technology, Kharagpur, India in 1995 and 2004, respectively. He has more than 20 years of experience in teaching and research. He is the Principal of Sanjeevan Engineering & Technology Institute, Panhala, Maharashtra. Formerly, Professor in the Department of Mechanical Engineering, B.V.B College of Engg. & Tech., Hubli, India. His research interests include Stress analysis, Fracture Mechanics. He is a Member of IE (India), ISTE (India), ISME, IAENG, ESIS, ISTAM. He has delivered several guest lectures in reputed institutes in his research areas.

C. M. Sharanaprabhu is a Lecturer in the Department of Mechanical Engineering, Bapuji Institute of Engineering & Technology, Davangere, India. He is pursuing Ph.D at Research Centre, Department of Mechanical Engineering, B V B College of Engineering & Technology, Hubli, affiliated to Visveshwaraya Technological University, Karnataka, India.

Received April 2010

Accepted May 2010

Final acceptance in revised form May 2010