

# Performance of solar photovoltaic array fed water pumping system utilizing switched reluctance motor

Bhim Singh<sup>1\*</sup>, Anjaneer Kumar Mishra<sup>2</sup>

<sup>1\*</sup>Department of Electrical Engineering, Indian Institute of Technology Delhi, INDIA

<sup>2</sup>Department of Electrical Engineering, Indian Institute of Technology Delhi, INDIA

\*Corresponding Author: e-mail: bsingh@ee.iitd.ac.in , Telephone: +91 11 26591890.

## Abstract

This paper discusses the design and performance analysis of a solar photovoltaic (SPV) array fed water pumping system utilizing a special class of highly rugged machine with simple drive system called switched reluctance motor (SRM) drive. The proposed method of water pumping system also provides the cost effective and highly reliable solution for solar water pumping system. A unique approach of variable DC link voltage operation of SRM drive with electronic commutation for switches of mid-point converter is used with the elimination of voltage and current sensor in the motor side results in reduction in cost and losses of the system. A DC-DC single-ended primary-inductor converter (SEPIC) is used to achieve maximum power from SPV array. The characteristic of providing output voltage with no polarity reversal and having features like minimal active components and low noise operation makes SEPIC suitable for solar water pumping. The water pump with a SRM motor is used in the proposed system because of its similar operational characteristics compared to SPV generator.

*Keywords:* SPV Array, MPPT, SEPIC converter, Soft starting, SRM, Centrifugal water pump.

DOI: <http://dx.doi.org/10.4314/ijest.v7i3.1S>

## 1. Introduction

Environmental pollution, rapid depletion and increasing cost of fossil fuels are nowadays the major concerns. An urgent need of the hour is to have an alternative energy source which tackles these problems. The solar energy is one of the promising alternatives to the fossil fuel based energy sources. Though the solar power is free of cost, the main obstacle is initial establishment cost which is very high compared to other sources of energy. As the cost of solar photovoltaic (SPV) array is reducing day by day making a way SPV power generation cheaper and feasible. The recent advancements in photovoltaic modules and power electronics technologies make solar power a quite attractive solution for standalone power generation and applications like water pumping. SPV array fed water pumping system is fitted with manual or with auto-trackers for synchronizing with the shifting direction of the sun. In this way, solar panel captures sun rays continuously and keeps generating energy.

In this paper, a Matlab/Simulink model of SPV array (Kishor, Mohanty, Villalva and Ruppert, 2010) fed water pumping system using SRM drive (Krishnan, 2001) is developed to demonstrate the effect of temperature and insolation variations on the behavior of proposed system. Due to the suitability for system and excellent behavior as a step- up/step-down converter (Singh and Singh, 2010), SEPIC is used as an intermediate power electronic interface between PV panel and SRM drive. The maximum power control of PV panel using perturb and observe (P&O) method of MPPT involves iterative approach that perturbs the MPP point of SPV system to find desired direction for maximizing the power (Sharma and Purohit, 2012; Sullivan and Powers, 1993). The P&O method is not suitable for rapid change in environmental conditions but this problem can be overcome by comparing the incremental panel conductance with instantaneous panel conductance (Hussein, Muta, Hoshino and Osakada, 1995). SPV based water pumping system with variable speed drive is most efficient and reliable approach of water pumping due to smooth and fast dynamic power supply to the load (Johnson, 2004).

The windings of SRM are excited with the pulse voltage supply rather than a sinusoidal supply which makes the easy excitation system for SRM with low switching losses. The SRM has high starting torque and wide speed range characteristics with high efficiency as compared to an induction motor (Lee, Seok and Ahn, 2009).

### 2. Proposed system configuration

The schematic of the proposed SPV array fed water pumping system using SRM drive is shown in Figure 1. The complete design, control and performance analysis of a present system are elaborated in the following sections. All rated and calculated values for each part of proposed system is also given in Appendix.

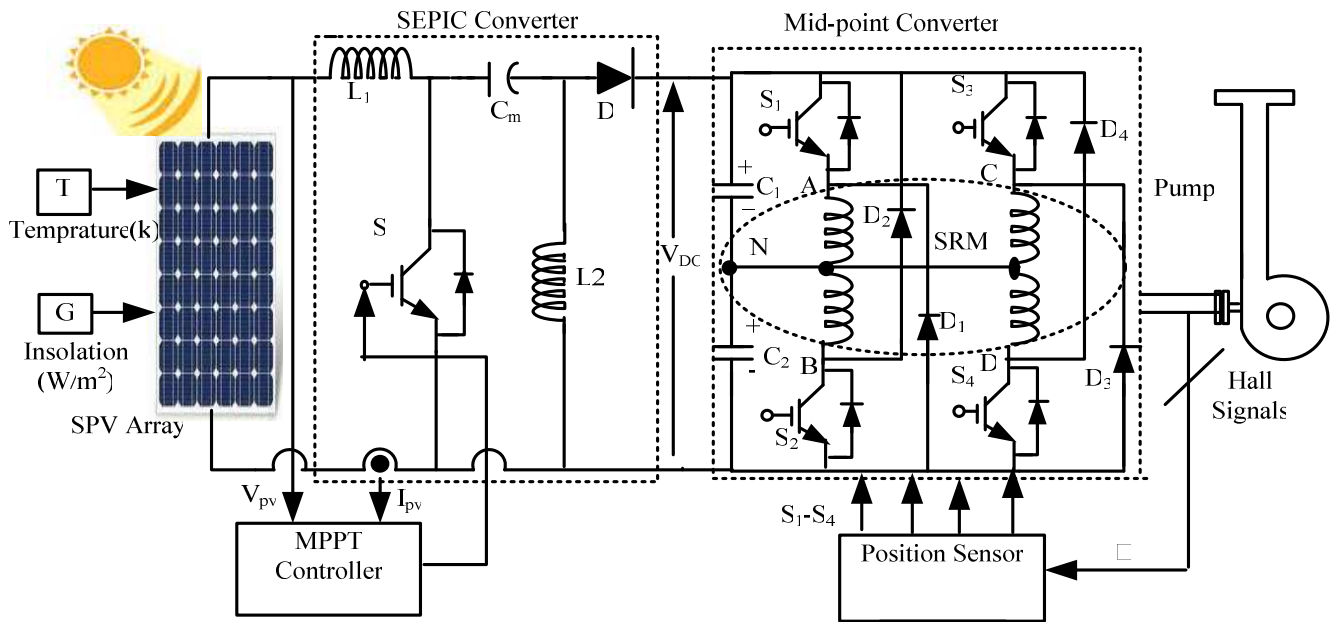

Figure 1. Schematic diagram of standalone solar PV based SRM drive for water pumping system.

### 3. Operation of proposed system

The characteristics like stable output power and very small ripples at maximum power as compared to the Ćuk or other buck-boost converters, SEPIC converter becomes an admirable candidate for proposed system (Singh and Singh, 2010). Figure 2(a) shows a circuit diagram of a proposed system. The operation of proposed system is classified into three different modes corresponding to switch turn- OFF, switch turn-ON, and CCM operation of SEPIC converter. These modes are shown in Figures 2(b)–(d) and their associated waveforms are shown in Figure 2(e).

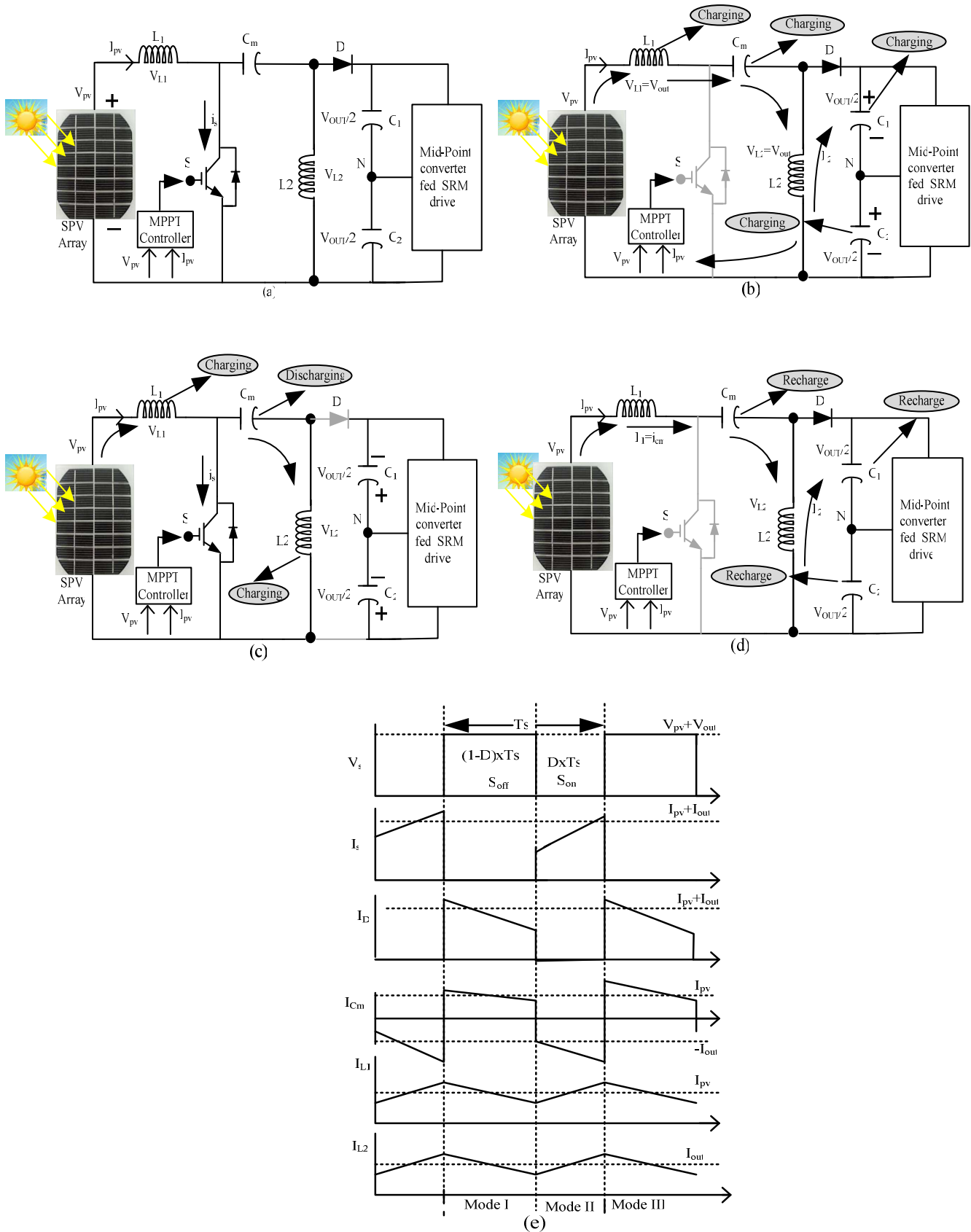

Figure 2. (a) Basic circuit. (b-d) Different modes of operation (Mode-1 to Mode-3) and (e) the associated waveforms.

#### 4. Control of proposed system

The maximum power of the SPV array is tracked using P & O MPPT technique and the mid-point converter feeding power to the SRM is operated through an electronic commutation. The fundamental switching rather a PWM switching of mid-point converter results in lower switching losses and better switches utilization. These controls at the various stages are discussed briefly in the following sub-sections.

**4.1 MPPT technique:** To mitigate the mismatch problem between load and SPV array, a tracker called MPPT is used to operate SPV array operation at maximum power point (MPP). The performance of Perturb and observe (P & O) algorithm for MPPT control is affected by its step size and perturbation frequency (Sharma and Purohit, 2012; Sullivan and Powers, 1993). It is the simple algorithm that does not need the knowledge of previous characteristics of SPV array.

**4.2 Control of SRM:** SRM rotor has no windings, magnets or cage winding but it is built up from a stack of salient-pole laminations. The switching angles are defined for each phase based on the rotor position information provided by a Hall-sensor located on the stator part of motor (Krishnamurthy, Edrington and Fahimi, 2006). The starting angle or  $\theta_{on}$  for SRM is chosen to permit the current to grow to an adequate level while rate rise of the inductance is at its minimum value. The error between the sensed and ideal value of  $\theta$  index is due to the position placement errors of Hall sensors and their magnetic field distortions which is discussed in (Rajesh and Singh, 2012). The mid-point converter configuration containing SRM windings is shown in Figure 3.

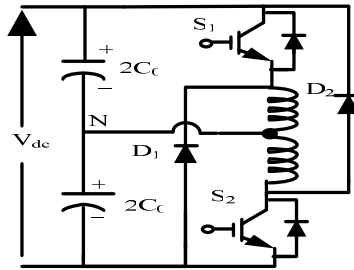

**Figure 3.** Mid-point converter with SRM windings.

#### 5. Design of proposed system

The complete calculations with proper value selection of components at the various stages of proposed system are discussed in the following sub-sections. A 3.9 kW power rating centrifugal water pump somewhat smaller rating compare to SRM motor is selected for present system.

**5.1 Design of SPV array:** A 4.8 kW peak power capacity of SPV array system somewhat higher than motor power rating is taken for proposed system by assuming some losses take place in DC-DC and mid-point converters. Numbers of series and parallel PV cells connected in module are 12 and 2 respectively and with maximum power at 85% of open circuit voltage and 85% of short circuit current as discussed in (Kishor, Mohanty, Villalva and Ruppert, 2010). The design of PV module and PV array parameters with calculated values are given in Table 1.

**5.2 Design of SEPIC converter:** Single-ended primary inductance converter (SEPIC) is able to regulate the output voltage higher or lower than input voltage with same polarity. The SEPIC converter transfers the energy from SPV array side to load side utilizing energy transfer capacitor,  $C_m$ . The SEPIC converter is so designed that it always operates in continuous conduction mode (CCM) regardless of the atmospheric conditions. The SEPIC converter achieves high power density and fast transient response when operated at high switching frequency (Singh and Singh, 2010). It is designed for constant current in the intermediate inductor ( $L_2$ ) as it operates on the principle of an inductive energy transfer. The boost inductor ( $L_1$ ), and capacitors ( $C_m, C_{1,2}$ ) are designed according to maximum permissible current and voltage ripple during transient conditions of the SRM drive.

**Table 1.** Calculated value of SPV array

PV Module	
Open circuit voltage, $V_{oc}$	32.9 V
Short circuit current, $I_{sc}$	8.21 A
Voltage at MPP, $V_m$	26.3 V
Current at MPP, $I_m$	7.61 A
PV array	
Voltage at MPP, $V_{mp}=V_{pv}$	315.6 V
Power at MPP, $P_{mp}$	4.8kW
Current at MPP, $I_{mp}=I_{pv}$	$P_{mp} / V_{mp} = 15.20$ A
Number of modules connected in series, $n_s$	$V_{mp} / V_m=12$
Number of modules connected in parallel, $n_p$	$I_{mp} / I_m = 2$

Considering, peak-to-peak ripple current in both input inductor,  $L_1$  and output inductor,  $L_2$  is  $\Delta i_1$  and  $\Delta i_2$  respectively and approximated as 20% of the maximum current of the currents flowing through  $L_1$  and  $L_2$ ,  $f_{sw} = 40$  kHz where ' $f_{sw}$ ' is the switching frequency, ' $V_0$ ' is the output voltage of the SEPIC converter taken as 605 V. ' $D$ ' is the duty cycle, ' $I_{pv}$ ' is the input current of the SEPIC converter and ' $\Delta V_{cm}$ ' is ripple in the voltage across ' $C_m$ ' (10% of  $V_{cm}$ ).

The phase current 'I' is given as,

$$I = \frac{P}{V_{dc}} = \frac{4800}{605} = 7.93A \tag{1}$$

The required calculations for SEPIC converter with values used in simulations are provided in Table 2.

**Table 2.** Calculated value of SEPIC converter parameters

Parameters	Expressions	Design data	Value
Input Inductor, $L_1$	$L_1 = \frac{V_{mpp} \times D}{\Delta i_1 \times f_{sw}}$	$L_1 = \frac{315.6 \times 0.66}{(3.04 \times 40 \times 10^3)}$	2.69mH
Output Inductor, $L_2$	$L_2 = \frac{(1 - D) V_0}{\Delta i_2 \times f_{sw}}$	$L_2 = \frac{605(1 - 0.66)}{(1.58 \times 40 \times 10^3)}$	5.25mH
Energy Transfer Capacitor, $C_m$	$C_m = \frac{I_{in}(1 - D)}{(\Delta V_{cm}) \times f_{sw}}$	$C_m = \frac{15.2(10.66)}{(92.83 \times 40 \times 10^3)}$	2.23μF
DC link split capacitors, $C_1$ & $C_2$	$C_1 = C_2 = \frac{I(30 - \alpha)}{2\omega \Delta V_{dc}}$	$C_1 = C_2 = \frac{7.93 \times (30 - 15)}{(2 \times 6 \times 1500 \times 3.025)}$	2100 μF

5.3 Design of centrifugal water pump: The characteristic of the centrifugal water pump and its relation between output power and mechanical speed of motor is defined as,

$$P_p = K_p \omega^3 \tag{2}$$

At steady state, electromagnetic torque,  $T_e$  of SRM motor equilibrates the mechanical torque  $T_p$  of the load coupled to the shaft of the motor. The centrifugal water pump is designed using its torque-speed relationship as,

$$T_p = K_p \omega^2 \tag{3}$$

where  $K_p$  is the proportionality constant and it is estimated as,

$$K = T_p / \omega^2 = 25 / 157.08^2 = 0.001 \tag{4}$$

These data are used to develop the Matlab/Simulink model of the system.

### 6. Results and discussion

The proposed SPV array fed water pumping system is analyzed under different operating conditions and recognized in terms of SPV array voltage,  $V_{pv}$ , SPV array currents,  $I_{pv}$ , SPV array power,  $P$ , input inductor current,  $I_{L1}$ , output inductor current,  $I_{L2}$ , voltage across energy transfer capacitor,  $V_{Cm}$ , voltage across DC link capacitors,  $V_{c1}$  and  $V_{c2}$ , switch voltage and current  $V_{sw}$  and  $I_{sw}$ , phase currents,  $I_1, I_2, I_3, I_4$ , resultant torque of SRM,  $T_e$ , SRM speed,  $N$ , and water pump load torque,  $T_p$ .

6.1: *Performance of proposed system under fixed solar irradiance level:* Figures.4-5 demonstrate the characteristics of current, voltage and power of the SPV array and SEPIC converter in both starting and in steady state conditions. SPV array is supplying desired  $V_{pv}$  and  $I_{pv}$  value after some time due to the delay in tracking process of MPPT algorithm. The current of both inductors  $L_1$  and  $L_2$  are in CCM mode and provides minimal switching stress for both at starting and in steady state conditions. Both split capacitors of mid-point converter are showing similar charging and discharging characteristics. Figures.6 and 7 define the nature of currents and torque's in both starting and in steady state conditions across each phase of SRM.

6.2: *Performance evaluation of proposed system under varying solar irradiance level:* Figure 8 exhibits that  $V_{pv}$  of SPV array is regulated and control by MPPT controlled and its value remains fixed under both transient and steady state conditions at different level of irradiance. Switch voltage, switch current,  $I_{pv}$  and 'P' are showing changeable behavior with solar irradiance level. Figure 9 illustrates that the SRM indices vary with solar irradiance level and reach their rated value under steady state conditions. Figure 8 explains the behavior of SPV array and SEPIC converter parameters for two different values of insolation level that are  $450W/m^2$  and  $1000 W/m^2$  respectively. Figure 9 also concludes that the torque and speed of SRM are strongly depending upon the insolation levels.

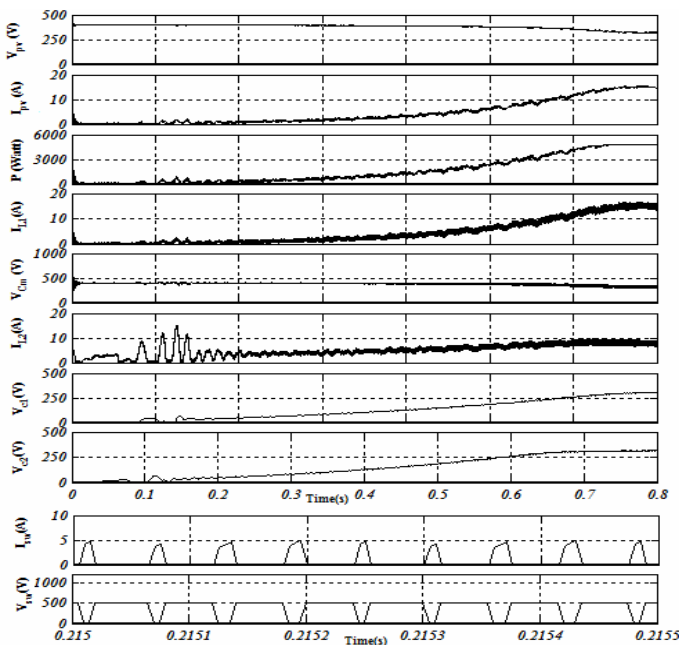

Figure 4. Performance of SPV and converter parameters state. during starting condition.

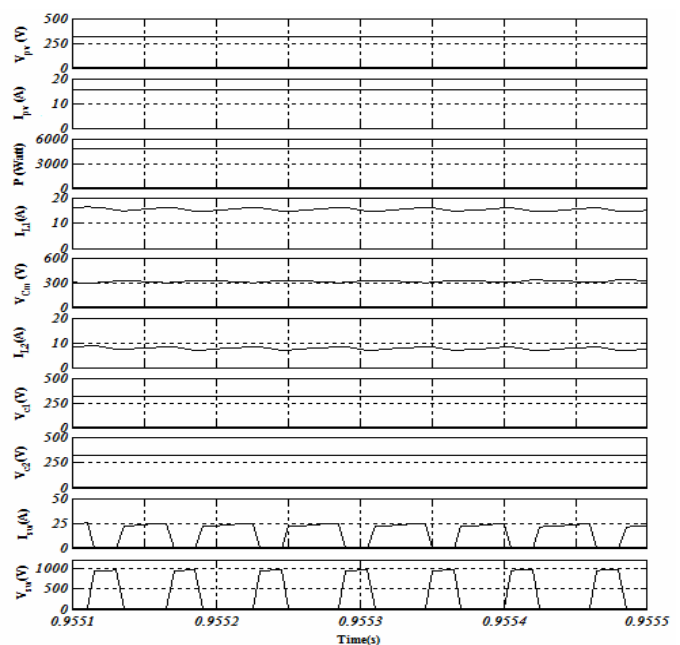

Figure 5. SPV and SEPIC parameters response during steady state.

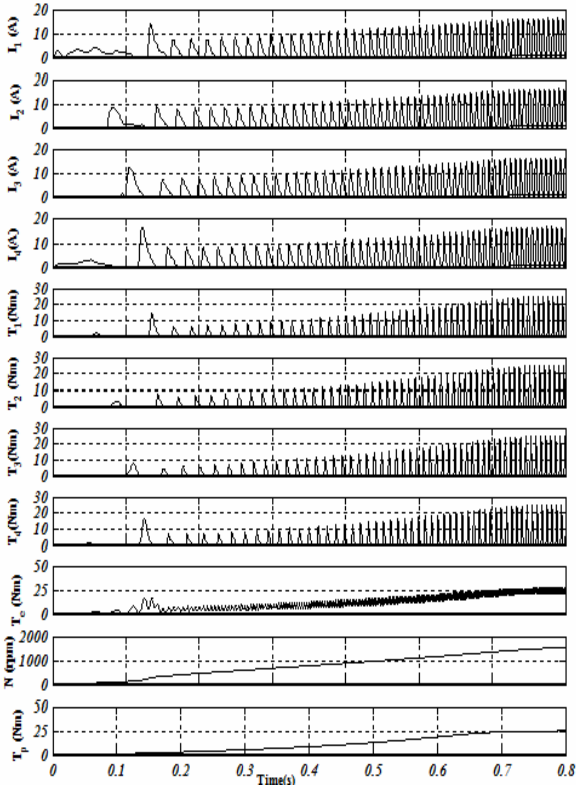

Figure 6 Performance of motor current, torque and speed during starting condition.

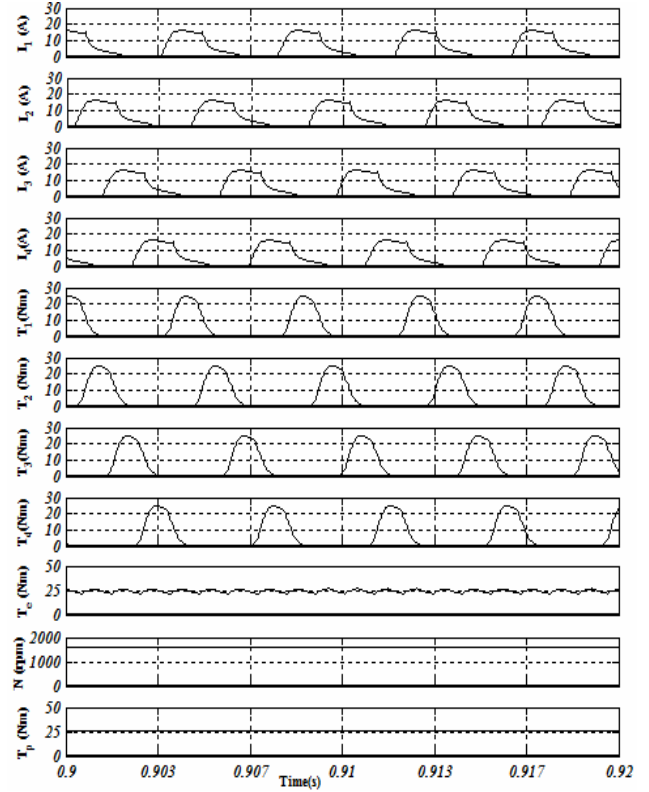

Figure 7 SRM behavior during steady state and at fixed insolation level.

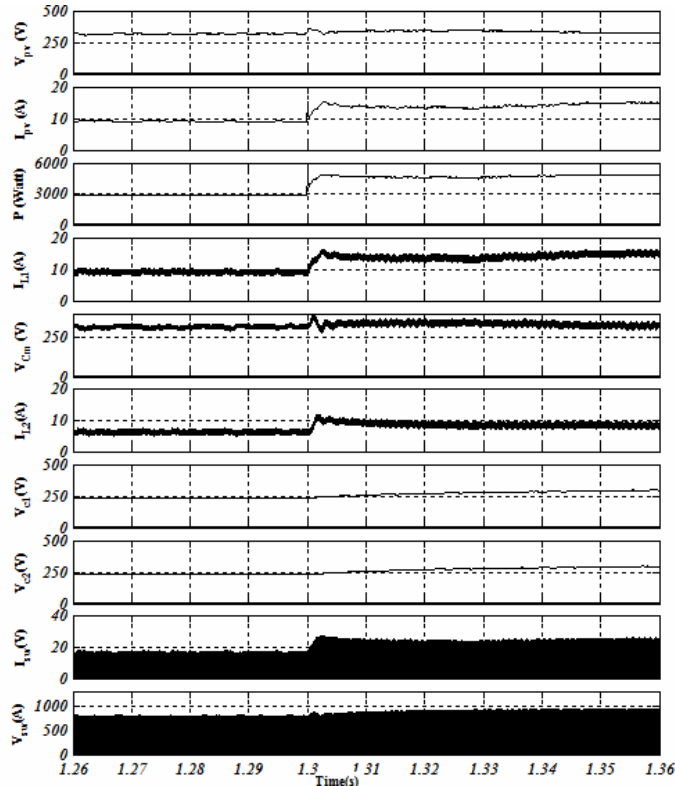

Figure 8 Performance of SPV and SEPIC converter indices at Transient and steady state for different irradiance levels.

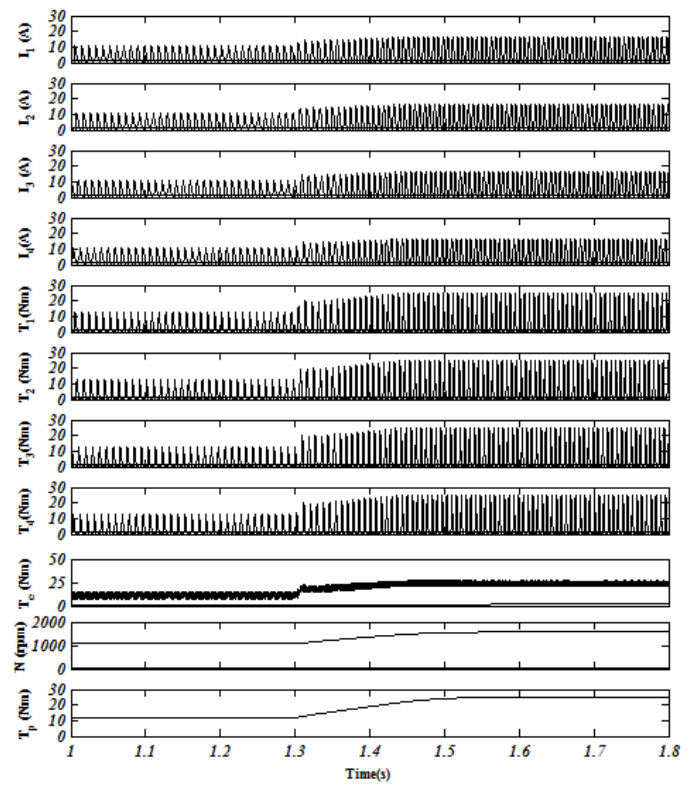

Figure 9 Performance of motor at transient and steady state conditions.

## 7. Conclusions

The variable DC link voltage control of SRM drive with fundamental switching for mid-point converter has been used in the proposed model of SPV fed water pumping system. As a result, the system becomes highly reliable, rugged and efficient. The SEPIC converter in CCM mode is used as an intermediate converter between PV system and the motor which provides favorable conditions for a MPPT tracking operation. The proposed system has been analyzed through starting, dynamic and steady state performances under all possible environment conditions.

## Appendix

### A. Switched Reluctance Motor Specifications:

4kW, 8/6pole, 1500rpm,  $R$  (Phase Resistance) = 0.7  $\Omega$ ,  $L_u$  (unaligned inductance) = 12mH,  $L_a$  (aligned inductance) = 110mH,  $J=0.016\text{kg-m}^2$ ,  $B=0.0065\text{Nms}$ .

### B. Selected Parameters of Solar PV Array

Open circuit voltage of module,  $V_{oc} = 32.9$  V; Short circuit current,  $I_{sc} = 8.21$  A; Maximum power,  $P_{mp} = 4.8$  kW; Voltage of array at MPP,  $V_{mp} = 315.6$  V; Current of array at MPP,  $I_{mp} = 15.2$ A; Numbers of modules connected in series,  $n_s = 12$ ; Numbers of modules connected in parallel,  $n_p = 2$ .

### C. Parameter Selection for Design of SEPIC Converter

Switching frequency,  $f_{sw} = 40$  kHz; Inductors,  $L_1 = 2.69$  mH; &  $L_2 = 5.25$  mH, Energy Transfer Capacitor,  $C_m = 2.23\mu\text{F}$ , DC link split capacitors,  $C_1 = C_2 = 2100$   $\mu\text{F}$ .

## Acknowledgement

Authors thank to the Department of Science and Technology (DST), Govt. of India, for all encouragement and support for this work under Grant Number: RP02926.

## References

- Hussein K., I. T. Hoshino Muta., and Osakada M., 1995. Maximum photovoltaic power tracking: An algorithm for rapidly changing atmosphere conditions, Proc. Inst. Elect. Eng. G, vol. 142, pp. 59–64.
- Johnson Jame L., 2004. *Introduction to Fluid Power, Science & Technology*, Delmar Cengage Learning.
- Kishor N., Mohanty S.R., Villalva M.G. and Ruppert E., 2010. Simulation of PV array output power for modified PV cell model. *IEEE International Conference on Power and Energy (PECon)*, pp.533-538.
- Krishnamurthy Mahesh, Edrington chris S., and Fahimi Babak, 2006. Prediction of Rotor Position at Standstill and Rotating Shaft Conditions in Switched Reluctance Machines, *IEEE Transactions On Power Electronics*, vol. 21, no. 1, pp 225-233.
- Krishnan R., 2001. *Switched Reluctance Motor Drives: modeling, simulation, analysis, design and applications*, CRC Press, 2001.
- Lee D.H.; Seok S.H. and Ahn J.W., 2009. SR drive for hydraulic pump using a novel passive boost converter, *IEEE Energy Conversion Congress and Exposition, ECCE 2009*, pp.282, 287.
- Rajesh M. and Singh B., 2012. Power quality improvement in switched reluctance motor drive using Vienna rectifier, *IEEE Fifth Power India Conference*, , vol., no., 22 pp.1,7, 19 .
- Singh S. and Singh B., 2010. Voltage controlled PFC SEPIC converter fed PMBLDCM drive for an air-conditioner, *Power Electronics, Drives and Energy Systems (PEDES) & Power India, Joint International Conference*, vol., no., pp.1,6.20-23 .
- Sharma D.K. and Purohit G., 2012. Advanced perturbation and observation (P&O) based maximum power point tracking (MPPT) of a solar photo-voltaic system, *IEEE 5th India International Conference on Power Electronics (IICPE)*, vol., no., pp.1, 5,
- Sullivan C.R. and Powers M.J., 1993. A high-efficiency maximum power point tracker for photovoltaic arrays in a solar-powered race vehicle, *24th Annual IEEE Power Electronics Specialists Conference, PESC '93 Record*, pp.574,580, 20-24 Jun .

## Biographical notes

**Bhim Singh** (SM'99–F'10) received the Bachelor of Engineering (Electrical) degree from the University of Roorkee, Roorkee, India, in 1977 and the M.Tech. and Ph.D. degrees from the Indian Institute of Technology (IIT) Delhi, New Delhi, India, in 1979 and 1983, respectively. In 1983, he joined the Department of Electrical Engineering, University of Roorkee, as a Lecturer. He became a Reader there in 1988. In December 1990, he joined the Department of Electrical Engineering, IIT Delhi, as an Assistant Professor, where he became an Associate Professor in 1994 and a Professor in 1997. He has guided 50 Ph.D. dissertations and 150 M.E./M.Tech. theses. He has been granted one U.S. patent and filed ten Indian patents. He has executed more than 70 sponsored and consultancy projects. His fields of research interest include power electronics, electrical machines, electric drives, power quality, flexible ac transmission systems, high-voltage-direct-



current transmission systems, and renewable energy generation. Prof. Singh is a Fellow of the Indian National Academy of Engineering, the National Science Academy, the Indian Academy of Science, the Institute of Engineering and Technology, U.K., the Institution of Engineers (India), the World Academy of Sciences (FTWAS), the Indian National Science Academy, and the Institution of Electronics and Telecommunication Engineers.

**Anjaneer Kumar Mishra** received the Bachelor of Technology degree in Electrical and Electronics Engineering from G.B.T.U. Lucknow, India in 2007. In 2011, he joined the college SRMCEM, Lucknow as Lecturer in electrical engineering department. Currently, he is working toward the M.Tech degree in the Department of Electrical Engineering, Indian Institute of Technology–Delhi, New Delhi, India.

Received March 2015

Accepted July 2015

Final acceptance in revised form July 2015