

Development of Microcontroller Based Water Quality Monitoring and Water Level Control Device

¹Nnamdi S. Okomba, ²Adebimpe O. Esan, ³Bolaji A. Omodunbi, ⁴Sobowale A. Adedayo, ⁵Fajimi D. Iyoaye, ⁶Lois O. Nwobodo, ⁷Ujunwa I. Nduanya

^{1,2,3,4,5}Department of Computer Engineering, Federal University Oye-Ekiti, Ekiti State, Nigeria

^{6,7}Department of Computer Engineering, Enugu State University of Science and Technology, Enugu State, Nigeria

nnamdi.okomba|adebimpe.esan|bolaji.omodunbi|iyoyaye.fajimi.1031@fuoye.edu.ng|sobowaleadedayo@gmail.com|lois.nwobodo|uju.nduanya@esut.edu.ng

Received: 29-FEB-2024; Reviewed: 04-MARCH-2024; Accepted: 22-MARCH-2024

<https://dx.doi.org/10.4314/fuoyejet.v9i1.7>

ORIGINAL RESEARCH

Abstract- Access to clean and safe water is not only a fundamental human right but also a vital requirement for electronics industries, chemicals industries, pharmaceuticals, food and beverage production, fisheries and aquatic farming. This project addresses the pressing issue of water quality monitoring and efficient water usage within the context of these industries. The study's identification of problem areas for water quality can lead to more efficient interventions and solutions to safeguard the environment, and prevent waterborne diseases. This paper presents the design and implementation of microcontroller-based system for monitoring water quality and water level in the tank, the water in the tank is refilled when it goes beyond a set threshold with the aid of an automatic switch control. The system is a hybrid of 3 subsystems: a Water Level Checker, a Water Quality Monitoring System and an Automatic Switch control system. The Water level checker consists of Ultrasonic sensors. The Water Quality Monitoring system consists of pH sensors, TDS (Total Dissolved Solids) sensors and Turbidity sensors. The continuous (Analog) data from the water quality sensors used would be outputted via an LCD (Liquid Crystal Display). The Automatic Switch control system consists of 5v Relay modules and a 12v Pump that would automatically switch ON/OFF depending on the level of water in the tank. The values of EC (Electrical Conductivity) and TDS spike drastically to the introduction of salt from as low as 138 -906 for TDS and 0.34 – 2.04 for EC, signifying increase in water capacity of electrical conductivity. Temperature rise in the afternoon also increases TDS values from 142 for clean water to 920 for the salty water while it ranges from 138 for clean water to 906 for salt water at both morning and evening time. Pumping aspects of the system are triggered when water level in the tank falls below 10% and trips off when water level goes above 95% as programmed in the control unit. The developed system marks a significant achievement in water management and automation technology. integration of quality monitoring sensors has enabled real-time evaluation of water parameters that holds potential for applications in environmental monitoring, ensuring safe drinking water, and safeguarding aquatic ecosystems. The automated switch control mechanism responds dynamically to water levels, enabling the system to trigger actions such as pump activation or filling processes based on predefined thresholds.

Keywords— Pump switching, pH, Relays, Solenoid Valves, TDS, Turbidity.

1 INTRODUCTION

Approximately 1% of water resources, including rivers, lakes, and oceans, are utilized for various human activities such as water supply, irrigation, and recreation. However, the continuous increase in population has led to the pollution of these water resources by various contaminants, including wastes, and agricultural fertilizers (Hutton, 2012). The physical, chemical, and biological properties of these water resources must be regularly monitored to ensure they remain safe for use. Consequently, there is a critical need for an efficient water quality monitoring system that can effectively assess water quality in specific areas and fields

such as for electronics industries, chemicals industries, pharmaceuticals, Food and Beverage Production, fisheries and aquatic farming (Abdolmajid and Mehraban, 2014).

Periodic water monitoring activities are essential to minimize the detrimental effects of pollution on both the local community and aquatic ecosystems. Monitoring water quality in the 21st century is a growing challenge due to the vast number of chemicals used in our everyday lives and industry that can find their way into our waters (Banna et al, 2014). Methods of chemical analysis and knowledge of chemical toxicity are available for just a few thousand of the more than 80,000 chemical substances reported by EPA for commercial use in the United States.

Traditional methods of water quality monitoring typically involve manual collection of water samples from multiple locations. Existing water quality monitoring technologies are often labor-intensive, time-consuming to set up, and expensive (Andrew et al, 1995). Additionally, their large size can pose transportation challenges, especially in remote and expansive monitoring areas. Furthermore, these instruments often require operation

*Corresponding Author

Section B- ELECTRICAL/COMPUTER ENGINEERING & RELATED SCIENCES

Can be cited as:

Okomba N.S., Esan O.A., Omodunbi B.A., Sobowale S.A., Iyoaya F.D., Nwobodo N.O., and Nduanya U.I. (2024).

Development of Microcontroller Based Water Quality Monitoring and Water Level Control Device, FUOYE Journal of Engineering and Technology (FUOYEJET), 9(1), 43-48.

<https://dx.doi.org/10.4314/fuoyejet.v9i1.7>

by experienced users. Moreover, in today's technologically advanced world, water machines have become a necessity in everyday life, particularly within communities where smart home appliances play a significant role. Many types and sizes of water machines are available to the public, but they often lack efficiency. The primary issue is the lack of automatic shut-off mechanisms when the water tank is full. This inefficiency leads to unnecessary electricity consumption and wastage of water resources. To address this problem, a water quality and level control system was designed and implemented. This system will utilize a microcontroller (Arduino UNO), ultrasonic sensor, and other necessary components to automatically turn off the pumping system when the water tank is full, thus creating a convenient and suitable means for monitoring water quality and optimizing water machine efficiency.

2 RELATED WORKS

Akanksha and Ulhaskumar, (2014), talks about a water quality measuring system that makes use of multiple sensors, information acquisition module and data transmission module. Information acquisition module includes microcontroller 8051. Data transmission module includes GSM module. There are numerous sensors that measure temperature, turbidity, pH, conductivity and total dissolved solid present in the water. This technique conjointly uses ADC. The measured values are then transmitted to the watching center via GSM; it's conjointly shown on LCD by the microcontroller. The system has the advantage of potency, accuracy and low price. Major components used in this project included GSM SIM 300 Module, micro-controller 8051.

Prasad et al, (2015) worked on smart water quality monitoring system. The paper was primarily divided into sub-tasks. The first task and a very integral one was to determine which water parameters would provide a close indication for water pollution. The second step was the selection of locales that will provide useful data. The third obstacle was which form of data logging would produce an acceptable format. A File Transfer Protocol (FTP) solution was developed initially on a local network, however without the intervention of local Internet Service Providers this seemed like the least convenient option. The final step was to decide on an acceptable, proficient and accurate form of analysis. Primarily parameters identified includes pH, TDS, Temperature. The Project was used to monitor water from 4 major sources, the chosen water types were seawater, surface water, tap water and polluted creek water and their results tabulated in the paper.

Vijayakumar and Aravindhan (2016) proposed an automatic water level controller and motor pump starter using GSM. The problem statement was the manual control of water level in tanks and the need for a remote monitoring and control system. The proposed system uses a GSM-based system to detect the water level in the tank and control the pump accordingly.

Geetha and Gouthami. (2017), talked about a revolutionary technology called ZigBee. This is a wireless

network data transport technology. It is made for multichannel control systems, alarm systems, and lighting control, and it uses less energy. Long-range communication protocols like 3G and the Internet are used for communication between the controller and the central data store. The controller in this paper's model, the TI CC3200, has an integrated Wi-Fi module and an ARM MCU specifically designed for wireless communication. Components like Temperature sensor, Turbidity sensor, PH sensor, Conductivity sensor, TI CC3200 controller were used in the development of this project.

Gaikwad and Vaishnavi (2017), also developed a Water Quality Monitoring System Based on IOT. In this implementation model ATMEGA 328 with Wi-Fi module was used. Inbuilt ADC and Wi-Fi module was used to connect the embedded device to internet. Sensors are connected to Arduino UNO board was used for monitoring and the ADC converts the corresponding sensor reading to its digital value and from that value the corresponding physiochemical parameter will be calculated. After sensing the data from different sensor devices, which are placed in particular area of interest. When a proper connection is made with the server device, the digital data will be delivered to the web server automatically.

Mohd et al, (2017) proposed a water quality monitoring system based on Raspberry Pi. The system uses various sensors to monitor parameters such as pH, temperature, and turbidity, and sends the data to a web server for storage and analysis. Okomba et al (2023) aimed to develop an IOT based solar powered pump for agricultural irrigation and control system using. Part of the problem statement was the inefficient use of water due to the lack of a smart water level management system. The proposed system uses IoT-based sensors to detect the water level in the tank and control the pump accordingly.

Joby et al (2020), developed an Aqua Monitoring System for Fish Farming, the methodology was based on IOT which detects the Dissolved oxygen level using pH sensor. The sensor range will be programmed in such a manner that if the level goes below the threshold, the pump for dissolved oxygen will be turned on with a relay. The system also detects the water level-Using Water level sensor such that if the water level does not reach the required level, the pump for pure water will be turned ON and lastly the system monitors water color via a webcam. History of this information is updated and monitored via a web application.

Arvin (2022), worked on the design of an Arduino based water quality monitoring system, the project is divided into hardware architecture and software details. In the hardware architecture, the creation of the circuit was constructed, and the prototype of the project was built. While in the software development, the whole complete prototype was operated via programming codes. The study was aimed to design an Arduino-based water quality monitoring system for smart agriculture. All the modules were created, and all the components were assembled. Major components used in this project

included ATmega328, ESP32, pH-4502c sensor, DS18B20 Temperature Sensor, Gravity Analog TDS (Electrical Conductivity) Sensor, Analog Turbidity Sensor.

Most existing systems on this field of study either focus on monitoring water quality or control of water pump to move water into the tank, but the developed system have the capacity to both monitor water quality and as well pump water to the tank once water has reduced architecture. Programming codes were used to operate the entire prototype during the software development process. Materials used for this system development Include: Arduino Uno, pH Sensor, TDS Sensor, Turbidity

beyond a set threshold. This technology can be applied by the bottle water manufacturing company.

3 MATERIALS AND METHODOLOGY

Hardware architecture and software specifics make up the two primary sections of this system design and implementation. The construction of the circuit and the construction of the prototype were done in the hardware

sensor, Solenoid valves, Relay modules, 12v Pump, Ultrasonic Sensor, and LCD Display. Fig 1 shows the architectural design of the developed system.

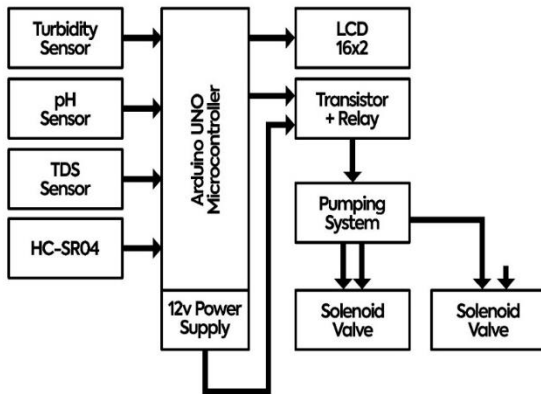

Fig.1 Architectural Design of the developed System:

The Hardware architecture would comprise majorly of Arduino Uno, and PC used for Arduino IDE. The LCD consists of 4 pins VCC connects to 5V, GND to GND, SDA (Serial Data) to A4, SCL (Serial Clock) to A5. All the variables used in the coding and the pins attached to each is defined. The values read from the sensors was taken from the pins, which are analog pins excluding ultrasonic and all the values displayed on LCD 16x2 screen.

The pH-4502c Sensor interface circuit comes with 6 male headers, out of all these pins, V+, P_o and one GND pin was

used. The sensor was calibrated to ensure absolute functionality, the probe connector's center and external part were connected in order to calibrate this sensor. A 2.5-volt tension is consequently created on the P_o analog output pin. The BNC probe connector center was joined to the external section of the BNC connector. Interfacing the Gravity Analog TDS (Electrical Conductivity) Sensor with Arduino is fairly simple. The VCC would be connected to Arduino 5V & GND to GND and finally connect its Analog pin (Ao) to any Arduino analog port.

Interfacing the Turbidity Module requires the use of a JST XH connector to connect the sensor itself to this module. There are three pins on it: output, ground, and VCC. Earth is wired to earth, and VCC is wired to the 5v. This module's output is an analogue value that fluctuates in accordance with the light level. Since this sensor only works with 5 volts, it cannot be implemented using a 3.3-volt control board.

While interfacing the HC-SR04 Sensor (Ultrasonic Module), the VCC pin was connected to the Arduino 5V pin and GND to GND. The other 2 pins on the sensor (Trigger and Echo pin) were connected to Pins 2,9,3,8 from the available 13 digital pins provided. Simple calculations were added to the coded program to convert the signals into distance values. Fig 2 and 3 shows the system flowchart and circuit diagram.

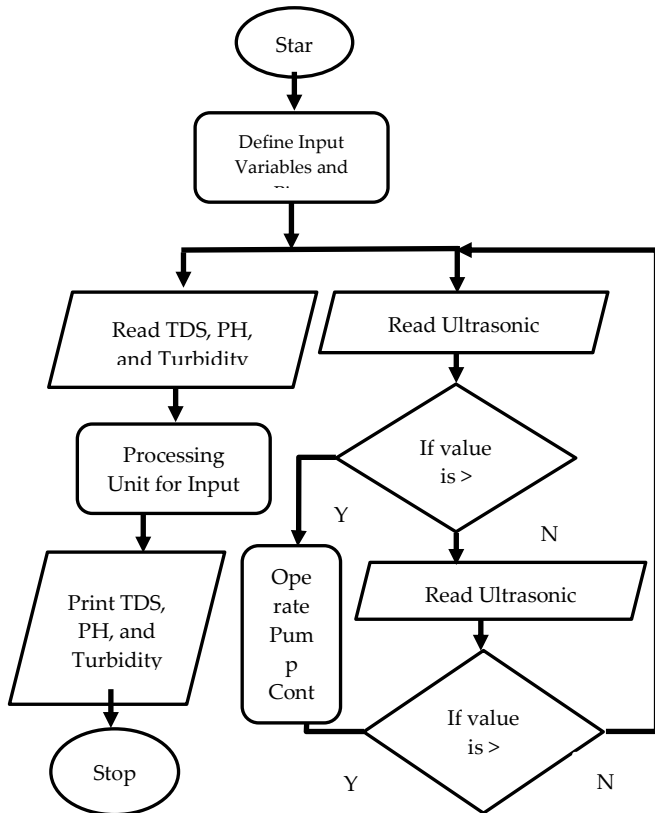

Fig 2: System Flowchart

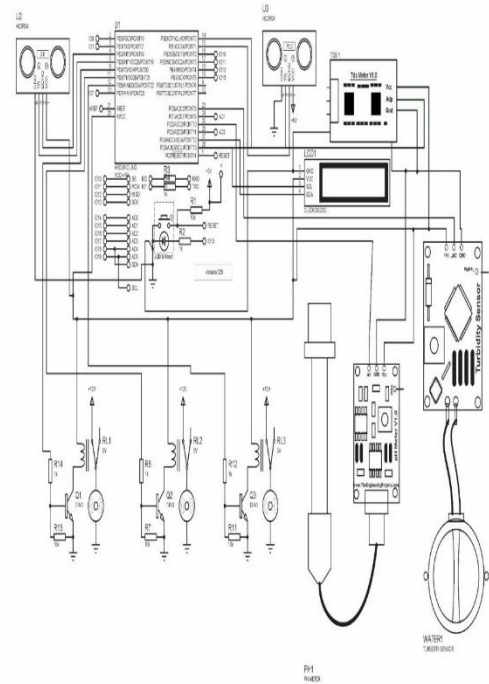

Fig 3. System Circuit Diagram

Interfacing the Arduino with Transistor Relay Module which consist of Transistor, Voltage divider and 5v relay is flexible. It has 6 Pins VCC, GND, IN, NO (Normally Open), NC (Normally Close), COM (Common). VCC connects to 5V, GND to GND. Three relays were used, and their IN's were connected to Pins 5,4,7 on the controller. A 12V solenoid valve was used to regulate liquid flow. An external power source was provided to power this component and it was triggered with the NO and COM ports of the relay module.

Table 1. Water Quality Results gotten in the Morning

	Turbidity	pH Level	TDS	EC
Regular Water	2-10	7.52-7.60	138- 140	0.34-0.35
Fish Water	300-335	8.1-9.0	348-501	0.86-1.23
Mud Water	1639-3000	7.8 – 9.6	811-846	1.96-
Salt Water	2-10	7.52-7.60	904-906	2.00-2.04

Table 2. Water Quality Results gotten in the afternoon after exposure to sunlight

	Turbidity	pH Level	TDS	EC
Regular Water	2-10	7.52-7.60	138- 140	0.34-
Water				0.35

4 RESULT AND DISCUSSION

The constructed system was tested using different types of water. Regular water, Salty water, Mud water and Pond water were all applied in the test and results collated and tabulated. Parameters being considered in the test include Turbidity, pH, Total Dissolved Solids (TDS), and Electrical Conductivity (EC) for the 4 types of water. Table 1, 2, and 3 shows the acquired results at different time of the day comprising morning, afternoon, and evening as the system is tested.

Regular Water	2-10	7.52-	142-	0.34-
Fish Water	300-335	8.1-9.0	358-	0.87-
Mud Water	1639-3000	7.8 –	818-	1.97-
Salt Water	2-10	7.52-	914-	2.01-
Water		7.60	920	2.04

Table 3. Water Quality Results gotten in the Evening after sun went down

	Turbidity	pH Level	TDS	EC
Regular Water	2-10	7.52-7.60	138- 140	0.34-
Water				0.35

Fish	300-335	8.1-9.0	350-500	0.86-
Water				1.23
Mud	1639-3000	7.8 – 9.6	813-848	1.96-
Water				1.98

Salt	2-10	7.52-7.60	905-906	2.00-
Water				2.04

All results gotten for the Mud water are completely dependent on the concentration of mud, the system being analog reacts instantly to any change in values. The Lower limit of the values are values after the Mud was diluted. The pH values for Mud water with concentration is between 8.6 - 9.6, diluting the Mud water with clean water reduces this value. The value also reduces when the Mud is allowed to sit and settle. The Varying of EC (Electrical Conductivity) does not reduce as drastic as other values though. The heat of the sun excites the molecules of the Mud water and increases the TDS values during afternoon time. The clean and salt waters Turbidity and pH values are unaffected, this is because both sodium and chlorine does impact acidity or alkalinity. This implies that Turbidity and pH values remain constant in both clean and salty water. The EC and TDS on the other hand reacts drastically to the introduction of salt, values spike from as low as 138 -906 for TDS and moves from 0.34 – 2.04 for EC, which shows the increase in the waters capacity to conduct electricity. Temperature also seems to affect the readings of TDS as the value increases in the afternoon through the water types ranging from 142 for clean water to 920 for the salty water while it ranges from 138 for clean water to 906 for salt water at both morning and evening time. Overall

Performance of the quality monitoring system seemed great, no overheating from any sensor, pH sensor values seem to spike in a funny way after type of water has been changed it balances and gives out correct values after about 3-4 seconds. Alternating between clean and mud water continuously seems to affect pH values even so slightly as contamination and dilution occur as probe exchange is done.

Considering the water level monitoring and automatic pump switching section of this work, after extensive testing, the system seems to respond well to change in water level which is good. The system output values in units of percentage (0-100%). Pumping aspects of the system are triggered when water level falls below 10% and trips off when water level goes above 95% as programmed in the control unit. Priority was given to TANK A such that if TANK A and TANK B are below 10% TANK A pumps first till its full before TANK B is pumped. If both TANKS are full the pump switches off accordingly. Below is a table 4, and 5 showing how the system stands at each condition, while figure 6 and 7 shows the system implementation unit and the image of the developed system.

Table 4. When Tank A or Tank B are below 10%

STATUS	<10%	11-95%	>95%
A	ON	ON	OFF
B	OFF	OFF	OFF

Table 5 When Tank A or Tank B are above 95 %

STATUS	<10%	11-95%	>95%
A	OFF	OFF	OFF
B	ON	ON	OFF

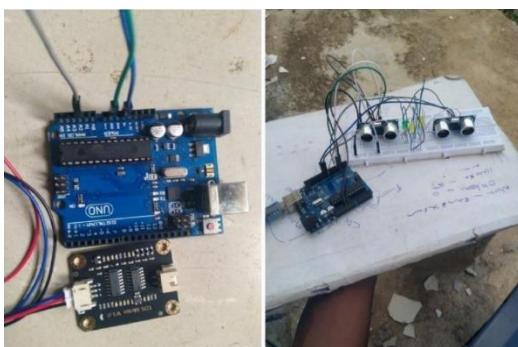

Fig 4. System Implementation Unit



Fig 5. Image of the Developed System

5 CONCLUSION

The developed system utilizes microcontroller-based sensors to accurately detect and monitor water levels in a targeted reservoir or container. This functionality holds immense promise in various sectors such as agriculture, irrigation, and industrial applications, where precise water level management is crucial for efficient resource utilization. The integration of quality monitoring sensors has enabled real-time evaluation of water parameters such as pH, turbidity, Total Dissolved Solids (TDS), and Electrical Conductivity (EC). This feature holds potential for applications in environmental monitoring, ensuring safe drinking water, and safeguarding aquatic ecosystems. The automated switch control mechanism

responds dynamically to water levels, enabling the system to trigger actions such as pump activation or filling processes based on predefined thresholds. This automation contributes to energy savings and operational efficiency by eliminating the need for constant manual oversight. In summary, the completion of the Design and Implementation of a Microcontroller-Based System for Monitoring of Water Level and Quality with Automatic Switch Control system marks a significant achievement in water management and automation technology. The knowledge gained from this endeavor serves as a foundation for continued advancements in water resource management and highlights the potential for future research and innovation.

REFERENCES

- [1]. Prasad, A. N., Mamun, K. A., Islam, F. R., and Haqva, H. (2015). Smart Water Quality Monitoring System, Conference: 2nd IEEE Asia Pacific World Congress on Computer Science and Engineering, Fiji Islands. DOI:[10.1109/APWCCSE.2015.7476234](https://doi.org/10.1109/APWCCSE.2015.7476234)
- [2]. Abdolmajid, F., and Mehraban, S. (2014). Evaluation and Assessment of Drinking Water Quality in Shahrekord, Iran, *Resources and Environment*, 4(3), 168-172. DOI: 10.5923/j.re.20140403.05
- [3]. Akanksha, P., and Ullhaskumar, G. (2014). Real Time Water Quality Measurement System based on GSM, *IOSR Journal of Electronics and Communication Engineering (IOSR-JECE)*, 9(3), 63-67. DOI:[10.9790/2834-09356367](https://doi.org/10.9790/2834-09356367)
- [4]. Arvin, S., and Araneta, D. (2022). Design of an Arduino-Based Water Quality Monitoring System. *IJCSCMC*, 11(3), 152-165. <https://doi.org/10.47760/ijcscmc.2022.v11i03.017>
- [5]. Banna, M. H., Imran, S., Francisque, A., Najjaran, H., Sadiq, R., Rodriguez, M., and Hoorfar, M. (2014). Online drinking water quality monitoring: Review on available and emerging technologies, *Critical Reviews in Environmental Science and Technology*, 44(12), 1370-1421. DOI:[10.1080/10643389.2013.781936](https://doi.org/10.1080/10643389.2013.781936)
- [6]. Gaikwad, M. A., and Vaishnavi, V. D. (2017). Water Quality Monitoring System Based on IOT, *Advances in Wireless and Mobile Communications*, 10(5), 1107-1116
- [7]. Mohd, A. J., Suthan, S., Wan, A. M., and Syed, Z. I. (2023). Water quality monitoring system using Raspberry Pi, *AIP Conference Proceedings*. [2608\(1\)](https://doi.org/10.1063/5.0129035), <https://doi.org/10.1063/5.0129035>
- [8]. Geetha, S., and Gouthami, S. (2017). Internet of things enabled real time water quality monitoring system, *Springer Smart Water, Open Access*, 2(1), 1-19, DOI 10.1186/s40713-017-0005-y
- [9]. Vijayakumar, M., and Aravindhan, K. (2016). Automatic water level controller and motor pump starter using GSM. *International Journal of Electrical and Electronics Research*, 4(2), 43-47.
- [10]. Hutton, G. (2012). Global costs and benefits of drinking-water supply and sanitation interventions to reach the MDG target and universal coverage. WHO/HSE/WSH/12.01. https://iris.who.int/bitstream/handle/10665/75140/WHO_HSE_WSH_12.01_eng.pdf?sequence=1
- [11]. Joby, T., Titus, T., Vishnu, V. J., Sivanesan, S., Rishi, M. (2021). Aqua Monitoring System for Fish Farming using Raspberry pi, *International Journal of Innovative Research in Science, Engineering and Technology (IJIRSET)*, 9(9), 8181-8185.
- [12]. Okomba, N. S., Esan, A. O., Omodunbi, B. A., Sobowale, A. A., Adanigbo, O. O., and Oguntuase, O. O. (2023). IOT BASED SOLAR POWERED PUMP FOR AGRICULTURAL IRRIGATION AND CONTROL SYSTEM, *FUDMA Journal of Sciences (FJS)*, 7(6), 192-199, DOI: <https://doi.org/10.33003/fjs-2023-0706-2056>
- [13]. Andrew, D. E., Lenore, S. C., and Arnold, E. G. (1995). *Standard Methods for the Examination of Water and Wastewater*, 19th edn. American Public Health Association, American Water Works Association and Water Environment Federation, Washington, DC, USA. https://beta-static.fishersci.com/content/dam/fishersci/en_US/documents/programs/scientific/technical-documents/white-papers/apha-water-testing-standard-methods-introduction-white-paper.pdf