



Bayero Journal of Pure and Applied Sciences, 12(2): 19 - 23

Received: June, 2019

Accepted: October, 2019

ISSN 2006 – 6996

MODIFICATION AND SIMULATION OF ASPHALT BLOWING UNIT (ABU) - HOT OIL SYSTEM

¹Adamu, M.S*, ¹Mohammed-Dabo, I.A., ¹Bilal, S. ¹Albert, G.Y. and ¹Mashi, A. H.

¹Department of Chemical Engineering, Ahmadu Bello University, Zaria-Nigeria

*Corresponding Author: muhammed_dm@yahoo.co.uk

ABSTRACT

This work focuses on the modification and simulation of asphalt blowing unit- hot oil system of Kaduna Refining and Petrochemical Company (KRPC). The modification involves an introduction of a 10-inch bye-pass line to the hot oil drum which helps in preventing oil loss and decrease heater duty for better efficiency and cost effective system. While the original and modified units were simulated using ASPEN HYSYS with the aim of observing the effect of temperature on the heater duty of the units and to determine the volume of hot oil lost from the hot oil drum due to flashing. After successful completion of the simulation, the amount of vapour lost per hour for the operational system was found to be 0.3853 m³, with a heater duty of 32240 kcal/hr while for the modified system is 0.3841 m³ and 11480 kcal/hr for amount of vapour loss and heater duty respectively. Prior to the modification, the oil is replenished at an interval of 48hrs which is totally avoidable. The introduction of bye-pass line helps to prevent oil loss and reduce heater duty by 64.40%.

Key words: Simulation, Hydrodesulphurization, Aspen Hysys, Impurities.

INTRODUCTION

Hot oils come from the lube cut and after further refining the hot oils are selected for viscosity (which partly defines the heat transfer properties) and stability. The Asphalt blowing unit of the Kaduna Refinery and Petrochemical Company has suffered a lot of setbacks in terms of heat transfer efficiency in the heater and the service heat exchangers. The constant loss of oil through flashing in the hot oil drum is another serious problem that needs attention this is because the storage drum serves as a flash drum instead.

However, hot oils are less thermally stable at elevated temperatures as they contain a certain degree of un-saturation (double bonds) and being more reactive chemically than more highly refined petroleum products, and are more susceptible to oxidative degradation.

The constant reduction in level of hot oil in the drum due to oil flashing constitute a major concern in the asphalt blowing unit of Kaduna refinery and petrochemical company, hence the need to investigate the major causes and to proffer solutions.

Prior to the modification, the oil is replenished at an interval of 48hrs which is totally avoidable.

The objectives of this work include: introduction of a 10 inch diameter pipe on the hot oil return line to bye-pass the hot oil expansion drum, simulation of the original and modified units,

and determination of the volume of hot oil lost from the drum due to flashing.

Asphalt is manufactured from petroleum and is a black or brown material that has a consistency varying from a viscous liquid to a glassy solid. To a point, asphalt can resemble bitumen, hence the tendency to refer to bitumen (incorrectly) as native asphalt. It is recommended that there be differentiation between asphalt (manufactured) and bitumen (naturally occurring) other than by use of the qualifying terms petroleum and native, since the origins of the materials may be reflected in the resulting physicochemical properties of the two types of materials. It is also necessary to distinguish between the asphalt which originates from petroleum by refining and the product in which the source of the asphalt is a material other than petroleum, e.g., wurtzite asphalt. In the absence of a qualifying word, it is assumed that the term asphalt refers to the product manufactured from petroleum.

When the asphalt is produced simply by the distillation of an asphaltic crude oil, the product can be referred to as residual asphalt or straight run asphalt. If the asphalt is prepared by solvent extraction of residua or by light hydrocarbon (propane) precipitation, or if blown or otherwise treated, the term should be modified accordingly to qualify the product (e.g., propane asphalt, blown asphalt).

Asphalt softens when heated and is elastic under certain conditions. The mechanical properties of asphalt are of particular significance when it is used as a binder or adhesive (James, 2006). Obtained from petroleum processes and insoluble in most pure hydrocarbons, raw asphalt has poor characteristic; high penetration, very low softening point and other qualities. Asphalt together with Resins (materials of similar composition but of linear polymers and hydrocarbons soluble) make up 5 – 15% of

Crude Oil. The oil fraction in asphalt is a mixture of oils similar to very heavy lube oils, resins are solids and semi solids.

The solid fraction is called Asphaltene which is responsible for the consistency of asphalt: the more the asphaltene content the higher the viscosity and softening point but the lower the penetration. Hence properties of asphalt vary over a wide range depending on the properties and the nature of the various constituents (Chiyoda, 1980).



Figure1: Pictorial View of KRPC Asphalt Blowing Unit (Adapted from KRPC Site)

Air blowing produces changes in asphalt by chemical reaction thereby improving on the penetration and softening point specifications. Therefore, blown asphalt is harder and brittle.

Crude Oil composition is vital in refining for asphalt because asphalt yield is practically set by Crude Oil composition while the quality is subject to processing, API gravity and carbon residue values can give a rough index of the amount of asphalt in Crude Air blowing feed as a blend of Furfural Extraction Unit (FEU) extracts (250N, 500N and Bright Stocks (BS)), Propane Asphalt (PAS) and Vacuum Residue -1 and -2 in a ratio which depends on the desired product asphalt quality (Chiyoda, 1980).

Aspen Hysys is a software for simulation of process plants and refineries connected to an extensive database, reliable thermodynamic models and rigorous equipment models, as well as tools for estimation of physical properties, liquid-vapour phase equilibrium, energy and material balances. ASPEN HYSYS facilitate the design, sizing, simulation and optimization of a chemical and/or a refinery plant and the required equipment (Bilal *et al.*, 2013).

A case can be transferred into a dynamic simulation where process controllers can be

added, and hence, realistically evaluate a plant wide control philosophy (Mohammad, 2009).

Shell Hot oil system is fitted with a control valve at the outlet of the hot oil drum to the circulation pump; this valve controls and prevents the already hot oil from the process stream from entering the drum. However, the valve is only open when the hot oil circulation depletes due to leakages or basically during start up. The object of this configuration is to prevent oil flashing in the drum (Shell, 2018).

The KRPC's has a trim cooler at the outlet of the heater which is mostly not efficient in reducing the temperature to prevent flashing. However, the unit was designed to feed three heat exchangers simultaneously but since inception, only one is used at a time.

MATERIALS AND METHODS

For Asphalt Blowing Process Unit to be simulated in HYSYS, there must be a foundation on which the components must be simulated. The Asphalt Feed and Air Streams components were selected as pure components within the simulation basis manager using "Components" tab while the "Hypotheticals" tab was used in creating Hot Oil Feed Component.

The next task was to add a fluid package, which is used by the software to calculate the component streams as they change within the HYSYS flow sheet. There is a pronounced danger of using an incorrect thermodynamics package because all processes involved; energy balance, volumetric flow rates and separation in the equilibrium-stage units depends on accurate thermodynamic data.

The Simulation environment contains the main flow sheet where majority of the work is done (installing and defining streams, unit operations, columns and sub flow sheets). Before entering the Simulation environment, a fluid package must be added to selected components in the component list.

The flow sheet in Aspen HYSYS shows the various components and the material streams needed to bring about the blowing of asphalt. It consists of various apparatus (Object Palette) but few objects we used are Conversion Reactor, Heat Exchanger, Tank, Pump, Heater, Compressor, Mixer, Valve and Recycle.

Process Description

The purpose of the hot oil system is to heat up the hot oil - one of distillates from Vacuum Distillation Unit (VDU-2) and supply it to the charge heater as a heating medium. The ABU Hot Oil Pump (28P10 A/B) pumps the feed to the ABU Hot Oil Heater (stream 16) through a flow rate control station. The hot oil enters the heater at about 270°C and flows through the

convection and radiant cell. Where the hot oil is heated up to about 316°C and sent to three charge heaters as a heating medium (stream 17). The flow of oil through the charge heaters is controlled by TIC on the process side, which resets a control valve between the supply and return lines at the end of the loop. After being cooled to about 260°C in the charge heater, the hot oil flows back to the hot oil drum (stream 19).

The flow rate of the hot oil into the charge heater is regulated by controlling the feed temperature into the oxidizer (C-01). And the circulation rate of the hot oil is controlled with a flow controller in proportion to the heating duty for each case of operation. In case of a process emergency, to prevent the heater outlet temperature from rising to a high level, a part of the oil is cooled down to about 200°C in a Hot Oil Cooler and mixed with the main oil. The hot oil cooler is also used to cool down the hot oil before being run down to the FCC charge tank when it needs to be replaced by fresh oil.

RESULTS AND DISCUSSION

Before modification

The simulated flow sheet of the asphalt blowing unit with the hot oil (stream 19) returning to the Hot oil drum as shown in Figure 2a. This system is said to favour flashing in the drum leading to oil lost and higher heater duty which also leads to high fuel consumption in firing the heater.

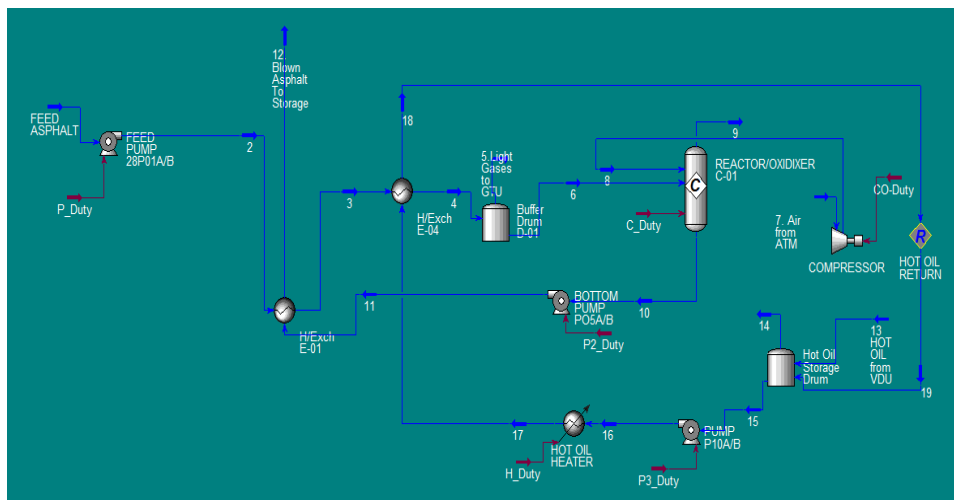

Figure 2a: Process flow diagram of the ABU (before modification)

After modification

Figure 2b. shows the modified simulated PFD of the asphalt blowing unit of the Kaduna refinery and petrochemical company. The hot oil drum is by-passed through a recycle stream with a mixer. The heat from the heat exchanger E04 is channeled through the pump to the heater; here -passed.

the temperature difference between the recycled stream and the set point (316°C) is small compared with the stream that passes through the storage drum to the heater. This arrangement reduces the heater duty and the fuel consumption. Oil lost due to flashing is avoided because the drum is by-passed.

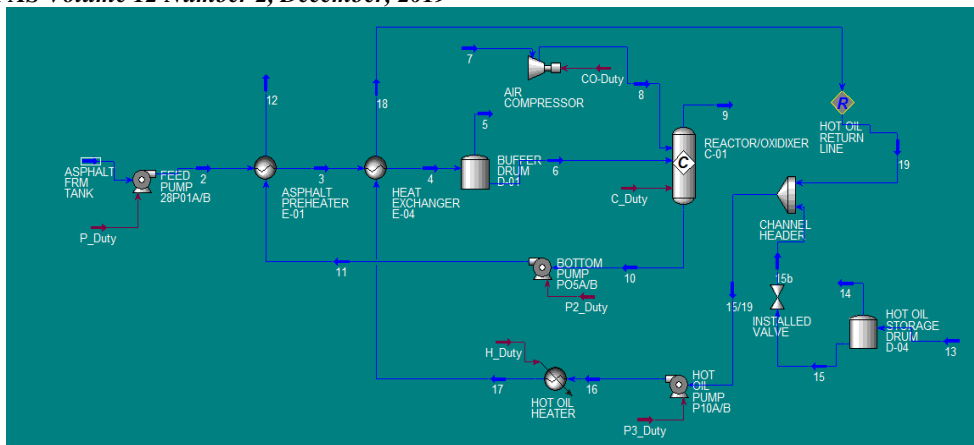

Figure 2b: Process flow diagram of the ABU (after modification)

Table 1: Relationship between temperature, oil loss and heater duty.

Temperature (°C)	Oil Loss (m ³ /hr)	Heat Exchanger Duty (kcal/hr)
260	0.3841	32240
270	0.3825	26630
280	0.3843	20950
290	0.3870	15200
300	0.3931	9379
310	0.4038	3486
316	0.4132	-83.35

As seen in Table 1, the higher the inlet temperature to the drum, the higher the oil lost due to flashing and the lower the heat exchanger duty. However, the higher the inlet oil temperature to the heater, the lower the heater duty and lower energy consumption and better heater efficiency.

Table 2: Comparing the Design, Operational and the Modified parameters

	Temperature (°C)	Duty (kcal/hr)	Amount of Vapour Loss (m ³ /hr)
Design	260.00	32240	0.3841
Operational	285.00	18090	0.3853
Modified	296.40	11480	0.3841

The initial Volume of oil in the drum = 90 m³ and Oil loss per day =9.2472 m³.

Table 2 gives the comparison between the design, operational and modified temperature, duty and amount of vapour loss. As seen in the table, the amount of vapour loss in both design and modified system is the same at 0.3841m³/hr

but in the long run the modified system will have a relatively lower vapour loss comparably because there is no additional heat into the drum. However, the existing operational system has a vapour loss of 0.3853 m³/hr which means that about 9.2472 m³ of the oil is lost each day.

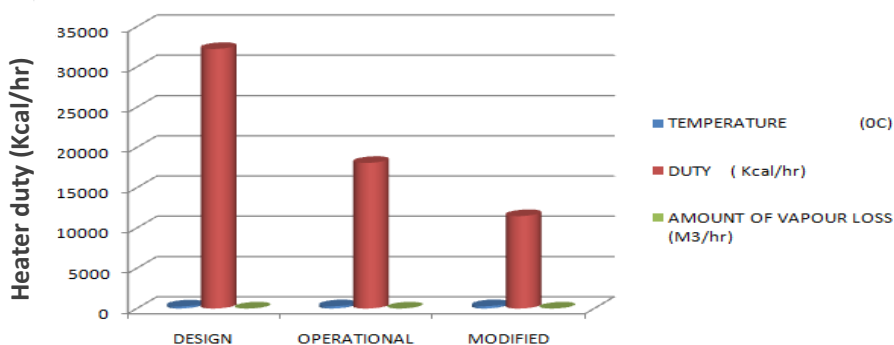

Figure 3: Relationship between the duty of designed, operational and the modified system.

Figure 3 shows the heater duty requirement for design, operational and modified system. The modified system has the lowest heater duty of 11480 kcal/hr, as against 32240 kcal/hr designed, the decrease in the heater duty reduces the fuel oil/gas consumption in the

heater because less heat is required to bring the hot oil to the required temperature of 316°C. The graph shows that, the higher the temperature in the drum, the more oil will be lost. This conforms to the literature at higher temperature, volatility increases (Coulson and Richardson, 2002).

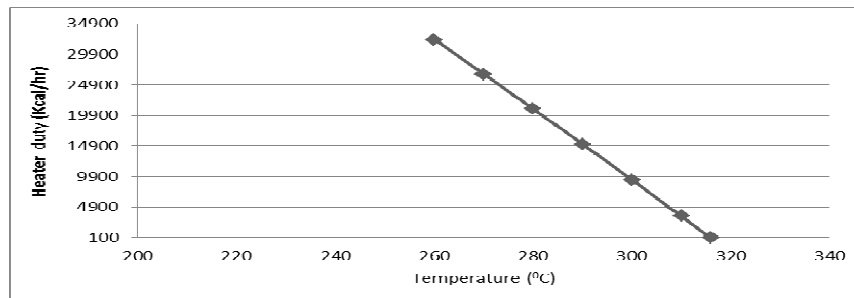

Figure 4: Heater Duty versus Temperature

Figure 4 shows a graph of duty against temperature. At higher inlet temperature, duty reduces and vice-versa, hence higher inlet temperature to the heater reduces fuel consumption because of the decrease in the temperature difference (ΔT). From the literature $Q=MC_p\Delta T$, the heater duty Q is a function of the temperature difference, ΔT . The smaller the value of Q , the smaller the ΔT at constant MC_p , and the lower the fuel consumption (www.webbustertz.org) Conclusively, the by-pass line to the hot oil drum helps to prevent oil loss due to flashing and increase heater performance by reducing the duty and decrease in fuel gas/oil consumption in the heater.

CONCLUSION

The Asphalt Blowing Unit, hot oil system of KPRC was successfully simulated and modified.

REFERENCES

- Bilal S., Mohammed Dabo I. A, Mujahid A. U., Kasim S., Nuhu M., Mohammed A., Abubakar H. M., Yahaya U. B., Habib A, Abubakar B., Aminu Y. Z. (2013). Simulation of Hydrodesulphurization Unit of Kaduna Refining and Petrochemical Company Limited. *Journal of Chemical and Process Engineering Research*. 13: 29-35.
- James G. Speight (2006). *The Chemistry and Technology of Petroleum* (4th Edition). Heinz Heinemann Berkeley, California. Inc. ISBN 1-4200-0838-2.
- www.webbustertz.org/how-to-calculate-the-heat-duty-for-heat-exchangers/15th November., 2018.
- Chiyoda Chemical Engineering and Construction Company limited, Yokohama, Japan (1980). *Process and Operating Manual*

The introduction of the by-pass return oil line to the storage drum helps in reducing oil loss due to flashing from 0.3853m³/hr to 0.3841m³/hr The heater duty reduces from 32240 kcal/hr to 11480 kcal/hr which reduces fuel consumption in the heater and enhance efficiency of the system. Lastly, about 9.2472 m³ of oil is lost per day to flare; this increases the cost of production/ operational cost.

RECOMMENDATION

The entire process units of the Refinery should be simulated in order to optimize the operations.

CONFLICT OF INTEREST

The authors declare that they have no conflicts of interest with the contents of this article.

for Asphalt Blowing Unit. Kaduna Refining and Petrochemical Company limited.

- Mohammad H. O., (2009), *Computer Aided Simulation and Process Design of a Hydrogenation Plant using ASPEN HYSYS 2006*, Past Master of Applied Science Research Thesis, Department of Chemical Engineering, University of Waterloo, Ontario, Canada.
- Coulson J.M. and Richardson J.F. (2002), *Chemical engineering. Vol. 2, Particle technology and separation processes*. Butterworth-Heinemann, Oxford.
- <http://www.iiste.org/Journals/index.php/CPER/article/view/6594>
- www.shell.com/refininingtechnologies/5th November, 2018.