



## DESIGN AND SIMULATION OF 120 CAPACITY AUTOMOBILE PARKING CONTROL SYSTEM USING UP/DOWN DECADE COUNTERS

Galadanci, G.S.M., Gana, S. M. and Aliyu, H.A.

Department of Physics, Bayero University P.M.B. 3011, Kano

Email: [gsmgalda@gmail.com](mailto:gsmgalda@gmail.com), [sgana@live.com](mailto:sgana@live.com), Tel: 08037260380, 08037504446

### ABSTRACT

*In this work, a 120 capacity automobile parking control system was designed and simulated. The design was carried out using 3-cascaded 74HC190 decade up/down counters in connection with MCT6 phototransistor optocoupler sensors, Gated S/R latch, LEDs display, logic gates and DC motor circuitry. The up/down counters were used for both up count from 1 to 120 and down count from 120 to 0. The sensors are placed at both the entry and exit gate of the parking lot in order to provide a pulse to the up/down counter whenever an automobile enters or leaves the parking lot. The DC motor circuitry is used to control the gate(entry gate) by closing the entry when the counter counts up to 120, so that no automobile will be allowed in. When one or more automobile leave(s) the parking lot through the exit gate the counter counts down, and the DC motor circuitry drives the entry gate open to allow access for the same number of automobiles that leave(s) the parking lot. The design was implemented and simulated using National instrument (multisim 11.0) and proteus softwares. The simulation results shows that the system functioned as desired.*

**Keywords:** Decade up/down counters, phototransistor optocoupler, Gated S/R latch, LEDs display, logic gates and DC motor circuitry.

### INTRODUCTION

The advancement and progress of nations is measured by the possibility of their use and application of latest invented technologies in all aspects of life. Control engineering is one of the aspects which have been given a great deal by many researchers (Wada et al, (2003); Pohl et al, (2006); Chandni et al, (2015)). It is quiet helpful to bring a means of monitoring a parking garage automatically rather than manually because of many reasons such as immediate and low delay in operation. Nigeria is a little backward in term of embracing such wonderful development like many other developing countries . Even though, in some part of the country similar system development are already in used, but most of which are imported rather than being developed in the country. Hence in view of the stated problems, there is a need to embark upon investigation on how to design and simulate an electronic automobile parking control system. Some years back people and organizations used heavy metal gates which require the use of human strength to open or close their garage. After the advent of digital electronics, much problems were overcome in many countries, including the problem stated above. This research focused and put more emphasis on our dear country to identify the need to inform or mobilize our community so as to have an idea on how to design and produce a digital automobile parking control system; which do not require the use of human strength to either uplift or shift the gate (no need to employ gateman), and is faster in operation, inexpensive, more reliable and qualitative in order to compete with other

developed countries and minimize importation of similar systems.

In this research work the design, implementation and simulation of an electronic automobile parking control system using discrete components that has the capacity of 120 parking space is presented (Galadanci *et. al.*, 2013). The design was carried out and implemented using simulation softwares multisim version 11 and proteus 8. However, the project is limited for only 120 cars into a 120 capacity parking garage. The system is mainly for public and private parking where many cars up to 120 are expected to be parked where sensors are designed to detect only cars, barrier at the gate will remain opened (raised) until the counter counts 120 then it will be lowered to block further entry.

### THEORETICAL BACKGROUND

Digital systems are created to perform data processing and control tasks. Architecture tailored is what distinguishes one system from another to efficiently execute the tasks for which it was designed. Today digital technologies are dominants because digital systems are easier to design, accurate and precise, also information are stored easily and portably in digital systems. The main building blocks of automobile parking control system are the sequential devices like up/down binary counters, combinational devices like logic gates. Others include seven segment LED displays for display and sensors. The up/down counter which is a negative edge triggered is operated using S-R latch or any other 555 timer that fits.

The 120 count was achieved by decoding the three cascaded up/down counters using basic logic gates such that for every 0 through 9 counts of the first counter the second counter is enabled via its terminal count to advance through its state from 0 through 9. Similarly at terminal count of the second counter the third counter is allowed or enabled to advance through its state to count 1 which is its maximum number of counts. Once the third counter counts 1 while the second is at 2 and the first counter is at count 0 making a total of 120 counts the decoding gates becomes active and hold the counters at that 120 count. Each up count represents a detected car entering into the garage by the sensor placed at the entry likewise each down count represents a detected car leaving the garage by the sensor placed at the exit. Additional circuitries are required for these operations especially at the entry when the garage is fully occupied at 120 counts and at the exit when the garage is empty at 000 counts. In all these sections the operations are displayed using seven segment displays to show the respective counts. Finally all these sections; the counter section, sensor section, S/R latch section and display section are then connected

together to form the design of the complete system. The design was carried out and implemented using simulation softwares multisim version 11 and proteus 8. However, the project is limited for only 120 cars into a 120 parking garage, the project is mainly for public and private parking where many cars up to 120 are expected to be parked, the sensors are designed to detect only cars, the barrier at the gate will remain opened (raised) until the counter counts 120 then it will be lowered to block further entry.

**Logic Circuits/Gates**

Logic gates are digital circuits that are used to implement logic functions. A number of logic gates put together constitute a logic circuit. These digital circuits; that is the NOT), AND, OR, NAND, NOR, XOR, XNOR gates are the basic elements that form the building blocks for complex digital systems(Floyd, 2009; Karim and Chan, 2008). These basic logic gates are represented by standard distinctive symbols and perform a specific logical operation to represent a 1(HIGH voltage level) or 0 (LOW voltage level) from their inputs to their outputs in response to a given condition that can either be true (HIGH) or false (LOW) as indicated in Figure 1.

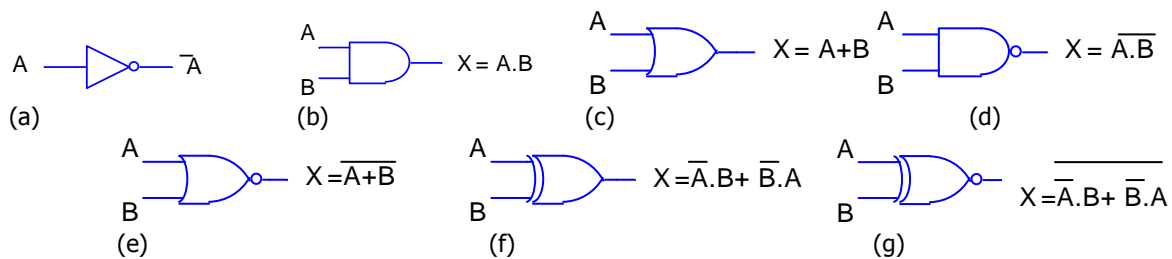

Figure 1: Logic symbols of (a) Inverter (NOT) gate, (b) AND gate, (c) OR gate, and (d) NAND gate (e) NOR Gate, (f) Exclusive OR Gate (XOR), (g) Exclusive NOR Gate (XNOR)

**LATCHES**

A latch is a type of bistable logic device (memory unit) or multivibrator whose state is determined by its excitation inputs (Floyd, 2009). It is also fundamentally known as a temporary storage device that has two stable states (SET and RESET states). Latch is basically a combinatorial circuit that has one or more of its output fed back as its input and it is classified into three types S-R Latch, Gated S-R Latch and Gated D Latch, although only Gated S-R Latch is used this research work(Karim, and Chan, 2008; Tokheim, 2006).

**Gated S-R Latch**

The gated S-R latch has same operation similar to an S-R latch. The only difference is that gated S-R latch, apart from S and R inputs also has enable input EN. When the enable input EN is LOW the latch remain inactive or remain in no change state but as long as enable input EN is HIGH the latch is controlled by S and R inputs (Floyd, 2009; Barry, 1998). The invalid state occurs when both S and R are simultaneously HIGH just like S-R latch. Figure 2 below is the logic diagram and logic symbol and Table 1 indicates the truth table of gated S-R latch.

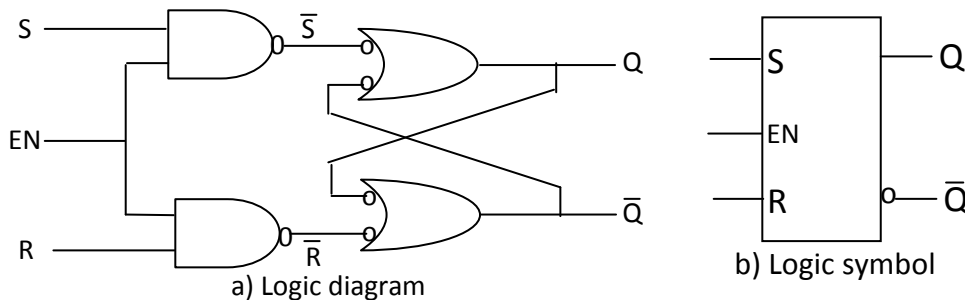

Figure 2: Gated S-R Latch.

Table 1: Truth table of gated S-R latch.

Enabling Input EN	Gated Input		Latch Input	Output			Comments
	S	R		Q			
1	0	0	1	1	NC	NC	No change condition
1	0	1	1	0	0	1	RESET condition
1	1	0	0	1	1	0	SET condition
1	1	1	0	0	1	1	Invalid condition

**UP/DOWN COUNTER**

An up/Down counter also called a bidirectional counter is a counter capable of progressing in either direction through a certain sequence. It can have any specified sequence of states. The up/down counter also come in integrated circuit(IC) form. One good example of this counter is 74HC190 type which counts in both directions. The direction of the count is determined by the level of the up/down input D/. When this input is

HIGH the counter counts down and when the input goes LOW the counter counts up. It is BCD counter (Decade) hence counts (0000) through (1001) (Floyd, 2009; Bolton, 2004). D<sub>0</sub> through D<sub>3</sub> and Q<sub>0</sub> through Q<sub>3</sub> are the data inputs and outputs respectively, also this device can be preset to any desired BCD digit using LOW level at input. Figure 3 is the 74HC190 up/down decade counter.

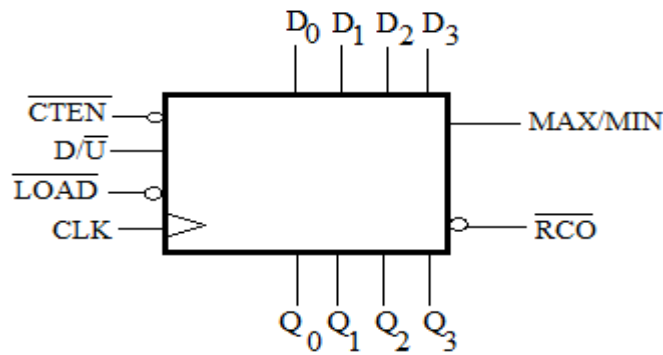

Figure 3: 74HC190 up/down decade counter

The count enable input and ripple clock output are used when cascading counters, the MAX/MIN output produces a HIGH pulse when the terminal count nine (1001) is reached in the UP mode or when the terminal count zero (0000) is reached in the DOWN mode.

**MATERIALS AND METHODS**

An automobile parking control system is one of the types of digital binary counter applications. This project

was designed using sequential circuits and combinational logic devices in conjunction with other devices ((Floyd, 2009; Barry, 1998). However, the fundamental elements used are decade up/down counters, logic gates, motor and sensors. Figure 4 shows and describes the general layout for the design of an automobile parking control system employed in this project.

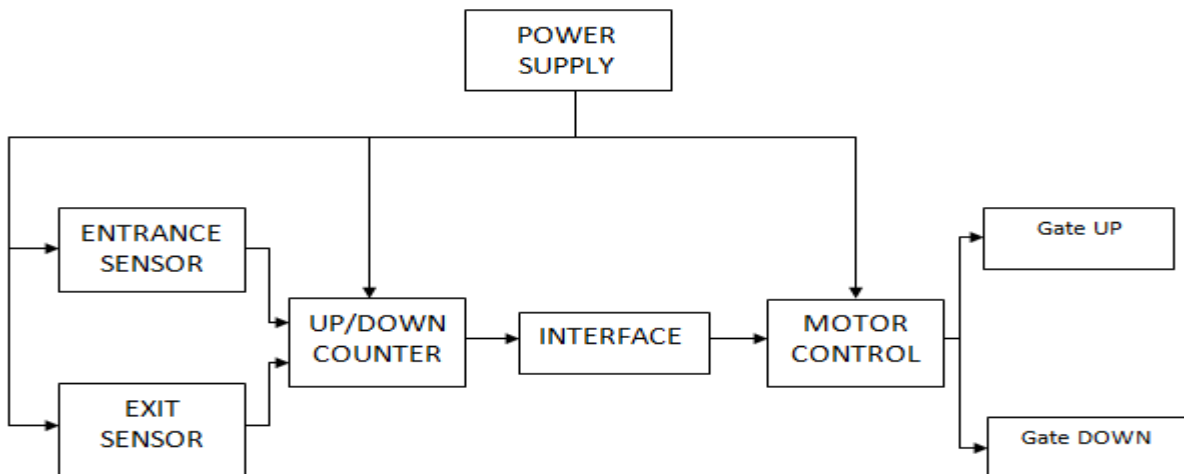

Figure 4: Block diagram of automobile parking control system.

**POWER SUPPLY UNIT**

For perfect operation of any digital device it is necessary to provide stable power supply that serve as SET when turned ON and RESET when turned OFF. The accepted technical specification for CMOS used for this design is between 2.5 V to 5 V, likewise this design employed the use of 74XX series CMOS (Kleitz, 2006; Galadanci, et al. 2013). The a.c supply is chosen to be 220/240 V, 60Hz connected to the input of the transmitter which step it down to 12V at secondary

terminal. A bridge rectifier was used for full rectification or simply conversion of a.c to d.c the capacitors were selected for good filtering of harmonics, ripples or unwanted signals. After having smooth 12V d.c the 7805 voltage stabilizer was used to stabilize the voltage at 5v as required by the design. Also a 5V d.c battery can be used for this application. Figure 5 is the circuit diagram of the power supply unit.

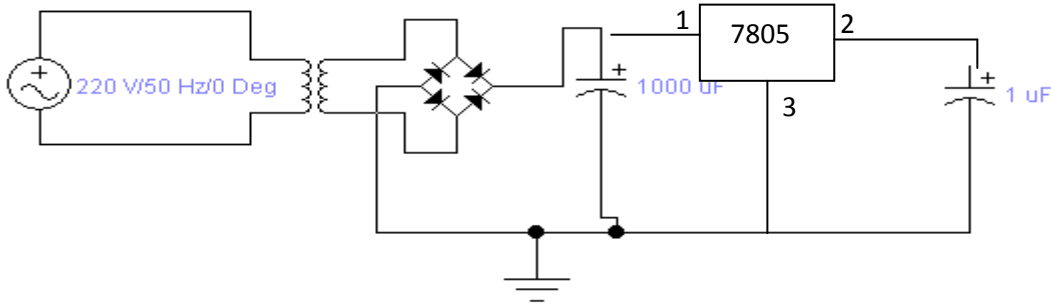

Figure 5: Circuit diagram of the power supply.

**SENSOR UNIT**

Sensors plays an important role in this design; the sensor used is phototransistor opto-coupler which is one of the types of opto electronics sensors comprise of Light emitting diode (LED) and photo transistor. This device is capable of detecting object and producing an electrical signal that is proportional to the amount of light incident on the active area of the device. As seen in Figure 6, there are two sensors placed at both the entry and the exit (Floyd, 2009; Karim and Chan, 2008; Myke, 2005). The light emitting diode (LED) at the entry IR LED1 continuously transmit an infrared signal which is directly facing the photo transistor PT1, this transistor conducts as a result of light indented on it by the LED, as such the collector of the transistor

PT1 is in LOW state. The phototransistor opto-coupler is connected in the dark activation so that when a car passes through the entry gates the infrared light is interrupted and the photo transistor PT1 stop conducting, providing a HIGH signal to the S input of the S-R latch, and hence allows the counter to advance through it state by increment its count. The operation of the Exit sensor is similar to that of entry sensor only that when a car passes through the exit sensor (IR LED2, PT2) placed at the exit gate the photo transistor stop conducting and provide HIGH signal to R input of the S-R latch which causes the counter to decrement its count (Kleitz, 2003; Scherz, 2000).

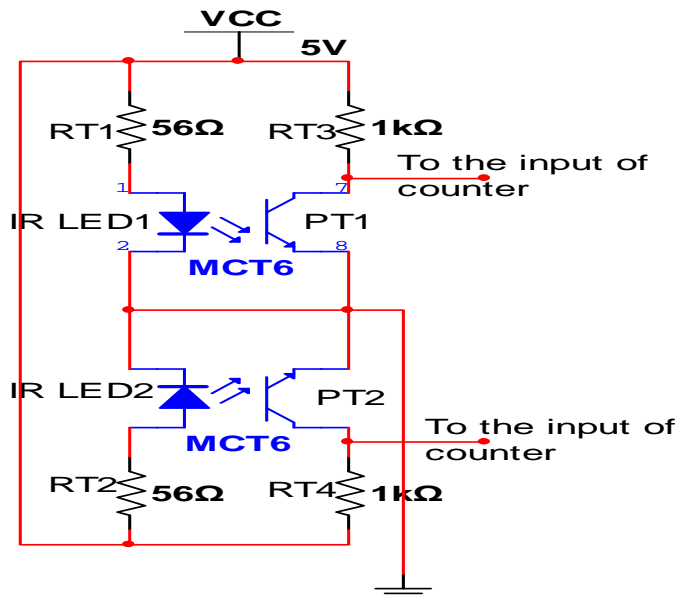

Figure 6: Sensor circuit diagram.

## COUNTER UNIT

The counting section of this project was designed by cascaded arrangement of three decade up/down counter. The 1<sup>st</sup> counter counts from 0 to 9 and then recycle to 0 for all the sequences and the 2<sup>nd</sup> counter counts from 0 to 9 and recycles to 0 through all the required sequence, similarly it also advances from 0 to 2 on the last cycle. The principle of operation of the 2<sup>nd</sup> counter is that it only advances whenever the 1<sup>st</sup> counter goes from 0 through to 9. The 3<sup>rd</sup> counter remain at count 0 until the 1<sup>st</sup> and 2<sup>nd</sup> counters count 99 simultaneously then on next clock pulse that recycles both the two counters to 00 the 3<sup>rd</sup> counter advances to 1 there by making the hundredth count (Floyd, 2009; Karim, 2008; Tokheim, 2006; Bolton, 2004). The Ripple clock output (RCO) of the 1<sup>st</sup> counter was connected to the count enable input (CTEN) of the 2<sup>nd</sup> counter and the Ripple clocking Output (RCO) of the 2<sup>nd</sup> counter was connected to the count enable input (CTEN) of the 3<sup>rd</sup> counter as shown in Figure 7. On the clock pulse that recycles the 1<sup>st</sup> counter from 0 back to 9 (as indicated on its display D1), its RCO goes LOW and hence activates the enable input CTEN of 2<sup>nd</sup> counter to show 1 on its display D2. This process continued until the maximum count is exhausted. Likewise, CTEN of the 3<sup>rd</sup> counter is enabled when RCO of the 2<sup>nd</sup> counter is LOW on its 9 to 0 transition to display count 1 from its display D3 (Galadanci *et al.*, 2013).

The S-R latch marked (0) was used because the counters are negative, that is LOW signal from S input put the counter into UP count mode while HIGH signal from R input put the counter into a DOWN count mode. That is why the negative output of the S-R latch (0) is connected to the /DOWN terminals of the counters. NOR gate G1 receives its inputs from the exit and entry sensors in such a way that when a car passes through either of the gates, the sensor placed at that gate will be active and send HIGH signal to the NOR gate in order to produce a HIGH to LOW clock pulse transition at its output which is connected to the clock inputs of all the counters.

### Mode of Operation

The exclusive NOR gate G2 shortened XNOR detect the presence of car at both the entry and exit at the same time, if that happened both the inputs of the XNOR

gate will be HIGH which consequently produces high signal to the count enable input (CTEN) of the 1<sup>st</sup> (primary) counter to deactivate the counter. Gates G3 and G4 are used to provide HIGH signal to the A and B input terminals of the 3<sup>rd</sup> and 2<sup>nd</sup> counters respectively (Floyd, 2009; Barry, 1998; Myke, 2005). When the counter is in UP count, and these gates produce LOW signal when the counters are in DOWN count the idea of gates G3 and G4 is to provide 1 and 2 at UP count and 0 at DOWN count for both the 2<sup>nd</sup> and 3<sup>rd</sup> counters respectively. The counters are decoded at 120 counts in UP sequence by taping one Q output of the 3<sup>rd</sup> counter which decodes 1. Count 2 is decoded using gates G6, G7 and G8 from the output of the 2<sup>nd</sup> counter in the same vein, in a similar manner count 0 is decoded from the first counter using four inputs NOR gate G5, such that the outputs of its terminals are connected to the four input NAND gate G11 which serve as maximum 120 count decoder (Galadanci, *et al.*, 2013). The NAND gate G11 produces a HIGH signal when one of its input goes LOW and produces LOW signal when both is inputs go HIGH this prevents the counter from advancing UP through it state more than maximum expected count. For the DOWN counter, count zero (0) is decoded using three 4-input NOR gates G10, G9 and G5 tapped from both the output of the counters. The output of these NOR gates and a wire tapped from the exit sensor provide the inputs to the 4-input NAND gate G12 which serve as the 0 decoder that prevent the counter from further counting DOWN. However, the output of these two NAND gates G11 and G12 are connected to the 2-input AND gate G13. The output of this gate is connected to the LOAD inputs of all the counters, so that when its output is HIGH the LOAD inputs of the counters becomes inactive but a LOW logic level from its output is LOW makes the LOAD input of the counters active; this loads the input data available at the inputs of the counters for the required sequence. Furthermore, the gates G14 and G15 are connected in such a way to produce a complementary operation to drive the motor UP where the barrier is attached when the parking lot is not full so as to allow many more cars into the garage or DOWN to block any further entry when the garage is fully occupied. Figure 7 indicate the circuit diagram of the counting section.

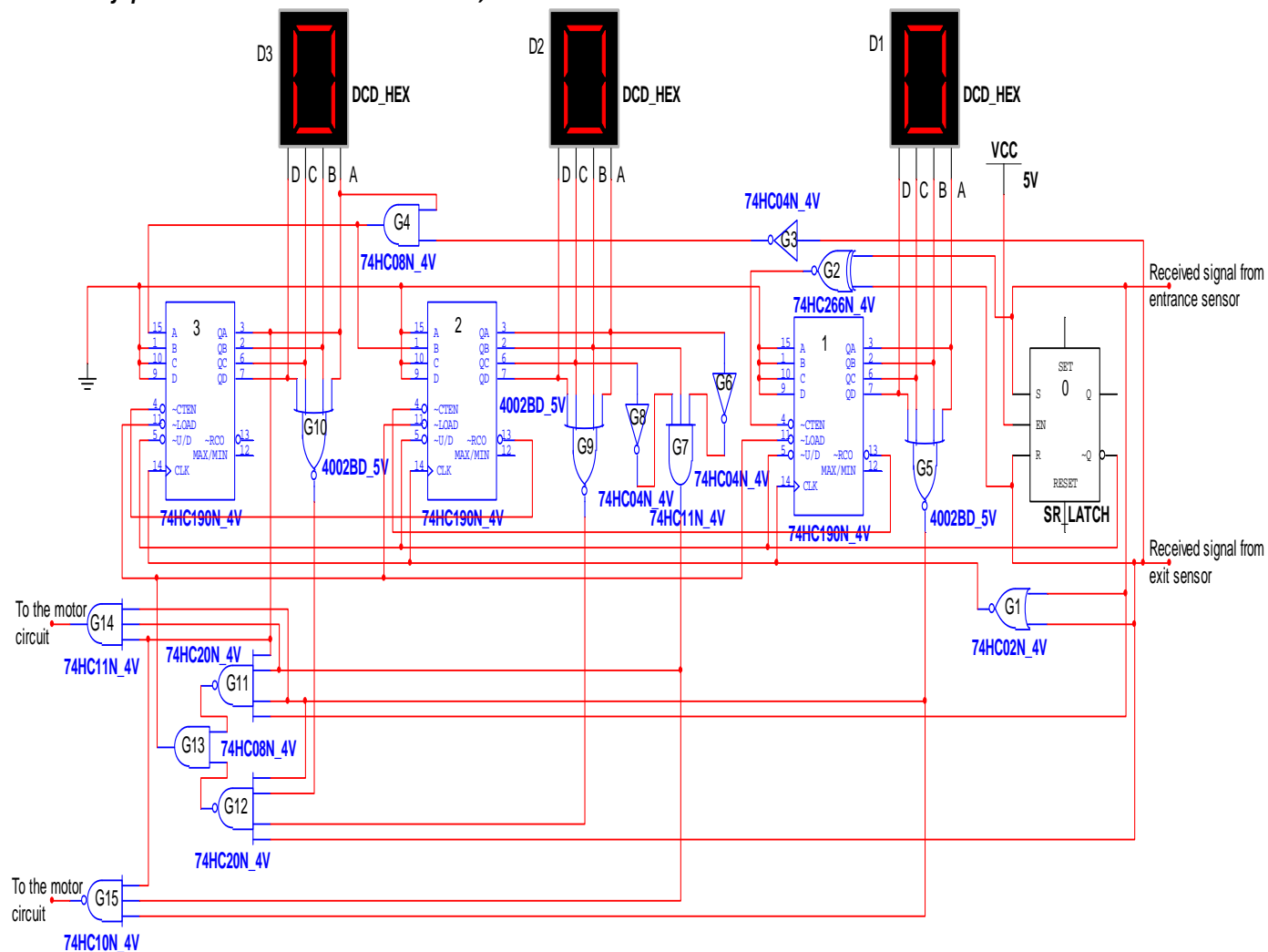

Figure 7: Counter circuit section

**MOTOR CIRCUIT SECTION**

A DC motor circuit is used to control the direction of rotation of the DC motor (M). It comprises of four cross coupled NPN and PNP transistors. The collectors of the two NPN T1 and T2 are connected to the source in order to conduct current through their emitters which are connected to the collectors of PNP transistors T3 and T4 respectively as shown in Figure 8. While the emitters of T3 and T4 are common to

ground this connection would not allow the motor to rotate. But when base terminal of T3 receive a HIGH signal, T4 receive a LOW signal through its base so that T1 and T3 transistors are active which drive the motor in anti-clockwise direction to close the gate at the maximum 120 counts. However, when the base of T4 receives HIGH signal while that of T3 receives LOW signal the transistors T2 and T4 are now active in such that they drive the motor in the clockwise direction to open the gate (Bolton, 2004; Kleiz, 2006).

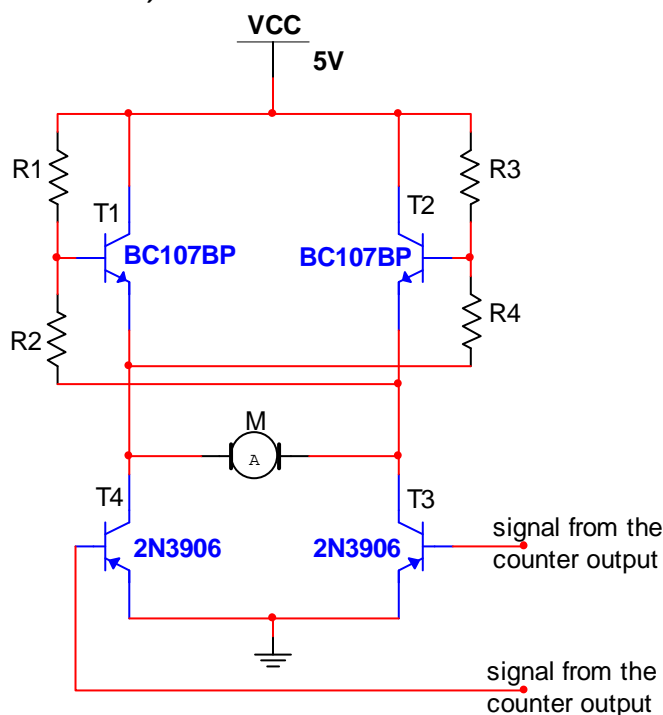

Figure 8: Motor circuit diagram.

**Component Descriptions**

The main components of the general circuit of the automobile parking control system are sensors marked MCT6, up/down decade counter numbered 1, 2 and 3,

DC motor M, logic gates and other circuitries. Table 2 shows the components and series used for this design and the number marked on each component used.

Table 2: Component used with number marked

S/N	Components	Series	Assigned number
1	S-R latch		0
2	Decade up/down counter	74HC190N	1,2 and 3
3	Seven segment display	DCD HEX RED	D1, D2 and D3
4	Not gate	74HC05N	G3, G6 and G8
5	2 input AND gate	74HC08N	G4 and G13
6	2 input NOR gate	74HC02N	G1
7	2 input XNOR gate	74HC266N	G2
8	3 input AND gate	74HC11N	G7 and G14
9	3 input NAND gate	74HC10N	G15
10	4 input NAND gate	74HC20N	G11 and G12
11	4 input NOR gate	4002BD	G5, G9 and G10
12	NPN BJT	BC107BP	T1 and T2
13	PNP BJT	2N3906	T3 and T4
14	DC MOTOR		M
15	OPTOCOUPLER	MCT6	MCT6
16	Resistors 7Ω		R1, R2, R3 and R4
17	56Ω		RT1 and RT2
18	1kΩ		RT3 and RT4

**GENERAL CIRCUIT DIAGRAM**

The general circuit is shown in Figure 9 consisting of the three units already discussed; the sensor unit, counter unit and motor circuit section. The entrance sensor MCT6 detect the presence of a car by interrupting the transmitted infrared light from photo diode (IR LLED1) to photo transistor PT1 and send a

HIGH signal to the S input of the S-R latch marked (0). The S-R latch produce a LOW signal at its output which is directly connected to the /down inputs of all the three counters and increment the counters in up count, these count continues base on the number of cars (pulses send from entrance sensor) that enter the parking lot.

The Exit sensor has the same operation as similar to that of entrance only that it detects the presence of cars leaving the garage; and sent a HIGH signal to the R input of S-R latch to produces HIGH signal through its output which causes the counter to decrement (Floyd, 2009; Karim *et al*, 2008; Tokheim, 2006; Galadanci *et al*. 2013).

**Mode of Operation of the General Circuit**

The mode of operation is based on the working principle of all the previously designed sections. As can be seen from the general circuit diagram of Figure 9 at each entry or exist of an individual vehicle the counters decrement the count until all the cars are parked in or out of the garage. The gate G1 provide a HIGH to LOW clock pulse whenever a car enters or leaves the garage having its inputs tapped from both the entry and exit sensors while its output goes to the clock input CLK of all the counters. The gate G2 allow the counter not to count up or down; that is whenever a car is entering and another car is leaving the garage at the same time, G2 force the counters to remain in their previous state. Also its inputs are tapped from both sensors at the gates and its output is linked to the count enable input CTEN of the first counter(1) which is the primary counter, meaning when the CTEN input of this counter receives a HIGH signal none of the counters will be active. The 1<sup>st</sup> counter count from 0 to 9 but at the pulse that recycles it from 9 back to 0, its ripple clock output RCO goes LOW which enables count enable of the 2<sup>nd</sup> counter. This counter advances through its state sequence at each 9 back to 0 clock pulse of the 1<sup>st</sup> counter until it reaches 9 where on the next clock pulse the ripple clock output of the 2<sup>nd</sup> counter will be LOW, activating the 3<sup>rd</sup> counter through its active LOW

count enable input CTEN to count one (1). The 1<sup>st</sup> counter has to count continuously from 0 to 9 twice to make the 3<sup>rd</sup> counter to display 1 and the 2<sup>nd</sup> counter to display 2 on the 9 to 0 clock pulse of the 1<sup>st</sup> counter. This is the maximum 120 count displayed through the seven segment displays D3, D2 and D1 respectively. At this point G3 and G4 produces HIGH logic level to the A and B inputs of 3<sup>rd</sup> and 2<sup>nd</sup> counters while LOW logic level is applied to the inputs of the 1<sup>st</sup> counter. These inputs are loaded into the counters when G13 produces a LOW signal by activating the active LOW inputs of all the counters (Roger, 1994; Barry, 1998; Galadanci, *et al*.). In the up count gate G5 decode 0 from the 1<sup>st</sup> counter and gates G6, G7 and G8 decode 2 from the 2<sup>nd</sup> counter and a wire tapped from the least significant bit (LSB) of the 3<sup>rd</sup> counter to decode 1. These are connected to the inputs of gate G11. Likewise in the down count gates G5, G9 and G10 decode 0s from all the counters and their outputs are linked to the inputs of gate G12. But if either G11 or G12 produces LOW voltage at 120 or 000 counts respectively; G13 output go LOW and hence activate the LOAD inputs of the counters which load the available data inputs on their respective input terminals. The gates G14 and G15 are complementary gates. G14 always produces a HIGH signal only at 120 counts which activate the transistors T3 and T1 to drive the DC motor to rotate in anti-clockwise direction to block further entry. These indicate that there is no more available space for parking inside the garage. Gate G15 always produces a HIGH signal when a car moves out through the exit hence activate transistors T4 and T2 to drive the motor in the clockwise direction which open the gate for further entry.



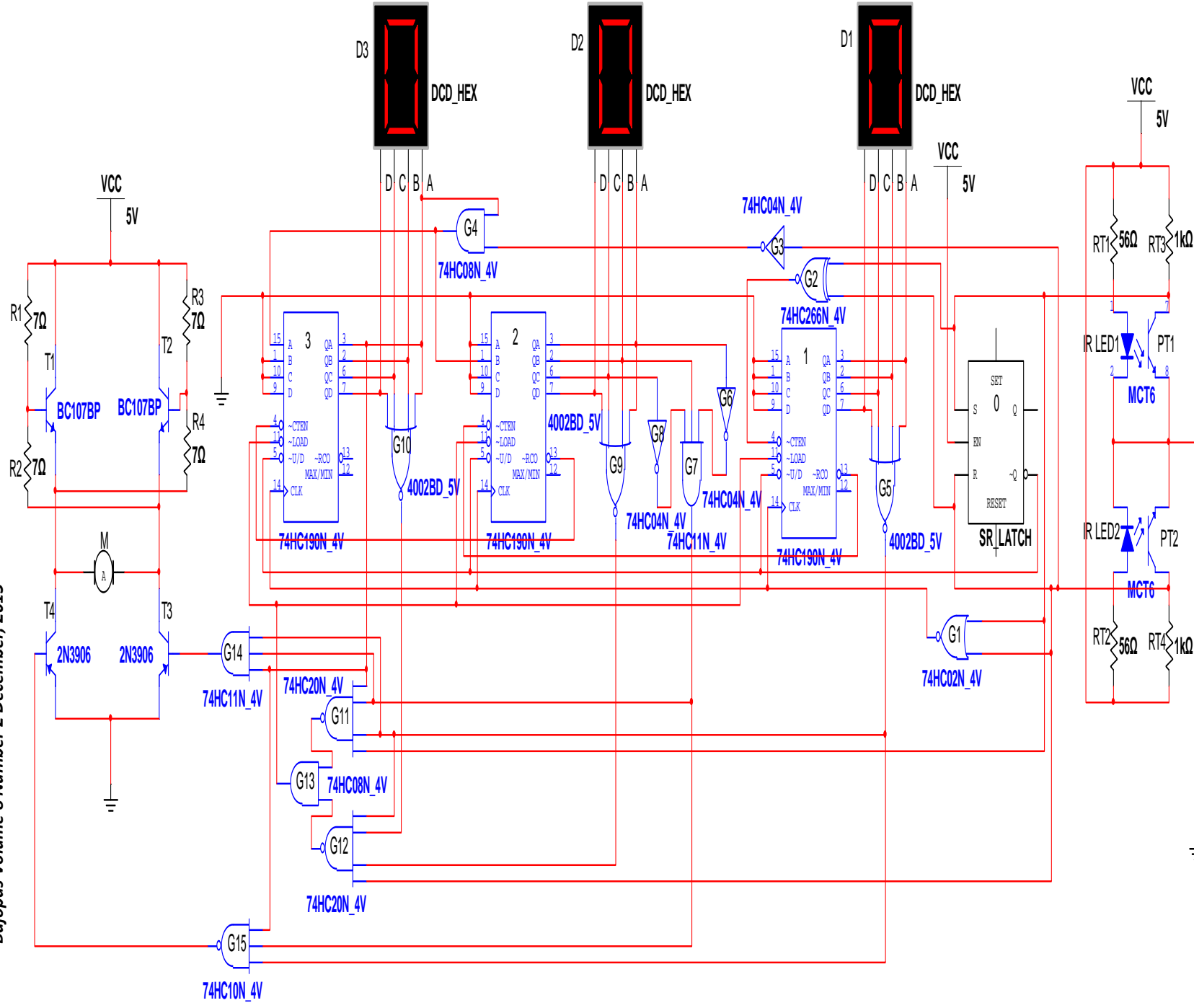

Figure 9: General circuit of a 120 capacity Automobile parking control system

**SIMULATION**

In the simulation software, sensors cannot functioned so switches are used to control the inputs. Combinational logic gates were simulated by

considering their functions using truth table for them to be properly placed where they should be. Up/down counters specifically decade were used to produce the maximum count of 120.

The 3<sup>rd</sup> counter was considered as a hundredth counter (it counts in hundred) and the 2<sup>nd</sup> counter regarded as a tenth counter while the 1<sup>st</sup> counter considered to be the unit counter. The design was simulated using national instrument electronics software (multisim version 11.0). The other part of the design that

consisted of the DC motor circuit where NPN and PNP were cross coupled to drive the motor in either direction was simulated using proteus software. Figure 10 and 11 shows pictorial diagram of both the counting part and motor circuit part respectively.

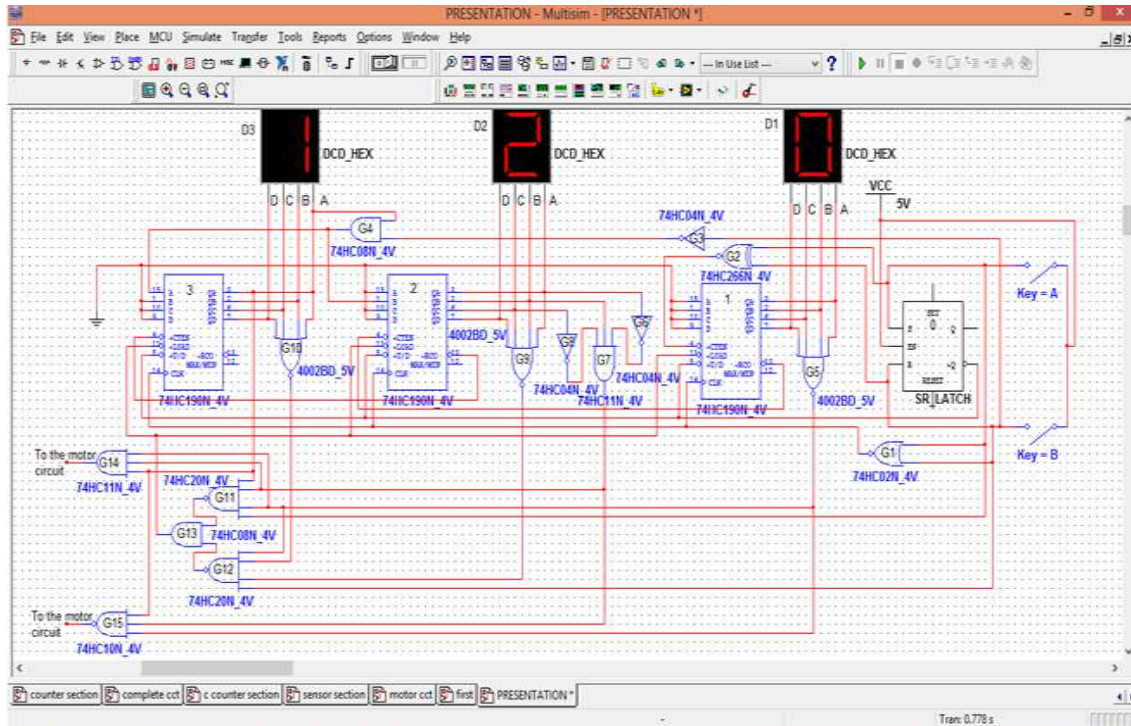

Figure 10: Simulation of counting circuit using multisim software

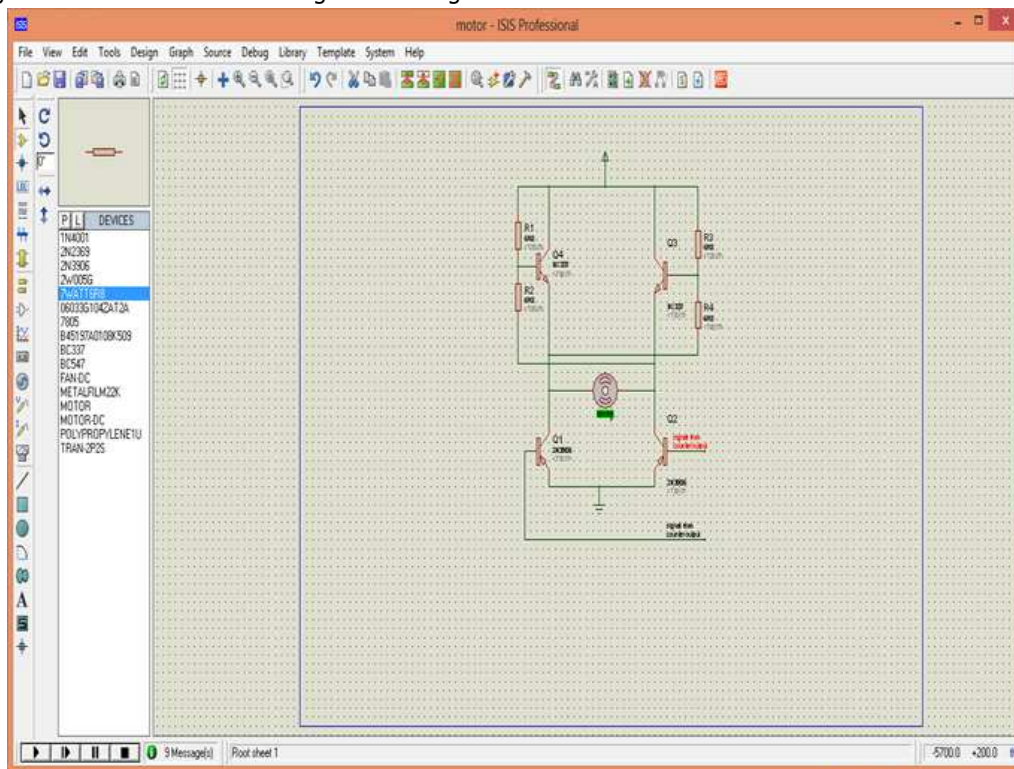

Figure 11: Simulation of motor circuit using proteus software

**RESULTS AND DISCUSSION**

The aim of this work is to design 120 capacity automatic parking lots control system where 120 cars can be parked. After the simulation was completed, the number of counts (cars entering or leaving the garage) was observed from seven segment display of each

counter. The DC motor was used to drive the gates closed or opened (anticlockwise or clockwise) when the garage is fully occupied or not. Table 3 shows the possible count display of the 1<sup>st</sup>, 2<sup>nd</sup> and 3<sup>rd</sup> counters. The 1<sup>st</sup> counter counts from 0 to 9 and recycle back to 0 for every single count of the 2<sup>nd</sup> counter.

Table 3: Display (D1) of the 1<sup>st</sup> counter for every single count of 2<sup>nd</sup> counter.

Digit Inputs	Display inputs				Display outputs						
	D	C	B	A	A	B	C	D	E	F	G
0	0	0	0	0	1	1	1	1	1	1	0
1	0	0	0	1	0	1	1	0	0	0	0
2	0	0	1	0	1	1	0	1	1	0	1
3	0	0	1	1	1	1	1	1	0	0	1
4	0	1	0	0	0	1	1	0	0	1	1
5	0	1	0	1	1	0	1	1	0	1	1
6	0	1	1	0	0	0	1	1	1	1	1
7	0	1	1	1	1	1	1	0	0	0	0
8	1	0	0	0	0	1	1	1	1	1	1
9	1	0	0	1	1	1	1	1	0	1	1
0 (Recycled)	0	0	0	0	1	1	1	1	1	1	0

But in case of the 2<sup>nd</sup> counter, it count from 0 to 9 and recycle back to 0 and also proceed to 2 as determined from its display D2 as shown in Figure 4.

Table 4: Maximum count display (D2) of the 2<sup>nd</sup> counter

Digit Inputs	Display inputs				Display outputs						
	D	C	B	A	A	B	C	D	E	F	G
0	0	0	0	0	1	1	1	1	1	1	0
1	0	0	0	1	0	1	1	0	0	0	0
2	0	0	1	0	1	1	0	1	1	0	1
3	0	0	1	1	1	1	1	1	0	0	1
4	0	1	0	0	0	1	1	0	0	1	1
5	0	1	0	1	0	0	1	1	0	1	0
6	0	1	1	0	0	0	1	1	1	1	1
7	0	1	1	1	1	1	1	0	0	0	0
8	1	0	0	0	0	1	1	1	1	1	1
9	1	0	0	1	1	1	1	1	0	1	1
0 (Recycled)	0	0	0	0	1	1	1	1	1	1	0
1	0	0	0	1	0	1	1	0	0	0	0
2	0	0	1	0	1	1	0	1	1	0	1

However, the count display of the 3<sup>rd</sup> counter is shown in Table 5, where it count 1 on the 9 to 0 clock pulse of the 2<sup>nd</sup> counter.

Table 5: Count display (D3) of the 3<sup>rd</sup> counter

Digit Inputs	Display inputs				Display outputs						
	D	C	B	A	A	B	C	D	E	F	G
0	0	0	0	0	1	1	1	1	1	1	0
1	0	0	0	1	0	1	1	0	0	0	0

**CONCLUSION**

In conclusion the design of 120 capacity automobile parking control system was successfully carried out using synchronous decade up/down counters and logic gates, sensor and DC motor. The design was implemented and simulated using proteus and multisim

simulation softwares. The result of the simulation indicates that the system functions as desired, where if the full capacities of 120 cars are parked in the parking lot, the gate closes and waits for an available space before the gates open for additional cars to enter. The available space is always determined by the number of cars that leave the garage.

**RECOMMENDATION**

This work is recommended to be carried out using programmable integrated circuit (PIC) instead of up/down counter and logic gates. It can also be designed to count up to 999 which is much easier

**REFERENCES**

- Barry, P. (1998). *Fundamentals of Digital Electronics*. National Instruments Corporation. Texas: U. S. A. Page 36-45
- Bolton, W. (2004). *Instrumentation and Control System*. Elsevier Science & Technology Books.
- Chandni, P., Monalisa S., Priya, S, and Sejal, S(2015).: Rotary Automated Car Parking System, *International Journal of Engineering Science and Innovative Technology (IJESIT)* Volume 4, Issue 2, March 2015
- loyd, T. L. (2009). *Digital Fundamentals*. Tenth edition. Pearson Prentice Hall Education International. Upper saddle River: New Jersey.
- Galadanci G.S.M., Gana S. M. and Abdullahi, M., Design and Implementation of Digital Clock using Frequency Dividers and 555 timer, *Journal of Nigerian Association of Mathematical Physics, Nigeria*, Volume 23, March 2013.
- Karim M. A. and Chan. X. (2008). *Digital design basic concept and principles*. U. S. Taylor and Francis group. U.S.A
- Kleitz, W. (2006). *Digital Electronics with VHDL*. Pearson Prentice Hall Education International.
- Upper saddle River: New Jersey. Page 541-547
- Mark, B. (2003). *Digital Design: A Comprehensive Guide to Digital Electronics and Computer System Architecture*. McGraw-Hill Companies. New York: USA.
- Myke, P. (2005). *Digital Electronics Demystified*. McGraw-Hill Companies. New York: USA.
- Pohl, J., Sethsson, M., Degerman, P., and Larsson, J.(2006) "A semi-automated parallel parking system for passenger cars", *Proc. IMechE Vol. 220 Part D: J. Automobile Engineering*, 2006, pp. 53.
- Roger L. T. (1994). *Theory and problems of digital principles 3<sup>rd</sup> Edition*, schaum's outline series. Mc Graw Hill companies. New York: USA. Page 240-244
- Scherz, P. (2000). *Practical Electronics for Inventors*. McGraw-Hill Companies. New York: USA.
- Tokheim R. L. (2006). *Digital electronics principles and applications*. Seventh edition, McGraw-Hill Companies.
- Wada, M., Yoon, K.S., Hashimoto, H. (2003): "Development of Advanced Parking Assistance System," *IEEE Transactions On Industrial Electronics*, vol. 50, pp. 4-17, February 2003.

: