

# Demand and Supply Characteristics, Supply Chain Strategy and Business Performance

Ofori Issah<sup>1</sup> | Stevenson Kenneth Mensah<sup>2\*</sup> | Dadzie Boafo Eric<sup>3</sup>

<sup>3</sup>ORCID: <https://orcid.org/0009-0001-4782-4125>

- <sup>1</sup>, Department of Supply Chain & Information System, KNUST Business School, KNUST  
<sup>2\*</sup>, Department of Supply Chain & Information System, KNUST Business School, KNUST  
<sup>3</sup>, Department of Procurement & Supply, School of Business, Takoradi Technical University

\*Correspondence: Ofori Issah, email: kwabenaofori35@gmail.com

## Abstract

*This study sought to examine the effect of demand and supply characteristics on business performance. This study adopted explanatory research design. This study adopted explanatory research design. A Purposive sampling (also known as judgment, selective or subjective sampling) sampling technique was used to obtain a total sample size of 252. A primary research instrument was used where questionnaires were adopted from literature. This study concludes that demand and supply characteristics have a positive and significant influence on supply chain strategy. Supply chain strategy has a positive and significant influence on business performance. Demand and supply characteristics have a negative but insignificant influence on business performance. Supply chain strategy positively and significantly mediates the relationship between demand and supply characteristics and business performance. The study is to help the management of organizations to develop the best strategy that will suit their demand and supply so that they can enjoy economies of scale.*

**Keywords:** Organizational Culture, E-Procurement Adoption, Procurement Performance, Value for Money

**Citation:** Ofori, I., Mensah, K., S., Dadzie. B., E., (2024), "Demand and Supply Characteristics, Supply Chain Strategy, Business Performance", African Journal of Procurement, Logistics & Supply Chain Management Society 2024, 7(9): pp. 60-98. DOI: <https://dx.doi.org/10.4314/ajplscm.v7i9.3>

---

Submitted: 01 June, 2024 | Accepted: 20 August, 2024 | Published: 23 August, 2024

---

## 1.0 INTRODUCTION

The increased uncertainties in supply chains and businesses have increased the vulnerability of the supply chain in doing and conducting business. Globalization fast-tracks the development of new technology, such that, each day, there is a new discovery (Varamäki et al., 2018; Oladimeji, Ebodaghe, & Shobayo, 2017). In the competitive business environment Supply Chain Management (SCM) has become one of the main tools for survival. Changes occur rapidly, and many entrepreneurs are left wondering whether to update or replace their old strategies (Kaplan, 2014). Globalized nature of competition combined with increasing customer demands forces firms to evaluate how they can benefit from the adoption of supply chain strategy. Supply chain resilience is another way managers in organizations can solve the problems of disruption. Supply chain resilience is the ability to withstand a supply chain shock and recover very quickly (Cabral et al., 2012). The concept of resilience focuses on aspects of science, psychology, systems

engineering, and business management. Supply chain strategy is therefore the management policy to avert these organizational shocks and turbulent. Supply chain strategy can be defined as the decisions that shape the long-term capabilities of the company's supply chain functions and their contribution to overall strategy through the ongoing reconciliation of market requirements and supply chain resources.

The complexity and demands of global business have made the reliability of supply chains uncertain; the unreliability of the supply chain is an issue that practicing managers must resolve (Macdonald & Corsi, 2013). About 83% of companies suffered supply chain disruptions in the previous 12 months, which affected the delivery of products, goods, and services (Wildgoose, Brennan, & Thompson, 2012). Unique examples included the terrorist attacks in New York in 2001, Madrid in 2004, London in 2005, and Jakarta in 2009. Natural disasters like the tsunami in 2004; Hurricane Katrina in 2005; Taiwan earthquakes in 1999, 2009, and 2010. Other disruptions are diseases like SARS in 2003, avian flu in 2005, and swine flu in 2009 (Wagner & Neshat, 2012). Although ample literature existed on disruptions in the supply chain, a concern was growing among suppliers, manufacturers, and customers as firms had become exposed to risks and weak operational performance (Hu, Gurnani, & Wang, 2013). Hsieh (2011) asserted that because demand for goods and lead times is uncertain, the smooth flow of the supply chain became distorted, leading to disruptions. Business leaders needed experienced managers to run organizations to make them sustainable because global business transactions had become complicated (Metcalfe & Benn, 2013). In most companies demand chain management (DCM) and supply chain management (SCM) are dealt with separately and one of them is usually prioritized (Hilletofth et al., 2009).

Consequently, the customer-oriented business model is not very common in reality. Instead, a demand and supply-led business model can be distinguished in most industries. Companies embracing the demand-led business model (demand chain masters) focus on DCM, and hence have strengths in managing and coordinating the demand processes Hsieh (2011). In these companies the demand-side sets the business strategy (what to sell, where to sell and how to sell) while the supply-side simply executes it by building up appropriate supply chain capabilities and advantages. These demand-led companies usually focus on activities such as identifying unique customer needs, developing innovative value propositions, managing customer relationships and/or in developing strong brands. In particular, the recent trend towards customer relationship management (CRM) has enabled many companies to capture market intelligence, to segment their customer base, to customize the value propositions and to coordinate demand chains (Varamäki et al., 2018).

Moreover, these companies use their extensive customer knowledge to apply marketing instruments in a more cost-effective way. Still, as argued by Piercy (2014), a superior demand chain strength that is not linked to supply chain strength leads to a high-cost base and slow delivery; problems which only can be compensated by an incredibly strong brand. Companies that are unable to deliver according to promises made eventually will lose credibility and customer satisfaction will decrease. Accordingly, it can be risky to focus solely, or too much, on the demand-side of the company Piercy (2015), since supply chain efficiency is also essential in creating and delivering customer value and satisfaction. Typical problems faced by demand-led companies are under-delivering and over-delivering or lost share of customer opportunities, if the company cannot capitalize on the differentiated customer needs. Companies embracing the supply-led business model (supply chain masters) focus on SCM, and hence have strength in managing and coordinating the supply processes (Martinez-Olvera and Shunk, 2016). This enables them to reduce time and costs in the supply chain, as well as to improve asset turnover. In these companies the supply-side sets the business strategy (competition based on price,

availability and/or flexibility) while the demand-side simply support it by developing appropriate product and service offerings and promoting them accurately. These supply-led companies usually focus on activities such as strategic sourcing, collaborative planning, forecasting and replenishment (CPFR) and inventory reduction. Several studies report major cost savings which companies have accomplished through their supply chain excellence, for example, Rainbird (2016) reports that an Australian supermarket chain has achieved major cost savings through its supply chain excellence, which could then be reinvested in lower selling prices. Still, as argued by Piercy (2014), a supply chain strength that is not linked to demand chain strength usually limits the company to competing on price and availability. This study therefore sought to examine the influence demand and supply characteristics on business performance.

The need for supply chain strategy is not limited to large organizations. Sharifi et al. (2013) found that most developing countries firms fail to “consider their supply chain strategy before product introduction” and “consequently experience supply chain problems that are likely to be detrimental to the firms’ growth potentials hence this study examines the influence of supply chain strategy on business performance.

Moving the decoupling point closer to the customer allows efficiency to dominate the supply chain, resulting in the capability to provide a low cost. On the other hand, positioning the decoupling point further from the end-user (closer to the main supplier), creates more capacity in the supply chain for customization. Despite the strong arguments for an integrated Demand and Supply Chain Management approach, the supply-side still seems to be disconnected from the demand-side and supply chain managers have only a faint idea of the drivers behind demand. In a study of more than 400 companies, Mentzer (2017) found that Demand Characteristics Management, as well as the concept of demand itself, is not well understood by the supply chain community. He concludes that many companies have failed to realize that supply chain coordination is not possible without an adequate understanding of demand and supply characteristics hence this study sought to examine the effect of demand and supply characteristics on business performance.

While the importance of aligning supply chain strategy with demand and supply conditions is widely recognized, there is a notable gap in research that comprehensively explores the intricate relationships between demand and supply characteristics and the specific strategic choices made within supply chain management (Chopra & Meindl, 2019). Although prior studies have individually addressed aspects of this relationship, there remains a need for a comprehensive investigation that integrates these insights into a unified framework. The limited empirical evidence and fragmented literature on the subject hinder organizations from developing well-informed and adaptable supply chain strategies. A deeper understanding of how demand and supply characteristics interact with each other to shape strategic decisions regarding inventory management, supplier selection, production planning, and distribution logistics is essential. Hence this study is to examine the influence of demand and supply characteristics on supply chain strategy.

In today's dynamic business environment, organizations face increasing challenges in effectively managing their supply chains to meet the evolving demands of customers and achieve superior business performance. The interaction between demand and supply characteristics plays a pivotal role in shaping an organization's supply chain decisions and, ultimately, its overall performance (Christopher, 2016). While previous research has explored the individual impact of demand and supply characteristics on business performance, there is a need to investigate the mediating role of supply chain strategy in this relationship. Understanding how supply chain strategy mediates the relationship between demand and supply characteristics and business

performance is crucial for organizations seeking to optimize their supply chain operations. However, there is a limited body of empirical research that addresses this specific mediating relationship. This gap in the literature leaves organizations without a comprehensive understanding of the strategic decisions they should make to enhance their supply chain's adaptability, responsiveness, and competitiveness in light of varying demand and supply conditions.

## **2.0 MATERIALS AND METHODS**

### *2.1 Demand Characteristics*

A clear and comprehensive understanding of customer demand characteristics can help design optimal supply chains to reduce unnecessary complexity (Heikkilä 2002; Walters and Rainbird 2004; Jüttner, Christopher, and Baker 2007). With the view that everything is demand-driven, some argue that supply chains should be designed from a 'customer backward' rather than 'the company outward' perspective (Aitken et al. 2005). Previous studies have identified three key characteristics of product demand, which underpin supply chain decisions. They include product volatility (Hilletoft and Eriksson 2011; Wagner, Grosse-Ruyken, and Erhun 2012), product variety (Pil and Holweg 2004; Pero et al. 2010) and product life cycle (Kaipia and Holmström 2007; Olhager 2010).

Demand uncertainty is considered by many as the main factor in supply chain design (Amin and Zhang 2013). For example, Mason-Jones, Naylor, and Towill (2000) argue that the lengths of the push and the pull segments of a supply chain depend on how certain the demand is which impact on the position of the order decoupling point or the push/pull boundary. Volatility of demand can further impact on supply chain strategies in terms of setting optimum number or strategic location of facilities, i.e., production plants, distribution centres and warehouses, to respond to the demand. ElMaraghy and Mahmoudi (2009) also claim that supply chain configuration in certain geographical locations should match demand requirements. Xiao and Qi (2008) emphasize that information sharing and good communication between multiple tiers and channels constitute a key strategy for avoiding disruption in supply chains due to demand volatility. Avolio, Bandinelli, and Rinaldi (2015) also reveal that companies in the fashion industry could leverage supply chain collaboration to cope with uncertain demand with high volatility.

### *2.1 Supply Chain Concept*

With the need to cut costs and focus on core competencies, many firms began to spin off units acquired via vertical integration and partner with other firms that provided the spun-off expertise. Consequently, the concept of supply chain management developed, as firms were attempting still to realize the cost management benefits of vertical integration while not carrying the burden of firm ownership along the supply chain? (Whipple and Frankel, 2000). Thus, as a whole, relationships with suppliers moved from adversarial to ones promoting trust (La Londe and Cooper, 1989). Relationships have advanced from competitive to collaborative (Bowersox and Closs, 1996). We have moved from short-term cost-based relationships to strategic value-added relationships (Coyle et al., 1996). There has even instituted customer satisfaction programs that ask and incorporate customer's input (Novack et al., 1995).

Since supply chain management is a set of independent firms coming together to take advantage of opportunities in the market place? (Porter, 1985), their design is by nature flexible. This flexibility enables businesses to respond to fierce global competition, short product life cycles,

and heightened customer demands (Simchi-Levi et al., 1999). The market is no longer satisfied with just the tangible product. Now customer mandates include cost effectively delivering the products to, when, where, how and in the quantity desired (Handfield and Nichols, 1999). Electronic linkages enable supply chains to efficiently coordinate operations, share information, and improve customer responsiveness (Williams, 1994a). SCM helps to improve the competitiveness of channels, which translates into improved competitiveness for all channel members. It is truly a synergistic situation, where the entire performance of the channel is improved (Cooper et al., 1997).

As previously indicated, one of the prevalent organizational issues which developed out of the traditional supply chain concept, was the focus on long-term partnerships and strategic alliances. In fact, it has been posited that firm-to-firm competition has migrated to supply chain against supply chain, necessitating supply chain integration and strategically developed supply chain networks (Watts et al., 1995). Thus, the very core of a successful supply chain, from a traditional perspective, is the development of strong inter-firm relationships among the organizations comprising the supply chain. And, the evolution of the primary organizational structure, from vertical integration to supply chain management, was accompanied by a shift in inter-firm relations, from primarily arm's length to collaborative.

#### *2.1.1 Product Characteristics and Supply Chain Strategies*

The manufacture of products with different characteristics incurs two categories of supply chain costs: production costs (Cooper, 1990) and market mediation costs (Fisher, 1997). Production costs include material, labor, manufacturing, overhead costs, and production technology investments (Randall & Ulrich, 2001). Mediation costs occur due to market variability (Randall & Ulrich, 2001). Mediation costs include inventory holding costs, product mark-down costs, and opportunity costs for not having the right products to meet the demands. Production and mediation costs can be influenced by the choice of supply chain strategy as noted by Fisher (1997) and examined in the work of Randall and Ulrich (2001). When selecting an appropriate supply chain strategy, the first step for manufacturers is to consider the characteristics of end-products, including product life cycle length, predictability of demand, product variety, and market standards for lead times and service (Fisher, 1997). Similarly, Huang, Uppal, and Shi (2002) also argue that the primary factor associated with supply chain strategy selection is the product characteristics of a particular supply chain. The literature has reached a general consensus that companies providing functional products need efficient/lean chains, while companies offering innovative products require a more responsive/agile supply chain.

Several studies have examined the relationship between supply chain strategy and product characteristics. Childerhouse et al. (2002) described the evolution of focused-demand chains over a long period of time via a case study that examines the path along which a UK lighting company developed from a traditional supply chain to an organization with four focused-demand chains. Using the DWV3 (delivery window, variability, volume, and variety) scheme, they classified the major products of the company into four clusters. For each cluster, they proposed a corresponding focused-demand chain strategy. Aitken et al. (2003) found four similar supply chain strategies that are used in different phases in the product life cycle, which can be considered as a proxy for product characteristics. Narasimhan and Kim (2002) proposed four factors that can affect supply chain strategy selection: nature of business, competitive environment, technological intensity of the product, and product and market characteristics. Their study theoretically highlighted the importance of product characteristics, but because it



focused on supply chain integration it did not examine specific supply chain strategies. Similarly, Huang et al. (2002) emphasized the relationship between product characteristics and supply chain strategy selection. They then proposed a computer program to select supply chain strategy according to the product characteristics, but the program was not tested using actual empirical data.

### *2.1. 2 Supply Chain strategies*

A supply chain strategy is defined, relative to its competitors', the set of customer needs that it seeks to satisfy through its products and services (Chopra and Meindl, 2007: 22). Strategy involves decisions relating to the selection of suppliers, the location of facilities and the choice of distribution channels. These decisions are all driven by the goal of enabling the marketing objectives of the organization to be achieved. A typical supply chain strategy should be aimed at achieving a smooth flow at minimum cost. It is now increasingly accepted that "one size does not fit all" when it comes to designing a supply chain strategy to support a wide range of products with different characteristics sold in a diversity of markets (Christopher, Peck and Towill, 2006:277). Supply chain strategies should be tailored to match the required 'order winning criteria' in the market place. Aligning the firm's operations with market place requirements has not always been extended to the wider supply chain. An organization's sourcing strategy, operations strategy and route-to-market needs to be appropriate to specific product/market condition (Christopher, 2005:117).

The fundamental changes in the environment of global competition and trends such as outsourcing require organizations to develop supply chain strategies that are aligned to "appropriate value propositions" and customer market segments. The major generic strategies in supply chain are lean and agility. Leanness means developing a value stream to eliminate all waste including time, and to enable a level schedule whereas Agility means using market knowledge and a virtual corporation to exploit profitable opportunities in a volatile marketplace (Mason-Jones, Naylor and Towill, 2000:4064).

### *2.1.3 Supply Chain Management*

Supply chain management can be defined as "the design and management of seamless, value-added process across organizational boundaries to meet the real needs of the end customer" (Fawcett et al., (2007:8). As noted by Gansler, Luby and Kornberg (2004: 8), SCM is the management and control of all materials, funds and related information in the logistics process from the acquisition of raw materials to the delivery of finished products to the end user. More so, Hugo et.al (2004:5) defines "SCM as the management philosophy aimed at integrating a network of upstream linkages (sources of supply), internal linkages inside the organization and downstream linkages (distribution and ultimate customer) in performing specific processes and activities that will ultimately create and optimize value for the customer in the form of products and services which are specifically aimed at satisfying customer demands". Generally, SCM involves relationships and managing the inflow and outflow of goods, services and information (network) between and within producers, manufacturers and the consumers (Samaranayake, 2005:48). Although the definitions of SCM differ across authors, it exists in all organizational types and can be classified into three categories: a management philosophy, implementation of a management philosophy and as a set of management processes (Klemencic, 2006:13; Lambert, 2006:13). Successful SCM requires a change from managing individual functions to integrating activities into SCM processes.

The SCM processes identified by members of The Global Supply Chain Forum are (Lambert, 2006:13): customer relation management; customer service management; demand management; order fulfillment; manufacturing flow management; supplier relationship management; product development and customization; and returns management. A supply chain includes all activities, functions and facilities (directly or indirectly) in the flow and transformation of goods and services from the material stage to the end user (Sherer, 2005:79). It is conceptualized as a network of companies from suppliers to end-users, with the intention of integrating supply and demand through coordinated company efforts. A supply chain links organizations in the upstream as well as the downstream flows of materials and information (Monczka Trent and Handfield, 2005:9). It comprises of a physical element and an information element. It is viewed as the formation of a value chain network consisting of individual functional entities committed to the controlled sharing of business data and processes. It consists of an upstream supplier network and downstream channel (Klemencic, 2006:7). Today; many organizations have become part of at least one supply chain. They have to perform equally well in order to achieve better performance. The objective of SCM is to maximize value in the supply chain. The value a supply chain generates is the differences between what the final product is worth to the customer and cost the supply chain will in-cure to fulfill the customers' request (Chopra and Meindl, 2010:22).

SCM is about competing on value, collaborating with customers and suppliers to create a position of strength in the market-place based on value derived from end consumer (Chopra and Meindl, 2007:23). Within an organization, customer value is created through collaboration and cooperation to improve efficiency (lower cost) or market effectiveness (added benefits) in ways that are most valuable to key customers. Value is not inherent in products or services, but rather is perceived or experienced by the customer (Handfield, Monczka, Giunipero and Petterson, 2009:11). The ultimate goal of a SCM process is to create customer and shareholder value, thus often called a value delivery system. SCM encompasses planning, manufacturing and operations management necessary to bring a product to the market place, from the sourcing of materials to the delivery of the completed product. Some of the issues to consider when developing or managing a supply chain include integration, information technology, collaboration, customer and supplier relationships, partnerships, outsourcing and global issues as well as social and environmental issues (Borade and Nansod, 2007:112).

Faced with a strong globalization, companies are adapting their supply chain to adequately meet the needs of customers; these needs are characterized by immediate availability. As a result, the market is dominated by uncertainty and unpredictability, as the result production, logistics, and supply chain processes are becoming more complex. According to Kamaruddin et al., the supply chain becomes difficult to manage due to the complexity inherent in dependencies exists between the parties in time and space (Kamaruddin et al., 2009). Complexity and uncertainty are the two main constraints that today's businesses must overcome to be competitive and efficient.

The integration of key business processes across the supply chain for the purpose of creating value for customers and stakeholders (Lambert, 2008). According to Christopher, an organization's supply strategy, operational strategy and orientation to the market must be adapted according to the specificity of the product / market. Fundamental changes in the environment, competition, market trends must be constantly taken into account in the Supply Chain strategy in order to exploit profitable opportunities in a volatile market (Christopher et al., 2006). (Christopher et al., 2000) adds that actors in the supply chain seek to minimize supply led times to respond swiftly to demand changes. The approach to supply chain integration was

requested by Zhao et al., who considered it a measure to which the company integrates with its supply chain partners to achieve efficient and effective information and product flows, by sharing decisions and information of high value and speed and at the lowest costs (Zhao et al., 2008). The goal of supply chain integration allows customers maximum speed, speed and at low cost while maintaining a flow of information and materials through the integration of customers and suppliers (Flynn et al., 2010).

Generally, supply chain management also involves managing relationships and managing the inflow and outflow of goods, services and information between manufacturers as well as between manufacturers and consumers. The supply chain management processes identified by (Lambert, 2008) are the processes, which concern: customer relationship management; customer service management, demand management, order fulfillment, management of the manufacturing flow, supplier relationship management, product development (Ionescu et al., 2019). Christopher bases the sustainability and prosperity of companies on the existence of an “agile supply chain” which stimulates adaptability and reactivity in the face of uncertainty and instability linked to products, markets, prices, news technologies and material availability, emphasizing the high level of customer service (Christopher, 2000).

SCM consists of four processes: plan, source, delivery and return. The planning process balances demand and delivery planning. Source transforms product to a finished state to meet planned or actual demand. Delivery is a process where goods are delivered to a customer. Return is a process of returning or receiving returned products. (Supply Chain Council, 2010) SCM synchronizes firms’ SC processes of customer relationship, order fulfillment and supplier relationship to meet customer demand and to deliver products through the SC to the customer (Ben Naylor, Naim, & Berry, 1999; L. J. Krajewski et al., 2007; Stevens, 1989).

#### *2.1.4 Business Performance*

Agency theory has developed as an adjunct to economic risk research (Holmstrom, 1979, 1987; Jensen and Meckling, 1976; Ross, 1973) in which the relationship between a principal (the owner of resources) and the agent (those who perform the work) is the focus of interest. In this respect, the principal is the shareholder while the agent is the strategic decision-making unit within the firm. Consequently, it can be claimed that, “... because executive-level managers are agents for shareholders, maximizing the present value of the firm is the appropriate motivating principle for management” (Quinn and Jones, 1995, p. 22). This view of the strategic decision-making unit as the economic agent to the shareholder is commonly referred to as the Principal –Agent Model of the Firm.

Agency theory postulates that principal-agent problems can arise from interest nonalignment and principals’ inability to monitor agents (Baker, 1992). However, this was not of direct concern in this study because: “managers/agents ... stay focused on the need for profitable operations to the extent that they own company stock and/or have part of their compensation contingent on strong financial performance (interest alignment)”; and, “... the interests of shareholders/principals are kept in mind in major corporate decisions by a vigilant board of directors (monitoring)” (Frankforter et al., 2000, p. 322). These factors play an important role in the determination of strategic orientation within the firm and commonly explain differences in the manifest strategies firms pursue in their main marketplace. For instance, where the agent exercises significant managerial discretion the autonomy created can allow the firm to pursue courses of action that satisfy their self-interest to develop a certain composition of strategic orientation (Shaw et al., 2000, p. 612).



That is, one agent may decide to emphasize particularly the traits of aggressiveness, proactiveness, and riskiness in its strategy while another may stress the defensive, analytical, and futurity elements of their strategy. Nonetheless, both of these forms of strategic orientation will be conditional upon the nature of the particular principal –agent relationship. In the context of this study, this issue is particularly salient in that high technology firms are characterized as highly innovative types of firm in product technology terms but often their strategies employed in the marketplace may differ widely. Business performance has been extolled as the ultimate dependent variable in empirical terms (Chakravarthy, 1986), advanced as a confused construct theoretically (Goodman et al., 1983), and a constant moving target in a managerial sense (Aggarwal (2001), Durand and Coeurderoy (2001). Although many business performance models are well documented with established theoretical foundations, the model that has attracted most research attention is the High Performing Systems Model (Porter, 1991).

Within this model, firms are considered high performers where their business performance is superior to that of directly comparable organizations: “superior implies that firms seek a level of ... performance that exceeds that of [their] referents, often its closest competitors” (Hunt and Morgan, 1995, p. 6). However, controversy exists in circumscribing what is meant and understood by the term business performance: “Although problems of a conceptual nature continue to underlie much of the discussion on organizational performance, its use as a key construct in strategy research studies has continued unabated. Strategic management researchers in their quest for establishing performance implications of strategic conduct of businesses continue to measure business performance using a wide array of most operationalizing schemes” (Venkatraman and Ramanujam, 1986, p. 813). The conventional approach to business performance assessment has been to emphasize profitability, frequently measured by return on investment, which is widely regarded as the ultimate “bottom line” (Reese and Cool, 1978, p. 28) test of success. However, Jacobsen (1987), among others, have heavily criticized the validity of return on investment as the sole indicator of business performance. While alternative financial indices and ratios have been used as indicants of business performance, many studies have adopted single-item measures, which can only serve as a proxy for the underlying phenomenon. Business performance is multidimensional in nature and accounting measures may be misleading because of “their (1) inadequate handling of intangibles and (2) improper valuation of sources of competitive advantage” (Bharadwaj et al., 1993, p. 87).

Contemporary knowledge suggests that accounting-based issues need to be combined with market-based assets in order to generate a more composite assessment of business performance attributes (Srivastava et al., 1998; Otley and Pollanen, 2000). Although there is an inherent likelihood that accounting- and market-based performance aims may conflict (Barwise et al., 1989), the incorporation of issues both on and off the balance sheet facilitates a more generic view of business performance (Kaplan and Norton, 1996). In consequence, there has been a recent tendency toward suggesting that financial performance is at the core of the business performance domain. Beyond this core lie operational performance measures, “such as ... market share, that define a broader conceptualization of business performance by focusing on factors that ultimately lead to financial performance” (Murphy et al., 1996, p. 16).

Many reasons account for this multidimensional interest in business performance evaluation. First, after a significant period of global downsizing in many industries, organizations are experiencing diminishing returns on increasing profits from reductions in staff numbers and

increasing operational efficiency. This has led to emerging interest on the drivers of future growth (e.g., sales) with market-based performance being seen as central to such development (Clark, 1999). Second, there has been a call from analysts and investors for more information to better understand the subtle but compelling features underlying accounting-based performance, so commonly under reported or poorly emphasized within annual reports and financial statements (Mavrincac and Siesfeld, 1997). Third, ever-improving modes of competitive behavior and innovative maneuvers by firms demand that the role of the customer in organizational decision making is moving up the boardroom agenda thus demanding a rounded articulation of business performance incorporating market-based issues (a leading research priority for the Marketing Science Institute, 2000).

## *2.2 Theoretical review*

### *2.2.1 Dynamic Capabilities Theory*

Later, Teece et al. (1997) propounded the Dynamic Capabilities theory (DCT) that also advanced the RBV. According to this theory, firms must build, develop, integrate, and reconfigure their internal and external resources and competence for adapting to dynamic environments. DCT assumes that a firm can create a position for itself in the market by creating capabilities that can help it to perform better during environmental uncertainties. As the same may not be matched by its competitors and hence can be a source of competitive advantage for the firm (Teece, 2007). A dynamic capability is defined as the capacity of a firm to create, extend, and modify its resources so as to fulfil a desired purpose (Helfat et al., 2007). The resources that are owned or controlled by a firm normally include its physical, human, and organizational assets (Eisenhardt and Martin, 2000). Dynamic capabilities are learned, and stable patterns of behaviour through which a firm systematically generates and modifies its way of doing things, so that it can become more effective (Zollo and Winter, 2002; Ambrosini et al., 2009). Supply chain flexibility can be conceptualized as a dynamic capability for several reasons including the following: it meets the criteria of being a higher-level capability (Winter, 2003); it is dedicated to the modification of operating routines (Zollo and Winter, 2002); it facilitates resource reconfiguration; and it enables sensing and capitalizing on environmental threats and opportunities (Teece, 2007). Now, as a dynamic capability can be developed through the culmination of several competences.

### *2.2.2 Resource-Based View*

The RBV has emerged as an important explanation for persistent firm-level performance differences. In contrast to theories of firm performance that focus on product-market position and the exercise of market power (e.g., Bain, 1956; Porter, 1980), the RBV maintains that firms may enjoy persistent performance advantages due to the relative superiority with which their resources address the needs of customers. Early contributions emphasized firms' ability to create and sustain competitive advantage by acquiring and defending advantageous resources positions. For instance, Wernerfelt (1984) noted that both product and resource-market scarcity might lead to persistent sources of advantage. Barney (1986) described how imperfections in the market for strategic factors may affect a firm's subsequent economic performance. Lippman and Rumelt (1982) and Rumelt (1984) described how ambiguity regarding the cause-and-effect nature of the resource development process might provide sustained sources of competitive advantage under uncertainty. Thorough reviews of the resource-based literature are provided by Mahoney and Pandian (1992) and Barney and Arikan (2001).

The RBV provides two primary conceptual insights. First, it recognizes that factor markets exist wherein firms may develop or acquire the resources necessary for product market competition. Second, the RBV points out that the resources which lead to persistent performance differentials are much broader in nature and more difficult to accumulate than the tangible assets and factors of production typically emphasized in neoclassical economic theories. For instance, the resource-based literature of ten draws upon Penroses' (1959) discussion of the administrative and entrepreneurial skills of top management teams, Nelson and Winter's (1982) notion of routines, or Itami's (1987) notion of invisible assets such as technology, customer trust, brand image, and corporate culture. Given these insights, the RBV describes how competition for resources may affect a firm's ability to implement valuable product-market strategies (Wernerfelt, 1984) and to capture economic value (Rumelt, 1984).

There are a number of assumptions underlying the RBV. The first set of assumptions state that firms are profit maximizing entities directed by boundedly rational managers (Conner, 1991; Rumelt, 1984). As a result, managers are assumed to lack the knowledge, foresight, and skill to accurately predict and plan for all the various contingencies that may arise in their search for profitable opportunities. The second set of assumptions suggest that firms must make up-front investments for the opportunity to engage in the process of creating new resources whose eventual value is inherently ambiguous and uncertain (Lippman & Rumelt, 1982). These assumptions lead to the critical concepts of resource heterogeneity and resource immobility. The idea of resource heterogeneity implies that competing firms possess different bundles of resources.

The idea of resource immobility implies that many of these resource differences may persist over time. Resource-based logic has used to generate four primary predictions regarding competitive advantage and performance (Peteraf, 1993). The first prediction describes the characteristics of resources that provide temporary sources of competitive advantage. For instance, resource-based logic suggests that firms may gain temporary competitive advantages by leveraging valuable, rare, and non-substitutable resources. Valuable resources are those that enable forms to develop and implement strategies that have the effect of increasing customers' willingness to pay or reducing a suppliers' opportunity cost (e.g., Brandenburger & Stuart, 1996). Rare resources are those for which demand exceeds supply. Non-substitutable resources are those that, either in isolation or in combination, can be uniquely used to help conceive of and implement a strategy.

Second, the RBV indicates that competitive advantage may be sustainable if there are ex-post limits to competition. In contrast to the barriers to competition highlighted in the industrial organization literature such as capacity preemption (Dixit, 1989), spatial preemption (Schmalensee, 1978), or contractual preemption (Aghion & Bolton, 1978), the RBV emphasizes how characteristics in the resource development process may inhibit the efficient imitation of critical resources. Barney and Arikan (2001) catalogue a number of rationales for resource immobility that have been developed in the RBV literature. For instance, Lippman and Rumelt (1982) indicate that the persistence of resource heterogeneity across firms is due to enforceable rights for the exclusive use of a resource or causal ambiguity regarding the application of a resource. Dierickx and Cool (1989) suggest that resources are immobile when they are subject to time compression diseconomies, are causally ambiguous, are characterized by interconnected asset stocks, or are characterized by asset mass efficiencies. Barney (1991) suggests that resources are inelastic in supply when they are path dependent, causally ambiguous, or socially complex. These notions of resource heterogeneity and resource immobility are often used as

starting assumptions for applications of the RBV framework (e.g., Barney, 1991; Wernerfelt, 1984).

The third prediction offered by the RBV describes the conditions under which economic profits may be generated. In order for a firm to enjoy an economic profit or rent, it must generate more value from its resources than expected at the time of their acquisition or development. Thus, firms which acquire or develop valuable resources in factor markets where there are ex ante limits to competition may generate temporary economic profits. Barney (1986), following Demsetz (1973), suggests two ways that markets can be imperfectly competitive. First, in the face of uncertainty, firms can be lucky and purchase or develop a resource at a cost below its true economic value. Second, it may be the case that a particular firm has unusual insights about the future value of the resources it is acquiring or developing in a strategic factor market. For example, a firm may create economic value through an acquisition strategy that creates private value above and beyond the value brought by other bidders and leverages its own valuable and costly to imitate resources (Barney, 1988). Similarly, a firm may be able to generate an economic rent in factor markets where it bids against firms who have less accurate expectations about the future value of underlying resources or economic factors (Makadok & Barney, 2001).

The fourth RBV prediction suggests that firms may generate sustained economic profits by continuously leveraging valuable, rare, and costly to imitate resources in ways their competitors cannot anticipate. This implies that ongoing economic profits are the result of a firm maintaining excess supply in critical resources which are both imperfectly mobile and generalizable. Imperfect mobility is necessary to ensure that the resource is more valuable to the focal firm than any other potential bidding firm. The resource must also be partially generalizable so that it can be extended into new applications. While the existing literature is relatively silent on the characteristics of resources that exhibit these types of characteristics, Rivkin (2001) develops a promising simulation model which suggests that such resources are of moderate complexity. One may consider Nucor's ability to repeatedly start-up steel mini-mill production sites (Ghemawat, 1992) or Cooper Industries ability to repeatedly transform old-line manufacturers (Collis & Montgomery, 1998) as representative of moderately complex resources that competitors have been unable to duplicate and have been extended into related application areas.

Although the primary predictions offered by the RBV are with regard to the relationship between investment in resources with particular characteristics and competitive advantage or performance, the framework also offers direct predictions regarding organization form. At its most basic level, RBV scholars have emphasized how resource heterogeneity may affect the implicit assumption that transaction costs are the determining factor in economic organization by arguing that organizational form is determined by firms' unique strengths and weaknesses. For instance, the RBV suggests that the ability to leverage valuable, firm-specific resources held in excess supply may lead to a marginally higher likelihood that firm-hierarchy will be optimally chosen to manage an economic exchange. Thus, a firm with a unique and valuable productive capability will be more likely to internalize those activities that are complementary to its unique features than firms' that lack this capability (e.g., Argyres, 1996; Barney, 1999; Leiblein & Miller, 2003; Quinn & Hilmer, 1994). Resource-based logic has also been used to describe the conditions under which it is optimal to coordinate specialized resources within a firm (e.g., Conner & Prahalad, 1996; Liebeskind, 1996).

This work focuses almost exclusively on the role of knowledge, particularly tacit knowledge, in explaining organizational governance choice (e.g., Grant, 1996; Kogut & Zander, 1992, 1993, 1996; Spender, 1996). For instance, the knowledge-based approach emphasizes difficulties associated with combining resources (Teece, Pisano & Shuen, 1997) and proposes that the use of a firm as opposed to joint ventures, contracts, or other organizational governance forms provides a superior mechanism for coordinating economic activities relative to other forms of organization. Firms are argued to be more efficient than other governance forms such as markets at combining and diffusing knowledge because of their superior coordinative attributes (Conner, 1991) and information processing abilities (Gulati & Singh, 1998). It is important to note that this argument is developed independent of assumptions regarding opportunistic behavior. Thus, even if parties to an exchange are presumed to act in good faith, members of one firm “may quite literally not understand what another firm wants from them” (Langlois & Foss, 1997). The general proposition is that firms exist because they are better than markets at creating, recombining, and transferring certain types of knowledge (e.g., Kogut & Zander, 1992).

### *2.3 Empirical Review*

In terms of CPFR, many studies have been conducted on average manufacturing firms in the SCM environment. In this regard, Ireland and Bruce (2016) studied a connection between CPFR characteristics and corporate performance through SCM. Additionally, Yang and Fan (2015) confirmed that average firms can increase the likelihood of supply chain stability, explaining that CPFR technology can have a positive effect on SCM performance. Competitive advantage increases sales in a crowded market consisting of multiple customers and suppliers, as the gains achieved through the introduction of CPFR and SCM impact return on investment from a financial perspective. Lieb and Randall (2017) refer to the reduction of logistics costs, the concentration of core capabilities, and increased efficiency of operations as benefits from logistics outsourcing, through an analysis of a third-party logistics service used by large American firms.

Accordingly, we can infer that the supply chain acts as a catalyst that evokes core competencies and utilizes external logistics expertise, while improving customer satisfaction to maximize business efficiency. Therefore, this SCM strategy is linked to an integrated information system to clearly plan company-wide resources, and has a very close relationship with. Performance is conceptualized as the operational success of the firm, measured mainly in terms of costs, quality, flexibility, and delivery. Mentzer et al. (2010) indicate that increased organizational competencies between firms in the supply chain, and each firm’s increased overall operational efficiency, affect performance. Moreover, firms are paying attention to various measures to accurately understand changes in performance resulting from supply chain integration. Narasimhan and Kim (2014) indicate that corporate supply chain integration has a significant effect on business performance, while Kim (2012) confirms that the level of SCM practice, competitive capability, and integration has a positive effect on performance. Moreover, other studies have confirmed that integration strategies in the supply chain have a significant effect on operational and development performance, and that financial performance is indirectly affected by these factors. Judging from these studies, SCM has an independent and positive effect on business performance; however, the operational performance also depends on operational and financial factors, and the combination of SCM and business performance is expected to have a positive effect on financial performance such as increased sales and profits.

### *2.3.2 Demand and Supply Characteristics and Business Performance*



Demand uncertainty is considered by many as the main factor in supply chain design (Amin and Zhang 2013). For example, Mason-Jones, Naylor, and Towill (2000) argue that the lengths of the push and the pull segments of a supply chain depend on how certain the demand is which impact on the position of the order decoupling point or the push/pull boundary. Volatility of demand can further impact on supply chain strategies in terms of setting optimum number or strategic location of facilities, i.e., production plants, distribution centres and warehouses, to respond to the demand. ElMaraghy and Mahmoudi (2009) also claim that supply chain configuration in certain geographical locations should match demand requirements. Xiao and Qi (2008) emphasize that information sharing and good communication between multiple tiers and channels constitute a key strategy for avoiding disruption in supply chains due to demand volatility.

D'Avolio, Bandinelli and Rinaldi (2015) also reveal that companies in the fashion industry could leverage supply chain collaboration to cope with uncertain demand with high volatility. Product variety is another driver of supply chain complexity as an optimal supply chain design for one type of product may not be optimal for another. For example, a large volume of low-value products requires an efficient supply chain design to achieve economies of scale. In contrast, small volume of high-value products may require a responsive supply chain to provide flexibility to meet customer needs. As such, one-size-fits all design is inadequate and a hybrid or parallel design would be necessary when the product variety increases. Brun and Pero (2012) state that supply chain choices should be aligned to product variety and higher supply chain coordination is needed when there is high product variety (Arshinder, Kanda, and Deshmukh 2008). Based on the arguments, it is proposed that:

*H1: Demand Characteristics has a positive influence on Business Performance*

*H2: Supply Characteristics has a positive influence on Business Performance*

### *2.3 3 Demand and supply characteristics and Supply Chain strategy*

A clear and comprehensive understanding of customer demand characteristics can help design optimal supply chains to reduce unnecessary complexity (Heikkilä 2002; Walters and Rainbird 2004; Jüttner, Christopher, and Baker 2007). With the view that everything is demand-driven, some argue that supply chains should be designed from a 'customer backward' rather than 'the company outward' perspective (Aitken et al. 2005). Previous studies have identified three key characteristics of product demand, which underpin supply chain decisions. They include product volatility (Hille and Eriksson, 2011; Wagner, Grosse-Ruyken, and Erhun 2012), product variety (Pil and Holweg 2004; Pero et al., 2010) and product life cycle (Kaipia and Holmström 2007; Olhager, 2010). The implications of demand volatility or uncertainty on supply chain choices are long debated in the extant literature, both in terms of supply chain strategy and supply chain design. From a perspective of supply chain strategy, Fisher (1997) states that products based on their demand characteristics fit into two main categories: 'functional' and 'innovative'. Functional products need an efficient supply chain where the main objective of operational management is to reduce supply chain costs. On the other hand, innovative products require responsive supply chains that focus on flexibility and reduce lead time to fulfil customer demand. In line with Fisher (1997), Lee (2002) divides products into functional and innovative types based on demand uncertainty (low/ high) and separates supply into stable and evolving types based on supply chain uncertainty (low/high). To deal with different levels of demand and supply chain uncertainties, three key supply chain strategies are proposed: 'efficient', 'risk

hedging', 'responsive', or 'agile'. Heikkilä (2002) argues that Fisher's (1997) structuring of the supply chains based on demand characteristics is overly simplistic. Separating the products into two categories is not feasible and seems to be problematic as many companies consider their products to be hybrid types (Lo and Power 2010). The arguments made by the scholars above suggest that

*H3: Demand characteristics has a positive influence on Supply Chain strategy.*

*H4: supply characteristics has a positive influence on Supply Chain strategy*

#### *2.3.4 Supply Chain Strategy and Business Performance*

It is difficult to achieve a competitive advantage through internal development alone in an organization. With environmental changes and global competition intensifying, firms need to find ways to develop new competencies to adapt and maintain their competitiveness. Hong and Jeong (2021) imply that corporate supply chain strategies are key mechanisms that boost innovation and performance, suggesting that these can help firms adapt to environmental changes and aid their growth. Thus, an SCM strategy can help firms cope with these challenges. The strategy of demand and supply planning, as suggested by Saleheen et al. (2017) has been applied in various areas in organizational relationships in the supply chain and is a relevant component of VMI, ERP, CPFR, WMS, and outsourcing strategies, facilitating factors that improve corporate performance. In terms of VMI, a strong flow of information across inter-firm relationships can establish a mutually agreed inventory level. In terms of ERP, a comprehensive resource management system can be a next-generation business system as well as a set of applications that enable internal corporate business functions to be properly displayed in harmony.

*H5: Therefore, this study proposes that supply chain strategy has a positive influence on business performance*

#### *2.3.5 The mediating effect of Supply Chain Strategy on the relationship between Demand and Supply characteristics and Business Performance*

Supply chain is one approach that can be used to solve the problem of consumer needs to the product. The supply chain includes not only manufacturing and suppliers, but also transportation, warehousing, retailing, and consumers themselves. The main purpose of the supply chain is to satisfy the needs of the customer so that the company gets a profit. The activity of the supply chain begins with consumer demand and ends when the customer or customer has been satisfied (Bowershox, 2000; Pujawan, 2005; Chopra and Meindl, 2007). Moreover, supply chain management is a set of approaches applied to efficiently integrate suppliers, entrepreneurs, warehouses, and other storage areas so that products can be distributed with the right quantity, place and time so as to minimize costs and satisfy customers. Supply chain management is the integration of procurement activities of materials and services, conversion into intermediate and final products, and delivery to customers that include purchasing and outsourcing activities, plus other functions essential to the relationship between supplier and distributor (Heizer and Render, 2010).

Supply chain management aims to make the entire system efficient and effective, minimizing costs from transportation and distribution to raw material inventories, in-process materials and finished goods. Some of the major players who have an interest in supply chain management are manufacturing suppliers, distributors, retailers, and consumers (David et.al. in Indrajit and Djokopranoto, 2006). Supply chain management as an approach to unite suppliers,

manufacturing, warehouses, and other storage places efficiently so that the product can be produced and distributed with the right amount, right location and the right time to reduce costs and meet customer needs (Simichi-Levi et al., 2000). According to Aramyam et al. (2006), the development of a supply chain performance measurement system needs to take into consideration the specific characteristics of the supply chain to be measured. Furthermore, Lau et al. (2002) stated partnerships among members in the supply chain were carried out to ensure product quality and supply chain effectiveness, which in turn will achieve optimal results. Demirbag et al. (2006) confirmed that optimal company performance can be seen from its operational performance. Operational performance is needed when a company wants to meet customer satisfaction, emphasizing the internal business processes, and activities that are directed to improve innovation in the organization. Therefore, operational performance measurement is very important for an organization, in order to achieve both efficiency and optimal business performance.

The links between SCSs and corporate financial performance are increasing (Martin and Patterson, 2009). SCSs are complex and strategically important in creating and maintaining firms' competitive advantage (Gibilaro and Mattarocci, 2019; Ellinger and Ellinger, 2014). Robust supply chain design creates a major source of competitive advantage for companies (Okongwu et al., 2015) and SCSs affect financial performance positively (Greer and Theuri, 2012). Corporations have realised the importance of SCSs and appreciate the distinctive competitive advantages that a well-managed supply chain brings (Stevens and Johnson, 2016). SCSs assist in creating or destroying shareholder value due to its influence on financial results (Ellinger et al., 2011). Managers need to identify the SCSs that create the most value for investors (Losbichler et al., 2008). Recently, supply chain management has attracted considerable investment (Ellinger and Ellinger, 2014) and managers must justify and demonstrate how such investment boosts financial performance (Shi and Yu, 2013). This need for innovation is compelling executives to recognise, review and adopt SCSs strategies that drive corporate operational and financial performance (Zubairu et al., 2018). Based on the scholars' arguments, it is proposed that:

*H6: Supply Chain Strategy positively mediates on the relationship between Demand characteristics and Business Performance*

*H7: Supply Chain Strategy positively mediates on the relationship between Demand and Supply characteristics and Business Performance*

## 2.4 Conceptual Framework

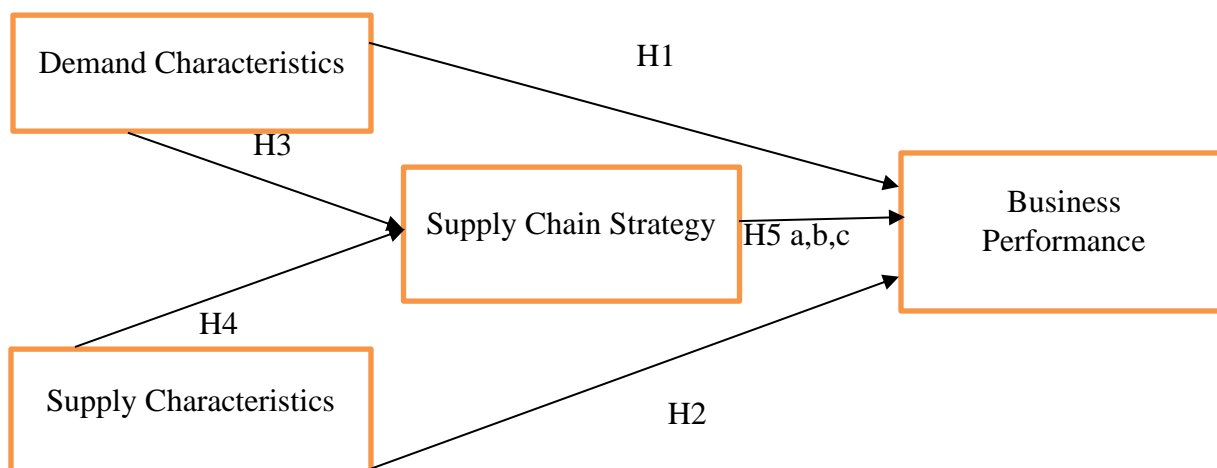

### **3.0 METHODOLOGY**

#### *3.1 Research Design*

According to Bless and Higson-Smith (2004), research design is a set of processes that leads a researcher in the process of validating a specific assumption not including other potential explanation. It is the map or strategy which guides the researcher to find answers to the research questions. A research design can be regarded as an arrangement of conditions for collection and analysis of data in a manner that aims to combine relevancy with the research purpose. It will be the conceptual structure within which research is conducted. A research design is defined as the scheme, outline or plan that is used to generate answers to the research problems (Orodho, 2000). According to Kothari (2003), a research design constitutes to the blueprint for collection, measurement and analysis of data. Research design refers to the method used to carry out the research (Kothari, 2003).

This study adopted explanatory research design because of the inferential statistics of ascertaining the causal relationship of the dependent and independent variables. Research design defines the approach and style used by the researcher in carrying out a study. Usually, a research design is chosen based on the objectives of the study (Polit & Beck, 2004). As indicated by De Vaus (2001), research design is the general plans and techniques used by a researcher in undertaking a study. Kothari (2004) further added that, a research design is the conceptual structure within which research is conducted. In other words, it can be described as a master plan which indicates the strategies for conducting research. According to Kumar (2008), research design involves all the techniques used to conduct a research operation. Quantitative or qualitative and sometimes a mixture of both are the research design styles mostly used by researchers. The quantitative method was employed by the researcher through a survey questionnaire to determine the effect of demand and supply chain characteristics and business performance, the mediating role of supply chain strategy.

#### *3.1 Research Approach*

Quantitative research method design was used because the research hypotheses are best answered by quantitative data. The researcher collected primary data by use of questionnaires to compare results of the questionnaire information. Results from quantitative research method were used to enhance, elaborate or clarify results. Questions of frequency may best be explored by quantitative methods. This quantitative method provides a stronger understanding of the problem or question than other. The quantitative approach allows the researcher to collect information from the people on their habits, opinions, attitudes and any other educational or social issues (Namusonge, 2010). Creswell (2014) showed that quantitative form of data provides different kind of information. Quantitative data collection has both limitations and strengths that can be combined to develop a stronger understanding of the research problem or questions (and, as well, overcome the limitations of each).

#### *3.2 Target Population*

The Target population for this study included selected manufacturing and extractive firms in Ashanti Region of Ghana. There are a lot of manufacturing and extractive firms in Ghana but due to the time constraints some of the industries were selected for the study and a census study were conducted on the selected industries. Most of the manufacturing firms in Ghana are

considered as a both labour and capital-intensive sector with over 10,584 permanent and temporary people employed in the industries (Bureau of Labor Statistics Ghana, 2017).

The manufacturing firms were considered to find out how supply chain strategy moderating can be used to enhance business performance by balancing demand and supply characteristics across these industries. According to Igwenagu (2016), a sampling frame is the population units which the sample units are evident. The units are referred to as sampling units. Sample can be defined as a subset of population. The number of elements in a sample is called the sample size. Strydom and Venter (2002) define a population as the sampling frame; the totality of person; event organization unit; case records or other sampling units with which the research problem is concerned.

### *3.3 Sampling Technique and Sample size*

Purposive sampling (also known as judgment, selective or subjective sampling) is a sampling technique in which researcher relies on his or her own judgment when choosing members of population to participate in the study and is a form of non-probability sampling technique. The main goal of purposive sampling is to focus on particular characteristics of a population that are of interest, which will best enable you to answer your research questions. Rather, it is a choice, the purpose of which varies depending on the type of sampling technique that is used. The goal of purposive sampling is not to randomly select units from a population to create a sample with the intention of making generalizations (i.e., statistical inferences) from that sample to the population of interest. This is the general intent of research that is guided by a quantitative research design. Purposeful sampling is a technique widely used in quantitative research for the identification and selection of information-rich cases for the most effective use of limited resources (Patton, 2002). This involves identifying and selecting individuals or groups of individuals that are especially knowledgeable about or experienced with a phenomenon of interest (Cresswell & Plano Clark, 2011).

In addition to knowledge and experience, Bernard (2002) noted the importance of availability and willingness to participate, and the ability to communicate experiences and opinions in an articulate, expressive, and reflective manner. Supply chain strategy and its application is relevant at this level prompting Purposive sampling (also known as judgment, selective or subjective sampling) is a sampling technique in which researcher relies on his or her own judgment when choosing members of population to participate in the study and is a form of non-probability sampling technique. The main goal of purposive sampling is to focus on particular characteristics of a population that are of interest, which will best enable you to answer your research questions. Rather, it is a choice, the purpose of which varies depending on the type of sampling technique that is used. The goal of purposive sampling is not to randomly select units from a population to create a sample with the intention of making generalizations (i.e., statistical inferences) from that sample to the population of interest. This is the general intent of research that is guided by a quantitative research design.

Purposeful sampling is a technique widely used in quantitative research for the identification and selection of information-rich cases for the most effective use of limited resources (Patton, 2002). This involves identifying and selecting individuals or groups of individuals that are especially knowledgeable about or experienced with a phenomenon of interest (Cresswell & Plano Clark, 2011). In addition to knowledge and experience, Bernard (2002) noted the importance of availability and willingness to participate, and the ability to communicate experiences and opinions in an articulate, expressive, and reflective manner. Questionnaires were distributed to



individual heads of the various supply chain departments in the selected industries systematically until the required number was achieved.

### *3.4 Sample size*

Purposive sampling (also known as judgment, selective or subjective sampling) is a sampling technique in which researcher relies on his or her own judgment when choosing members of population to participate in the study and is a form of non-probability sampling technique. The main goal of purposive sampling is to focus on particular characteristics of a population that are of interest, which will best enable you to answer your research questions. Rather, it is a choice, the purpose of which varies depending on the type of sampling technique that is used. The goal of purposive sampling is not to randomly select units from a population to create a sample with the intention of making generalizations (i.e., statistical inferences) from that sample to the population of interest. This is the general intent of research that is guided by a quantitative research design.

Purposeful sampling is a technique widely used in quantitative research for the identification and selection of information-rich cases for the most effective use of limited resources ([Patton, 2002](#)). This involves identifying and selecting individuals or groups of individuals that are especially knowledgeable about or experienced with a phenomenon of interest ([Cresswell & Plano Clark, 2011](#)). In addition to knowledge and experience, [Bernard \(2002\)](#) noted the importance of availability and willingness to participate, and the ability to communicate experiences and opinions in an articulate, expressive, and reflective manner. This study administered three hundred (300) questionnaires to the managers of the selected manufacturing firms in Ashanti region of Ghana of which two hundred and fifty-two (252) participants answered the questionnaire correctly. Therefore, the total sample size for this study is 252.

### *3.5 Data collection methods*

This is a process of gathering and measuring information on targeted variables in an established systematic fashion, which then enables one to answer relevant questions and evaluate outcomes. The goal for all data collection is to capture quality evidence that allows analysis to lead to the formulation of convincing and credible answers to the questions that were posed, ([Lescroël et al., 2014](#)). This study makes use of only primary data source. The primary data were gathered through a self-administered questionnaire. This instrument was designed with reference to measures adopted by some authors in measuring similar constructs in their studies. The questionnaire was closed ended questions. In order to ensure that respondent clearly provide answers and enable researcher code responses with ease, items on the questionnaire were grouped under various themes in an accordance of the research objectives.

### *3.6 Data collection procedure*

The study adopted only one approach in collecting responses in the actual field of the study. The researcher used only quantitative data collection methods for the study. Data Collection is an important aspect of any type of research study as inaccurate data collection can impact the results of a study and ultimately lead to invalid results. The study adopted a Likert scale, five-point rating scale of 1,2,3,4, and 5 which were used to capture responses in the questionnaire. The format of a typical five level Likert item: 1) Strongly disagree, 2) Disagree, 3) Neutral, 4) Agree 5) Strongly Agree.

#### 4.0 RESULTS AND DISCUSSIONS

The table 4.1 presents the results on the respondents' backgrounds of the study and the issues taken into consideration were the respondents' gender, age, educational background and respondents' years of experience. The gender representation of the respondents, 159 of the respondents was male representing 63.1% whereas 93 of the respondents were female representing 36.9%. Concerning the respondents age, 19 were between the age of 25-30 years representing 7.5%, 54 were between the age of 31-35 years representing 21.4%, 37 were between the age of 36-40 years representing 14.7%, 54 were between the age of 41-45 years representing 21.4%, 21 were between the age of 46-50 years representing 8.3%, 22 were between the age of 51-55 years representing 8.7% and 45 were between the age of 56-60 years representing 17.9%. Their Level of education, 94 of the respondents were Higher National Diploma and other equivalent diploma graduate representing 37.3%, 88 of the respondents were first degree graduate representing 34.9%, 40 of the respondents were second degree graduate representing 15.9% and 30 of the respondents were doctorate graduate representing 11.9%. Concerning their years of working experience, 20 of the respondents have worked for about 3-5 years representing 7.9%, 47 of the respondents have worked for about 6-10 years representing 18.7%, 54 of the respondents have worked for about 11-15 years representing 21.4%, 68 of the respondents have worked for about 16-20 years representing 27.0% and 63 of the respondents have worked for about 21 -25 years representing 25.0%.

*Table 4.1 Respondents Demographics*

Profile	Characteristics	Frequency	Percentage
Gender	Male	159	63.1
	Female	93	36.9
Total		252	100
Age	25-30 years	19	7.5
	31-35 years	54	21.4
	36-40 years	37	14.7
	41-45 years	54	21.4
	46-50 years	21	8.3
	51-55 years	22	8.7
	56-60 years	45	17.9
Total		252	100
Level of education	HND/Diploma	94	37.3
	First degree	88	34.9
	Second degree	40	15.9
	Doctorate	30	11.9
Total		252	100
Years of working experience	3-5 years	20	7.9
	6-10 years	47	18.7
	11-15 years	54	21.4
	16-20 years	68	27.0
	21 -25 years	63	25.0
Total		252	100

#### 4.2 Validity and Reliability Test

Validity refers to the extent to which a measure or set of measures correctly represent the constructs of the study (Bhattacharjee, 2012). Reliability is an assessment of degree of consistency between multiple measurements of the same variable. It is therefore concerned with whether alternative measurements at different times would reveal similar information. Variables differ in how well they could be measured-i.e. how much measurable information their measurement scale is able to provide.

There is some measurement error involved in every measurement, which determines the amount of information that can be obtained (Bhattacharjee, 2012). Reliability refers to the consistency and stability of a score from measurement scale as to whether the results in the survey could be duplicated in similar surveys (Bhattacharjee, 2012). Reliability is said to be particularly important when latent variables are calculated from underlying item scales. Since these scales consist of a group of interrelated items designed to measure underlying constructs, it is important to establish whether the same set of items would extract the same responses if they were re-administered to the same sample group on more than one occasion. Variables derived from test instruments are only said to be reliable when it is clear that they elicit stable responses over multiple measurements of the instruments surveys (Bhattacharjee, 2012).

Cronbrash's Alpha coefficient was used as a measure of internal consistency-reliability of the scale used in this study. Cronbach's Alpha is a measure of internal reliability for multi-item summated rating scales. Its values range 0 and 1, where the higher the score, the more reliable the scale. A coefficient reliability of 0.70 or higher indicated that the instrument used is reliable (Cronbach, 2004).

Also, in order to analyze the data in relation to ascertain the validity threshold, the measurement of the response using Kaiser Mayer Olkin test to be certain that the data is acceptable to proceed to the inferential statistics to make fair and valid conclusions. Kaiser (1974) proposes that values above 0.5 are acceptable and appropriate. In a situation that the value is less than 0.5, then there is a need to collect additional data or reconsider which variable is to take into consideration. The table 4.2 presents the results on the reliability and the validity of the constructs.

*Table 4.2 Reliability and Validity Results*

Variable	Loadings	KMO	Variance (%)	Cronbach's Alpha
Business performance	.717	.876	51.675	.905
	.783			
	.542			
	.830			
	.555			
	.524			
	.656			
	.720			
	.748			
	.738			
	.778			

Supply chain strategy	.777	.892	53.870	.941
	.708			
	.644			
	.647			
	.787			
	.780			
	.834			
	.706			
	.638			
	.788			
	.551			
	.689			
	.733			
	.642			
	.575			
	.572			
Demand and supply characteristics	.687	.877	48.189	.872
	.703			
	.775			
	.795			
	.770			
	.672			
	.819			
	.694			
	.713			
	.713			
	.576			
	.627			
	.691			
	.618			

The construct validity was tested by using exploratory factor analysis (EFA). The purpose of applying EFA is to isolate the dimensions of each construct. The factors were extracted by applying principal component analysis individually on green logistics, food distribution, post-harvest losses and facility location with varimax rotation. The factor loading of at least 0.30 is considered acceptable variable (Nunnally, 1978). In order to ensure quality of extracted factors, a factor loading of at least 0.50 was considered acceptable. Hoang et al. (2006) proposed that factor loading of .07 is highly recommended therefore during the validation process, items with factor loading less than 0.7 were subsequently removed (Hoang et al., 2006). All reliability values are above 0.5 which shows that all the steps in this study are valid and reliable. The internal consistency analysis was carried out to check the reliability of the survey data.

The Cronbach's Alpha is the basic measure of the reliability which indicates relative reliability of each factor as a scale. The sufficient value of Cronbach's Alpha is 0.6 (Nunnally, 1967). In order to improve the reliability, items with values less than 0.6 were eliminated (Rahman, 2001). All of

the reliability coefficient values in this study are above 0.7 which show that each factor is sufficiently reliable measure. The suitability of the sample was tested by applying KMO measure. The KMO values are also generally acceptable because Kaiser (1974) proposes that values above 0.5 are acceptable. Moreover, covariance between each pair of independent variables is found to be at supportive if they do not exceed 0.90 and thus are acceptable for discriminant validity (Hair et al., 1998).

#### 4.3 Construct Validity

According to Furr & Bacharach (2003) construct validity refers to an extent to which the measurement score reflects latent construct to be measured. Meanwhile, Hair et al. (2019) define construct validity as an approach to make sure that a set of variables represents the theoretical latent construct which is being measured. Fornell & Larcker (1998); Agarwal (2013) noted that construct validity of confirmatory factor analysis includes two main tests, namely convergent validity test and discriminant validity test. Campbell & Fiske (1959) describe that convergent and discriminant validity are essential requirements on every instrument development to obtain accountable data psychometrically. Accordingly, this research reported both convergent and discriminant validity.

*Table 4.3 Convergent and discriminant validity*

<b>Variable</b>	<b>AVE</b>	<b>Discriminant Validity</b>	<b>Composite Reliability</b>
Business Performance	0.578	0.760	0.847
Supply Chain Strategy	0.566	0.752	0.869
Demand and Supply Characteristics	0.572	0.757	0.843

Igbaria et al. (1997) demonstrated that a variable is of good fit if the latent variable shows the factor loading of > 0.50. Haire et al. (2019) recommended that an Average Variance Extracted (AVE) as convergent validity measure since AVE could explain the degree to which items are shared between the construct in Structural Equation Modeling (SEM) where AVE 0.5 or more are acceptable as convergent validity. The scale development in this study involved three construct namely Supply and Demand characteristics, supply Chain Strategy and Business Performance. The results indicated that the AVE values for the three constructs respectively were 0.578; 0.566 and 0.572. As all the constructs were within and above the threshold of > 0.50, it is concluded that they could measure the latent variables. Hence, they fulfilled the convergent validity criteria. Haire et al. (2019) stated that discriminant validity could be established by correlating one construct to another. If the correlation value of both constructs is lower than 0.85, it means that the discriminant validity exists. Besides, Furnell and Larker (1981) argue that discriminant validity exists if latent variable shows more variance on related indicator variable rather than share with other construct in the same model. The table 4.4 presents the covariance of the variables. Also, a composite reliability is fit if the variable measurement is .70 and above. The table 4.3 shows business performance composite reliability of 0.847; supply chain strategy composite reliability of 0.869 and demand and supply characteristics composite reliability of 0.843. All the three constructs composite reliability values were above 0.07 therefore the variables items are highly reliable.

*Table 4.3.1 Covariances of the variables*



			Estimate	S.E.	C.R.	P	Label
SCS	<-->	DSC	.263	.041	6.332	***	par_21
SCS	<-->	BP	.300	.043	6.995	***	par_22
BP	<-->	DSC	.248	.045	5.504	***	par_23

Note: SCS= Supply Chain Strategy, DSC= Demand Supply Chain Characteristics, BP= Business Performance.

The results presented in the table 4.4 indicate that the covariance value of both constructs is lower than 0.85, it means that the discriminant validity exists according to Haire et al. (2019). Also, the correlation value of Supply Chain Strategy and Demand Supply Chain Characteristics Discriminant Validity (DV) of: 0.760, Supply Chain Strategy Business Performance Discriminant Validity (DV) of 0.752, Supply Chain Strategy and Business Performance Discriminant Validity (DV) of 0.757 were greater than the inter-construct covariance therefore the three constructs had fulfilled the criteria of discriminant validity.

#### 4.4 Model Fit Summary

The model fit was also considered to confirm the initial validity and reliability tests. This was necessary for the testing of the model and the table 4.4 presents the results.

Table 4.4 Model Fit Summary

Model	NPAR	CMIN	DF	P	CMIN/DF
Default model	49	1745.813	227	.000	7.691
Saturated model	276	.000	0		
Independence model	23	5059.422	253	.000	19.998

<b>RMR, GFI</b>					
Model	RMR	GFI	AGFI	PGFI	
Default model	.087	.595	.508	.490	
Saturated model	.000	1.000			
Independence model	.336	.189	.115	.173	

<b>Baseline Comparisons</b>					
Model	NFI Delta1	RFI rho1	IFI Delta2	TLI rho2	CFI
Default model	.655	.615	.686	.648	.684
Saturated model	1.000		1.000		1.000
Independence model	.000	.000	.000	.000	.000

<b>Parsimony-Adjusted Measures</b>			
Model	PRATIO	PNFI	PCFI
Default model	.897	.588	.614
Saturated model	.000	.000	.000
Independence model	1.000	.000	.000

<b>NCP</b>				
Model	NCP	LO 90	HI 90	
Default model	1518.813	1389.577	1655.483	
Saturated model	.000	.000	.000	
Independence model	4806.422	4578.577	5040.656	
<b>FMIN</b>				
Model	FMIN	F0	LO 90	HI 90
Default model	6.955	6.051	5.536	6.596
Saturated model	.000	.000	.000	.000
Independence model	20.157	19.149	18.241	20.082
<b>RMSEA</b>				
Model	RMSEA	LO 90	HI 90	PCLOSE
Default model	.163	.156	.170	.000
Independence model	.275	.269	.282	.000
<b>AIC</b>				
Model	AIC	BCC	BIC	CAIC
Default model	1843.813	1854.174	2016.755	2065.755
Saturated model	552.000	610.361	1526.122	1802.122
Independence model	5105.422	5110.286	5186.599	5209.599
<b>ECVI</b>				
Model	ECVI	LO 90	HI 90	MECVI
Default model	7.346	6.831	7.890	7.387
Saturated model	2.199	2.199	2.199	2.432
Independence model	20.340	19.433	21.274	20.360
<b>HOELTER</b>				
Model	HOELTER	HOELTER		
	.05	.01		
Default model	38	41		
Independence model	15	16		

The study after achieving the discriminant and convergent validity also conducted the model fit because no single statistics is considered superior regarding assessment therefore a review of multiple fit indices is desirable. The values were as follows:  $X^2/df$  ( $p < 0.000$ );  $=PGFI=.490$ ;  $GFI=.595$  and  $AGFI=.508$  were within the recommended range ( $\leq 3$ ) (Hair et al., 1998).  $RMSEA$  was within acceptable values ranging from 0.05 to 0.08 (Hair et al., 1998). The  $CFI=.684$ ;  $TLI=.648$ ;  $IFI=.686$ ;  $RFI=.615$  AND  $NFI=.655$  had values exceeding 0.09 cutoff (Hair et al., 1998). The results of these alternative indices provided evidence of the overall validity of the hypothesized model.

#### 4.5 Hypotheses tests and results

The conceptual model was tested using structural equation modeling using IBM SPSS AMOS 25. The maximum likelihood method was adopted to estimate parameters. The figure 1 presents the correlation results among the variables.

#### 4.5.1 Correlation among the variables

The study first analyzed the correlation among the variables and the figure 1 presents the results.

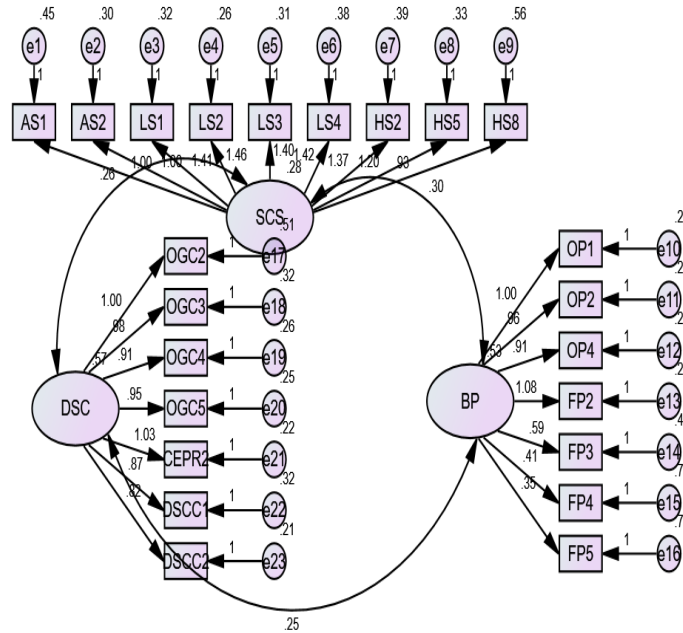

Figure 1 Correlation among the variables

Note: SCS= Supply Chain Strategy, DSC= Demand Supply Chain Characteristics, BP= Business Performance.

The relationship between demand and supply characteristics and business performance, the findings of the study indicate apposite correlation of about 25% between the demand and supply characteristics and business performance. The relationship between demand and supply characteristics and supply chain strategy, the findings of the study indicate apposite correlation of about 28% between demand and supply characteristics and supply chain strategy. Finally, the study also established a positive correlation of about 30% between supply chain strategy and business performance. The study further analyzed the influence of demand and supply characteristics on business performance, demand and supply characteristics on supply chain strategy and supply chain strategy on business performance. This was necessary because having a relationship does not warrant that an influence may exist therefore the study considered the influence of the independents variables on the dependent variables and the figure 2 presents the direct effect result.

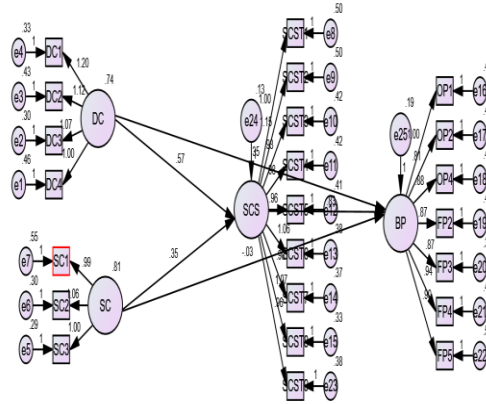
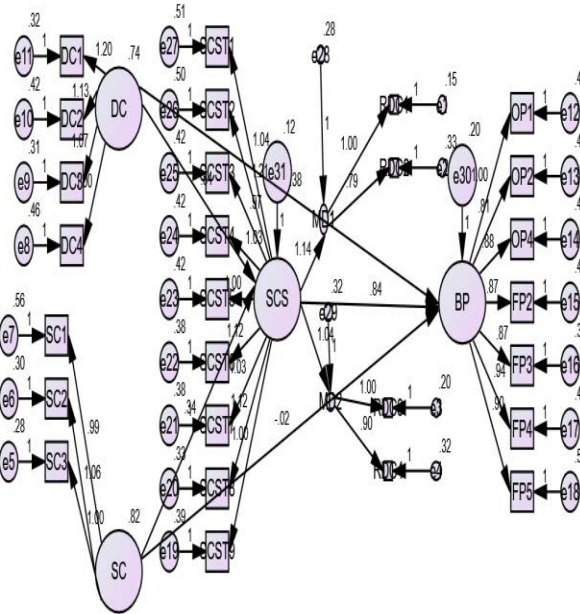

Figure 2 Direct effect hypothetical model for the study



Mediation effect hypothetical model for the study

Table 4.6 Structural Equation Modeling Results

Hypothesis	Relationship	Beta-value	T-value	P<	Remarks
H1	DC - ->SCS	.569	9.731	0.000	Supported
H2	SC - ->SCS	.350	8.061	0.000	Supported
H3	DC- -> BP	-.031	-.504	.614	Not supported
H4	SC- -> BP	-.124	-1.539	.124	Not supported
H5a	SCS - ->DC - ->BP	.367	5.439	0.000	Supported
H5b	SCS- -> SC- -> BP	.352	3.986	0.000	Supported

**5.0 CONCLUSIONS**

The study examined the effect of demand characteristics on supply chain strategy and the R Square indicates a variation of 74% to establish that demand characteristics is good predictor of supply chain strategy. Demand characteristics have the ability to influence supply chain strategy of about 74%. The statistical (Estimate = .569; Standard Error = .058; Critical Ratio = 9.731; P

<0.000) indicate that demand characteristics have a positive and significant effect on supply chain strategy.

The study examined the effect of supply characteristics on supply chain strategy and the R Square indicates a variation of 82% to establish that demand characteristics is good predictor of supply chain strategy. Supply characteristics have the ability to influence supply chain strategy of about 82%. The statistical (Estimate = .350; Standard Error = .043; Critical Ratio = 8.061; P <0.000) indicate that demand characteristics have a positive and significant effect on supply chain strategy.

The study examined the effect of supply chain strategy on business performance and the R Square indicates a variation of 84% to establish that supply chain strategy is good predictor of business performance. Supply chain strategy has the ability to influence business performance of about 84%. The statistical (Estimate = .828; Standard Error = .139; Critical Ratio = 5.972; P <0.000) indicate that supply chain strategy has a positive and significant effect on business performance.

The study examined the effect of supply characteristics on business performance and the R Square indicates a variation of -02% to establish that supply characteristics is not a good predictor of business performance. Supply characteristics do not have the ability to influence business performance positively. The statistical (Estimate = -.124; Standard Error = .081; Critical Ratio = -1.539; P <0.124) indicate that supply characteristics have a negative but insignificant effect on supply chain strategy.

The study examined the effect of demand characteristics on business performance and the R Square indicates a variation of -01% to establish that demand characteristics is not a good predictor of business performance. Demand characteristics do not have the ability to influence business performance positively. The statistical (Estimate = -.031; Standard Error = .062; Critical Ratio = -.539; P <0.614) indicate that demand characteristics have a negative but insignificant effect on supply chain strategy.

The study examined the mediating effect of supply chain strategy on the relationship between demand characteristics and business performance and the R Square indicates that supply chain strategy can overall mediates the relationship between demand characteristics and business performance of about 32% to establish that supply chain strategy is a good mediator of the relationship between demand characteristics and business performance. The statistical (Estimate = -.367; Standard Error = .067; Critical Ratio = 5.439; P <0.000) indicate that supply chain strategy positively and significantly mediates the relationship between demand characteristics and business performance.

The study examined the mediating effect of supply chain strategy on the relationship between supplier characteristics and business performance and the R Square indicates that supply chain strategy can overall mediates the relationship between supply characteristics and business performance of about 30% to establish that supply chain strategy is a good mediator of the relationship between supply characteristics and business performance. The statistical (Estimate = .352; Standard Error = .088; Critical Ratio = 3.986; P <0.000) indicate that supply chain strategy positively and significantly mediates the relationship between supply characteristics and business performance.



The study examined the effect of demand characteristics on supply chain strategy and the findings of the study indicate that demand characteristics has a positive and significant influence on supply chain strategy. Literature posits that a clear and comprehensive understanding of customer demand characteristics can help design optimal supply chains to reduce unnecessary complexity (Heikkilä 2002; Walters and Rainbird 2004; Jüttner, Christopher, and Baker 2007). The ability of organizations of reducing unnecessary complexity is a positive sign of achieving better performance.

Moreover, from a perspective of supply chain strategy, Fisher (1997) states that products based on their demand characteristics fit into two main categories: 'functional' and 'innovative'. Functional products need an efficient supply chain where the main objective of operational management is to reduce supply chain costs. On the other hand, innovative products require responsive supply chains that focus on flexibility and reduce lead time to fulfill customer demand. In line with Fisher (1997), Lee (2002) divides products into functional and innovative types based on demand uncertainty (low/ high) and separates supply into stable and evolving types based on supply chain uncertainty (low/high).

To deal with different levels of supply chain uncertainties, three key supply chain strategies are proposed: 'efficient', 'risk hedging', 'responsive', or 'agile'. Heikkilä (2002) argues that Fisher's (1997) structuring of the supply chains based on demand characteristics is overly simplistic. Separating the products into two categories is not feasible and seems to be problematic as many companies consider their products to be hybrid types (Lo and Power 2010). This is confirming why demand and supply characteristics have a positive and significant influence on the three dimensions of supply chain strategy because products demands are not the same and therefore requires different strategies to fulfill it.

### *5.1 Theoretical implication*

The theory driving this study is dynamic capability theory because according to this theory, firms must build, develop, integrate, and reconfigure their internal and external resources and competence for adapting to dynamic environments. Dynamic Capability Theory assumes that a firm can create a position for itself in the market by creating capabilities that can help it to perform better during environmental uncertainties. The demand and supply characteristics are to be carefully studied by organizations to apply the appropriate measures to help control or be abreast with the trend and respond appropriately.

A slight deviation will affect the performance of a business negatively. The right game plan of an organizations is very important to help apply the optimize demand and supply. The strategy supply guides organizations to be more dynamic to be able to respond to all situational changes to remain in business and achieve better performance. One approach may fail therefore managing demand and supply characteristics; organizations dynamic approach is the best to remain in business. Lean or agile supply chain strategy may not be applicable in all situations. The hybrid approach that pushes organizations to be more dynamic is good so that at where lean may not be applicable, agile approach may be perfect for firms to be in business. As the same may not be matched by its competitors and hence can be a source of competitive advantage for the firm (Teece, 2007).

A dynamic capability is defined as the capacity of a firm to create, extend, and modify its resources so as to fulfil a desired purpose (Helfat et al., 2007). The resources that are owned or controlled by a firm normally include its physical, human, and organizational assets (Eisenhardt and Martin, 2000). Dynamic capabilities are learned, and stable patterns of behaviour through which a firm systematically generates and modifies its way of doing things, so that it can become more effective (Zollo and Winter, 2002; Ambrosini et al., 2009). Supply chain flexibility can be conceptualized as a dynamic capability for several reasons including the following: it meets the criteria of being a higher-level capability (Winter, 2003); it is dedicated to the modification of operating routines (Zollo and Winter, 2002); it facilitates resource reconfiguration; and it enables sensing and capitalizing on environmental threats and opportunities (Tece, 2007).

### *5.2 Managerial implication*

Management of organizations should take note that supply chain strategy is an effective tool of achieving business performance. The effective implementation of the supply chain strategy is by considering the hybrid approach. This is where management of organizations will not stick to just one strategy but rather consider the hybrid to be able to respond to situations that may arise to mitigate their success. The implementation of the hybrid approach will help organizations to achieve better business performance by ensuring flexibility in meeting demands, receptive in meeting demands, adaptability means to meet demands, responsive to respond to changes in demands, cost reduction strategy in operations, waste reduction in operations and improvement products and services, improvement in delivery operations.

The management of organizations will achieve a better business operational, marketing and financial performance by developing of new ideas to help customers, organizations ability to fast track new offerings to customers, the ability to manage processes to keep costs down, ability to package a total solution to solve a customer problem, the ability to achieve an increase in market growth over years, the ability to increase in annual turnover over years and the ability to manage to achieve a better return on investment over the years.

Management of organizations can manage their demand and supply characteristics when they demonstrate the right organizational competence, ensure advanced market segmentation and develop the right expertise in the demand and supply processes. A typical supply chain strategy should be aimed at achieving a smooth flow at minimum cost.

### *5.3 Recommendations*

The management of organizations must ensure that they have the sophisticated market intelligence to help them gather relevant information that will help them to formulate better policies to help them be in business. Organizations failure to gather relevant information from the markets will find it extremely difficult to take good decisions that will help them to remain in business and detect issues that can have negative effect on the performances of their businesses. It is therefore very important for management in organizations to have sophisticated market intelligence to help them gather relevant information on time to help them take good decisions that will help them remain in business.

### *Cost and waste reduction management approach*

Management of organizations should consider the effective and efficient utilization of resources to reduce waste and cost of production to be able to improve on their profits. The companies in Ghana should adopt the cost reduction strategy in its operations so that they can compete globally and withstand competitions to remain in business and increase in market share and growth. Companies that are not able to reduce cost of production and waste reduction, will find it difficult to compete and may not even achieve profit because their cost of production will affect their profit maximization and quality of their products which may not give them any competitive advantage. They will also find it difficult to compete with their international counterparts. It is therefore extremely important for organizations in Ghana to take critical look at their cost of production and do everything possible to reduce it drastically and also reduce waste in their productions so that they can perform well and achieve profits.

#### *Periodic performance measurement*

Management in organizations should conduct a periodic performance measurement to be able to identify areas that they are doing well and where they also falling short so that they can look for the best solutions to remain in operations. Periodic performance measurement will help the organizations to consider their key performance indicators so that where they are not performing up to expectation, they will find a remedy to it. Sometimes, periodic performance measurement will even motivate workers to know where they are doing better as well as their short falls to help them think of how they can improve on their performance. Employees may think all is well if they are not doing periodic performance measurement. The performance measurement will draw the attention of the staff to know as to whether they are achieving their targets or not. This simply implies that organizations that fail to conduct a periodic performance measurement may not be able to detect where they are falling short so that they can work very hard to improve on their short falls on time therefore it could negatively affect their expectations and may also find it difficult to even detect where the problem is coming from especially where one issue may trigger down to affect others. It is therefore extremely important for organizations to conduct a periodic performance measurement to help them know their operational, market and financial performance.

#### *More able to solve customers' problem*

The global competition and customers' awareness of product and service functions, it is very important for organizations to quickly respond to customers problems so that they will maintain and gain more customers. Customers are the real marketers of products and services so their experience has the tendency to affect a product or service positively or negatively. In a situation that organizations may fail to respond to their problems, they will never recommend that particular service or product to a new customer. It is therefore very important for organizations to attend to them on time so that they will also give good testimonies about the product or the service to the new and existing customers who may look for an alternative organization. It is very difficult to win customer than to lose ten customers therefore organizations should respond to their customers so that they do not end up losing them to their competitors to achieve better financial and market performance.

#### *5.6 Areas for future studies*

This study considered the mediating effect of supply chain strategy on the relationship between demand and supply chain characteristics and business performance therefore a future study

can look at the moderating role of information technology on the relationship between supply chain strategy and business performance.

## REFERENCES

- 1) Ackah, D., Addo, K. S., K., Yornu, K. I., (2024), "Effect of Green Procurement Practices on Financial Performance", African Journal of Procurement, Logistics & Supply Chain Management, 2024, 7(8): pp.13-40. DOI: <https://dx.doi.org/10.4314/ajplscm.v7i8.2>
- 2) Ackah, D., Addo, K. S., K., Yornu, K. I., (2024), "Enforcing Ethical Codes of Conduct in Procurement and Its Impact on Public Procurement Performance in Ghana", African Journal of Procurement, Logistics & Supply Chain Management 2024, 7(8): pp.72-92. DOI: <https://dx.doi.org/10.4314/ajplscm.v7i8.5>
- 3) Ackah, D., Addo, K. S., K., Yornu, K. I., (2024), "Senior Management's Influence on Supplier Selection and Procurement Performance", African Journal of Procurement, Logistics & Supply Chain Management, 2024, 7(8): pp. 93-113. DOI: <https://dx.doi.org/10.4314/ajplscm.v7i8.6>
- 4) Ackah, D., Dadzie. B., E., Yornu, K. I., (2024), "The Influence of Corporate Governance on Strategic Procurement and Competitive Advantage", African Journal of Procurement, Logistics & Supply Chain Management, 2024, 7(8): pp.13-40. DOI: <https://dx.doi.org/10.4314/ajplscm.v7i8.7>
- 5) Agarwal, R. (2013). *Development of a scale to measure consumer perception of sustainability in fashion industry*. Journal of Business Research, 66(1), 123-128. <https://doi.org/10.1016/j.jbusres.2011.05.018>
- 6) Aitken, J., Childerhouse, P., & Towill, D. (2005). Customer-driven supply chains: A model for managing supply chain complexity. *Supply Chain Management: An International Journal*, 10(2), 91-101. <https://doi.org/10.1108/13598540510596966>
- 7) Aitken, J., Childerhouse, P., & Towill, D. R. (2005). Designing the supply chain for customer satisfaction. *The International Journal of Logistics Management*, 16(3), 15-30.
- 8) Amin, S., & Zhang, J. (2013). A framework for supply chain design under uncertainty. *International Journal of Production Economics*, 145(2), 563-571.
- 9) Amin, S., & Zhang, Z. (2013). Supply chain design under uncertainty: A review. *International Journal of Production Research*, 51(1), 114-137. <https://doi.org/10.1080/00207543.2012.658059>
- 10) Arshinder, K., Kanda, A., & Deshmukh, S. G. (2008). Supply chain coordination: A review of literature. *International Journal of Production Research*, 46(20), 5745-5770.
- 11) Avolio, R., Bandinelli, R., & Rinaldi, R. (2015). Supply chain collaboration in the fashion industry. *Journal of Fashion Marketing and Management*, 19(3), 311-330. <https://doi.org/10.1108/JFMM-03-2014-0034>

- 12) Baker, G. P. (1992). Rewarding Managers in a Complex World. In J. E. McMillan (Ed.), *The Economics of Information and Uncertainty* (pp. 1-25). Chicago: University of Chicago Press.
- 13) Ben Naylor, B. J., Naim, M. M., & Berry, D. (1999). *Leagility: Interfacing the lean and agile manufacturing paradigms in the supply chain*. *International Journal of Production Economics*, 62(1-2), 107-118.
- 14) Bernard, H. R. (2002). *Research methods in anthropology: Qualitative and quantitative approaches* (3rd ed.). Altamira Press. Lescroël, A., et al. (2014). *Understanding data collection methods in research*. *Journal of Research Methods*, 9(2), 45-56.
- 15) Bernard, H. R. (2002). *Research methods in anthropology: Qualitative and quantitative approaches*. Rowman Altamira.
- 16) Bharadwaj, S. G., Varadarajan, R., & Fahy, J. (1993). *Sustainable competitive advantage in service industries: A conceptual model and research propositions*. *Journal of Marketing*, 57(4), 83-99.
- 17) Bhattacharjee, A. (2012). *Social science research: Principles, methods, and practices*. OpenStax College. Retrieved from OpenStax
- 18) Bless, C., & Higson-Smith, C. (2004). *Fundamentals of social research methods: An African perspective*. Juta & Company Ltd.
- 19) Borade, A. B., & Nansod, D. P. (2007). *Strategic Issues in Supply Chain Management*. *International Journal of Management and Strategy*, 4(1), 112-121.
- 20) Bowersox, D. J. (2000). *Logistics management: The integrated supply chain process*. McGraw-Hill Education.
- 21) Bowersox, D. J., & Closs, D. J. (1996). *Logistical Management: The Integrated Supply Chain Process*. McGraw-Hill.
- 22) Brun, A., & Pero, M. (2012). Supply chain choices in the fashion industry: Aligning supply chain strategy with product variety. *International Journal of Production Economics*, 135(2), 647-658.
- 23) Bureau of Labor Statistics Ghana. (2017). *Employment statistics*.
- 24) Cabral, J. A., Sweeney, E., & Tavares, S. (2012). Resilience in the supply chain: A review of the literature. *International Journal of Production Economics*, 137(1), 1-15. <https://doi.org/10.1016/j.ijpe.2012.01.020>
- 25) Campbell, D. T., & Fiske, D. W. (1959). *Convergent and discriminant validation by the multitrait-multimethod matrix*. *Psychological Bulletin*, 56(2), 81-105. <https://doi.org/10.1037/h0046016>



- 26) Childerhouse, P., & Towill, D. R. (2002). Annex 3: The impact of demand chain management on the supply chain. *Production Planning & Control*, 13(2), 89-97. <https://doi.org/10.1080/09537280110107437>
- 27) Chopra, S., & Meindl, P. (2007). *Supply Chain Management: Strategy, Planning, and Operation* (3rd ed.). Upper Saddle River, NJ: Pearson Prentice Hall. Chopra, S., & Meindl, P. (2010). *Supply Chain Management: Strategy, Planning, and Operation* (4th ed.). Upper Saddle River, NJ: Pearson Prentice Hall.
- 28) Chopra, S., & Meindl, P. (2007). Supply chain management: Strategy, planning, and operation. *Pearson Prentice Hall*.
- 29) Chopra, S., & Meindl, P. (2019). Supply Chain Management: Strategy, Planning, and Operation. Pearson.
- 30) Christopher, M. (2000). *The agile supply chain: competing in volatile markets*. *Industrial Marketing Management*, 29(1), 37-44.
- 31) Christopher, M. (2005). Logistics and Supply Chain Management (3rd ed.). Financial Times/Prentice Hall.
- 32) Christopher, M. (2016). Logistics and Supply Chain Management (5th ed.). Pearson.
- 33) Christopher, M., & Peck, H. (2006). *Building the resilient supply chain*. *International Journal of Logistics Management*, 16(2), 1-14.
- 34) Clark, T. (1999). *Business performance: a multi-dimensional approach*. *International Journal of Business Performance Management*, 1(1), 1-15.
- 35) Cooper, M. C., Lambert, D. M., & Pagh, J. D. (1997). Supply Chain Management: More Than a New Name for Logistics. *International Journal of Logistics Management*, 8(1), 1-14. <https://doi.org/10.1108/09574019710805556>
- 36) Creswell, J. W. (2014). *Research design: Qualitative, quantitative, and mixed methods approaches* (4th ed.). SAGE Publications.
- 37) Creswell, J. W. (2014). *Research design: Qualitative, quantitative, and mixed methods approaches*. SAGE Publications.
- 38) Creswell, J. W., & Plano Clark, V. L. (2011). *Designing and conducting mixed methods research* (2nd ed.). SAGE Publications.
- 39) Cronbach, L. J. (2004). *Two faces of validity: Stability and generalizability*. *Educational and Psychological Measurement*, 64(5), 743-757. <https://doi.org/10.1177/0013164404263589>
- 40) D'Avolio, A., Bandinelli, R., & Rinaldi, L. (2015). Collaborative supply chain management in the fashion industry: How to deal with demand uncertainty. *Journal of Fashion Marketing and Management*, 19(2), 195-209.

- 41) David, F. R., David, F. R., & David, M. (2006). Strategic management: Concepts and tools for creating real competitive advantage. *Prentice Hall*.
- 42) De Vaus, D. A. (2001). *Research design in social research*. SAGE Publications.
- 43) Demirbag, M., Tatoglu, E., & S. C. (2006). The impact of quality management practices on performance: A study of Turkish manufacturing firms. *Journal of Quality in Maintenance Engineering*, 12(3), 202-215.
- 44) Ellinger, A. E., & Ellinger, R. W. (2014). The role of supply chain management in firm performance: A focus on human resource management. *Journal of Business Logistics*, 35(2), 122-140.
- 45) ElMaraghy, H. A., & Mahmoudi, A. (2009). Supply chain configuration in a geographically dispersed environment. *International Journal of Production Research*, 47(21), 6119-6139. <https://doi.org/10.1080/00207540802112261>
- 46) Fawcett, S. E., Ogden, J. A., & Magnan, G. M. (2007). *The role of supply chain management in the success of the firm*. *Journal of Business Logistics*, 28(1), 5-29.
- 47) Fisher, M. L. (1997). What is the right supply chain for your product? *Harvard Business Review*, 75(2), 105-116.
- 48) Fisher, M. L. (1997). *What is the right supply chain for your product?* Harvard Business Review, 75(2), 105-116.
- 49) Flynn, B. B., Huo, B., & Zhao, X. (2010). *The impact of supply chain integration on performance: A contingency and configuration approach*. *Journal of Operations Management*, 28(1), 58-71.
- 50) Fornell, C., & Larcker, D. F. (1981). *Evaluating structural equation models with unobservable variables and measurement error*. *Journal of Marketing Research*, 18(1), 39-50. <https://doi.org/10.1177/002224378101800104>
- 51) Frankforter, S. A., Davy, J. A., & Sweeney, P. J. (2000). *Shareholder Value and the Stockholder-Manager Relationship: A Dual Perspective*. *Strategic Management Journal*, 21(3), 313-329.
- 52) Furr, M., & Bacharach, V. (2003). *Psychometrics: An introduction*. SAGE Publications.
- 53) Gibilaro, L., & Mattarocci, G. (2019). The role of supply chain management in achieving competitive advantage. *International Journal of Logistics Management*, 30(3), 780-802.
- 54) Goodman, P. S., & Dienesch, R. M. (1983). *Theoretical and Methodological Issues in the Study of Organizational Performance*. *Research in Organizational Behavior*, 5, 123-157.
- 55) Greer, M. J., & Theuri, P. (2012). Supply chain management: A strategic approach. *Journal of Business Research*, 65(3), 435-441.

- 56) Hair, J. F., Anderson, R. E., Tatham, R. L., & Black, W. C. (1998). *Multivariate data analysis* (5th ed.). Prentice Hall.
- 57) Handfield, R. B., Monczka, R. M., Giunipero, L. C., & Peterson, K. J. (2009). *Supply Chain Management: A Strategic Perspective*. *Journal of Business Logistics*, 30(2), 11-14.
- 58) Heikkilä, J. (2002). *From supply to demand chain management: A transformation of the management paradigm in supply chains*. *Supply Chain Management: An International Journal*, 7(5), 251-263. <https://doi.org/10.1108/13598540210450834>
- 59) Heikkilä, J. (2002). From supply to demand chain management: Efficiency and customer satisfaction. *Journal of Operations Management*, 20(6), 747-764.
- 60) Heizer, J., & Render, B. (2010). *Operations management*. Pearson Prentice Hall. Hong, P., & Jeong, J. (2021). Supply chain strategies for enhancing business performance: Evidence from the pharmaceutical industry. *Supply Chain Management: An International Journal*, 26(4), 597-612.
- 61) Hilletoft, P., & Eriksson, D. (2011). A framework for demand-driven supply chain management. *International Journal of Logistics Research and Applications*, 14(5), 347-367. <https://doi.org/10.1080/13675567.2011.609133>
- 62) Hoang, T. H., Luan, V. Q., & Hung, N. T. (2006). *A study on the impact of logistics service quality on customer satisfaction*. The 3rd International Conference on Logistics and Supply Chain Management.
- 63) Holmstrom, B. (1979). *Moral Hazard and Observability*. *The Bell Journal of Economics*, 10(1), 74-91.
- 64) Holmstrom, B. (1987). *Aggregation and Linearity in Continuous Time Models*. *Journal of Economic Theory*, 43(1), 138-153.
- 65) Hu, Y., Gurnani, H., & Wang, X. (2013). Supply chain disruptions: A review and future research directions. *International Journal of Production Research*, 51(7), 2093-2115. <https://doi.org/10.1080/00207543.2011.643092>
- 66) Huang, G. Q., Uppal, M., & Shi, L. (2002). Supply chain strategy selection: A case study. *Supply Chain Management: An International Journal*, 7(1), 24-32. <https://doi.org/10.1108/13598540210418438>
- 67) Hunt, S. D., & Morgan, R. M. (1995). *The Comparative Advantage Theory of Competition*. *Journal of Marketing*, 59(2), 1-15.
- 68) Igarria, M., Zinatelli, N., Cragg, P., & Cavaye, A. (1997). *Personal computing acceptance factors in small firms: A structural equation model*. *International Journal of Management Science*, 25(3), 215-229. [https://doi.org/10.1016/S0305-0483\(97\)00001-0](https://doi.org/10.1016/S0305-0483(97)00001-0)

- 69) Igwenagu, I. C. (2016). *Research methodology: A step-by-step approach*. 1st ed. Nimo: Rex Charles and Patrick Limited.
- 70) Igwenagu, I. N. (2016). *Research methodology: A step-by-step guide for beginners*. Lambert Academic Publishing.
- 71) Ionescu, S., Topor, R., & Gulea, A. (2019). *Supply chain management processes: Linking customer relationship and order fulfillment*. *Management and Marketing*, 14(2), 156-169.
- 72) Jacobsen, R. (1987). *The robustness of the Return on Investment (ROI) as a performance measure: An empirical test of the relationship between ROI and the "bottom line"*. *Academy of Management Journal*, 30(3), 526-543.
- 73) Jensen, M. C., & Meckling, W. H. (1976). *Theory of the Firm: Managerial Behavior, Agency Costs, and Ownership Structure*. *Journal of Financial Economics*, 3(4), 305-360.
- 74) Jüttner, U., Christopher, M., & Baker, S. (2007). Demand chain management: Integrating marketing and supply chain management. *Industrial Marketing Management*, 36(3), 377-392. <https://doi.org/10.1016/j.indmarman.2006.04.003>
- 75) Jüttner, U., Christopher, M., & Baker, S. (2007). Demand chain management: Understanding supply chain management. *Supply Chain Management: An International Journal*, 12(3), 209-214.
- 76) Kaipia, R., & Holmström, J. (2007). Demand chain management: The challenge of supply chain design. *International Journal of Production Economics*, 107(1), 285-295.
- 77) Kaipia, R., & Holmström, J. (2007). The role of demand information in supply chain management. *International Journal of Production Research*, 45(9), 2103-2118. <https://doi.org/10.1080/00207540600720106>
- 78) Kamaruddin, S., Zain, Z., & Mohamad, M. (2009). *Managing Complexity in Supply Chains: A Study of Factors Affecting the Complexity of Supply Chains*. *International Journal of Logistics Research and Applications*, 12(4), 233-248.
- 79) Kaplan, R. S., & Norton, D. P. (1996). *The Balanced Scorecard: Translating Strategy into Action*. Boston, MA: Harvard Business School Press.
- 80) Kaplan, S. (2014). Business strategy: The end of the road. *Harvard Business Review*, 92(12), 89-95.
- 81) Kim, Y. (2012). The impact of supply chain management practices on competitive capabilities and firm performance. *Journal of Supply Chain Management*, 48(3), 80-94.
- 82) Klemencic, A. (2006). *Supply Chain Management: A Review of Literature and a Proposed Research Agenda*. *International Journal of Business and Management Studies*, 1(1), 7-22.
- 83) Kothari, C. R. (2003). *Research methodology: Methods and techniques* (2nd ed.). New Age International.

- 84) Kothari, C. R. (2004). *Research methodology: Methods and techniques* (2nd ed.). New Age International.
- 85) Krajewski, L. J., Ritzman, L. P., & Malhotra, M. K. (2007). *Operations Management: Processes and Supply Chains* (8th ed.). Upper Saddle River, NJ: Pearson Prentice Hall.
- 86) Kumar, R. (2008). *Research methodology: A step-by-step guide for beginners* (2nd ed.). SAGE Publications.
- 87) La Londe, B. J., & Cooper, M. C. (1989). Partnering to strengthen the supply chain. *International Journal of Logistics Management*, 1(2), 1-10. <https://doi.org/10.1108/09574098910834566>
- 88) Lambert, D. M. (2006). *Supply Chain Management: Processes, Partnerships, Performance* (3rd ed.). Sarasota, FL: Supply Chain Management Institute.
- 89) Lambert, D. M. (2008). *Supply Chain Management: Processes, Partnerships, Performance* (4th ed.). Sarasota, FL: Supply Chain Management Institute.
- 90) Lau, H., Lee, M. K., & Chan, F. (2002). The role of trust in supply chain management: A case study in the UK. *Supply Chain Management: An International Journal*, 7(4), 177-184.
- 91) Lee, H. L. (2002). *Aligning supply chain strategies with product uncertainties*. California Management Review, 44(3), 105-119. <https://doi.org/10.2307/41166169>
- 92) Lescroël, A., Labrosse, P., & Legrand, B. (2014). *Data collection for social science research: A practical guide*. Routledge.
- 93) Lieb, R. C., & Randall, H. L. (2017). A review of third-party logistics research: A service provider perspective. *International Journal of Logistics Management*, 28(1), 232-253.
- 94) Lo, C. K. Y., & Power, D. J. (2010). *A research framework for supply chain management in the context of the 21st century*. Supply Chain Management: An International Journal, 15(1), 16-23. <https://doi.org/10.1108/13598541011022854>
- 95) Macdonald, J. R., & Corsi, T. M. (2013). The role of uncertainty in supply chain design. *Transportation Research Part E: Logistics and Transportation Review*, 50, 1-9. <https://doi.org/10.1016/j.tre.2012.10.002>
- 96) Martin, M., & Patterson, D. (2009). Supply chain strategy and financial performance: An empirical investigation. *International Journal of Operations & Production Management*, 29(2), 117-131.
- 97) Mason-Jones, R., Naylor, B. J., & Towill, D. R. (2000). Engineering the lean supply chain. *International Journal of Agile Management Systems*, 2(1), 54-61. <https://doi.org/10.1108/14654650010353126>



- 98) Mason-Jones, R., Naylor, B. J., & Towill, D. R. (2000). Engineering the leagility in the supply chain. *International Journal of Agile Management Systems*, 2(1), 54-61.
- 99) Mavrincac, S. C., & Siesfeld, G. (1997). *The Financial Performance of Business Units: A New Framework for Analysis*. *Journal of Management Accounting Research*, 9, 1-27.