

Full Length Research Paper

Development of loop-mediated isothermal amplification method for visualization detection of the highly virulent strains of porcine reproductive and respiratory syndrome virus (PRRSV) in China

Yuewei Zhang¹, Ping Fu¹, Jiahe Li¹, Fei Jiang¹, Jinxiang Li² and Wenxue Wu^{1*}

¹College of Veterinary Medicine, China Agricultural University, Beijing, China.

²Chinese Academy of Agricultural Sciences, Beijing, China.

Accepted 24 August, 2011

A novel assay method to detect the highly virulent Porcine reproductive and respiratory syndrome virus (PRRSV) termed reverse transcriptase loop-mediated isothermal amplification (RT-LAMP), was reported by using hydroxynaphthol blue (HNB) as the LAMP product colorimetric judgment. By the set of special primers, targeting the sequence that belongs to *Nsp2* gene containing an 87 bp deletion mutation, the LAMP-based assay could be completed within 1 h at 63°C. Final concentration of 150 mM HNB was confirmed to be appropriate in LAMP product judgment without impact on the reaction system. The detection limit of the assay was 10³ copies per reaction, as determined by using a recombined plasmid. Genomes of various viruses were used to confirm the specificity of the LAMP-based assay, but only the highly virulent strains of PRRSV could be detected. All the internal organs from three stillborn piglets from a herd of pigs with PRRS-like symptoms were confirmed by LAMP-based assay to be infected not only with classical PRRSVs, but also the variant strains. These results suggest that the RT-LAMP assay with HNB provides a useful tool for the diagnosis of the highly virulent PRRSV infections in porcine rapidly.

Key words: Reverse transcriptase loop-mediated isothermal amplification (RT-LAMP), highly virulent porcine reproductive and respiratory syndrome virus (PRRSV), classical porcine reproductive and respiratory syndrome virus (PRRSV), hydroxynaphthol blue (HNB).

INTRODUCTION

Porcine reproductive and respiratory syndrome virus (PRRSV) is a small, enveloped, single-stranded positive sense RNA virus, and can be classified as a member of the genus Arterivirus of the family Arteriviridae (Benfield, 1992). There are two major prototypes of PRRSV; type I representing the European prototype (Lelystad virus, LV), and type II with the Northern American strain ATCC VR2332 as a prototype (Benfield, 1992; Bautista et al., 1993; Meulenbergh et al., 1993). This virus was first discovered in the USA in 1987 and subsequently in Europe (Albina, 1997). Then, in early 1990s, the virus

was identified in Asia (Murakami et al., 1994; Tian et al., 2007). PRRSV was first confirmed in China in 1996 and later became widely spread. Most of the isolations in China, including the variant strains with high pathogenicity, had been identified as the member of the Northern American strain (Gao et al., 2004; Chen et al., 2006; Tian et al., 2007).

The genome of PRRSV is about 15 kb in length and contains nine open reading frames (ORFs). ORF1 encodes non-structural proteins (Nsp2), ORF2-ORF5 encodes structural glycoproteins (GP2-5), ORF6 encodes the matrix (M) protein and ORF7 encodes the nucleocapsid (N) protein (Meulenbergh et al., 1993; Murtaugh et al., 1995). As shown by previous studies, an 87 bp fragment deletion in *nsp2* gene was implicated in the highly virulent PRRSV (Li et al., 2007; Tian et al., 2007).

*Corresponding author. E-mail: wuwenxue@cau.edu.cn. Tel: 86-10-62733048. Fax: 86-10-62733048.

Normally, PRRSV infection can cause porcine reproductive and respiratory syndrome (PRRS), which is characterized by reproductive failure in sows as well as respiratory disease in piglets and growing pigs (Stevenson et al., 1993; Rossow, 1998). However, in 2006, during the outbreaks of this disease caused by the highly virulent PRRSV, numerous adult sows were also infected by this atypical pathogen. The symptoms of the atypical PRRS involved shivering, high fever, erythematous blanching rash, etc., which looked like the disease of hog cholera (Tian et al., 2007).

Apparently, there are few methods developed for specific diagnosis of highly virulent PRRSV. Conventional RT-PCR based on electrophoresis could distinguish the variant PRRSV from the normal PRRSV according to the different product size (Hao et al., 2007). Then, real-time PCR based on specific probes was able to directly detect the highly virulent PRRSV (Xiao et al., 2008; Chen et al., 2009). Furthermore, this kind of probes could also be used in microarray assay for differentiating diagnosis of the highly virulent PRRSV (Guo et al., 2010). Loop-mediated isothermal amplification (LAMP), as a novel assay method, can amplify specific DNA sequences with high efficiency (Notomi et al., 2000). Chen et al. (2009) developed a LAMP-based assay according to a set of four primers targeting the conserved regions of ORF1a gene (Chen et al., 2009). In their study, though the method could amplify the ORF1a gene of the highly virulent PRRSV with high sensitivity, there were no further data to ascertain the specificity of the LAMP primers only targeting the highly virulent strains.

In this study, the development of a reverse transcriptase-LAMP (RT-LAMP) assay for highly virulent PRRSV based on its characteristics of *Nsp2* gene fragment were described and this method was shown to be specific and efficient. Furthermore, the validation of a visualization indicator, called hydroxynaphthol blue (HNB) was also investigated.

MATERIALS AND METHODS

Target sequence and primers

Six primers of F3, B3, FIP, BIP, LF and LB for the LAMP method were designed using the LAMP primer designing software (Primer explorer, Japan). All the primers were designed targeting *Nsp2* gene fragment of one strain of highly virulent PRRSV (accession no. EF075945) and listed in Figure 1a. The 87 bp deletion mutation (genome position: 2929) was located between the F2 region and the LFc. The primers were synthesized by Sangon Biotech (Shanghai) Co., Ltd.

LAMP reaction

A universal system was used in the RT-LAMP method. The reaction was carried out in a 25 μ L final mixture containing 0.8 M betaine (Sigma), 20 mM Tris-HCl (pH 8.8), 10 mM KCl, 8 mM MgSO₄, 10 mM (NH₄)₂SO₄, 0.1% Tween 20, 2.8 mM each dNTP, 16 U *Bst* DNA polymerase (New England Biolabs) and 0.2 U AMV reversed

transcriptase (Promega). The primers in the reaction mix contained 40 pM (each) of FIP and BIP, 5 pM (each) of F3 and B3, and 20 pM (each) of LF and LB. The reaction mixture with 2 μ L template was incubated at 63°C for 60 min in a Loopamp real-time turbidimeter (LA-200; Teramecs). The machine could record the optical density at 400 nm through spectrophotometric analysis. Positive results were determined by taking into account the time of positivity, when the turbidity increased above the threshold value fixed at 0.1. As for the mixtures with HNB, a simple isothermal heater was used and the results were directly judged by eyes.

HNB as a visualization indicator

HNB (Sigma) was dissolved in distilled water at 20 mM to prepare a stock solution, and a serially diluted HNB solution was prepared with distilled water from the stock solution. Different concentrations of HNB including 50, 100, 120, 150 and 200 mM, were separately added to the 25 μ L mixture. After amplification was completed, the colour was assessed by eyes. The optimal concentration of HNB (150 mM) was also used in sensitivity and specificity test as well as analysis of clinic samples.

Sensitivity and specificity test

A standard plasmid containing the target sequence was constructed in order to detect the sensitivity of the LAMP method. A pair of PCR primers (Forward: 5'-CCCTCCACCAAGAGTTCAACC-3', Backward: 5'-ACGCATCACAAGCCTCAGC-3') were designed to get a PCR fragment of the target sequence (a 629 bp fragment of *Nsp2* gene). The fragment was cloned into *pEASY T1 Simple* vector (TransGen) according to the instructions of the manufacturer. The constructed plasmids were propagated in TOP10 competent cell (TransGen) and were purified by EasyPure Mini Plasmid Purification Kit (TransGen) and by measuring OD₂₆₀ value using *DU 800* Nucleic Acid/Protein Analyzer (BECHMAN COULTER). Ten-fold dilutions were prepared for affording 10⁶ to 10⁰ copies per reaction for LAMP reaction. The specificity of LAMP was demonstrated by the utilization of classical PRRSV, *Porcine parvoviruses* (PPV), *Actinobacillus pleuropneumoniae* (APP), *Mycoplasma hyopneumoniae* (Mhp), classical swine fever virus (CSFV), Pseudorabies virus (PRV) and foot-and-mouth disease virus (FMDV), which causes similar reproductive or respiratory symptoms in pigs.

Clinic sample

The internal organs of three stillborn piglets including lymph nodes, kidney, spleen lung and liver were collected and stored at -80°C from a pig farm in Shandong province of China which suffered the outbreak of PRRS characterized by stillborn piglets, mummified fetuses and high fever. The total RNA of these tissues was extracted and purified by a Total RNA Mini Kit (GeneAid). After eluted with 50 μ L of RNase-free water, the purified RNA was stored at -80°C. An aliquot of 2 μ L RNA was applied to each reaction tube for RT-LAMP incubated at 63°C for 60 min in a simple isothermal heater. An RT-LAMP-based assay for diagnosis of classical PRRSV, according to our previous work (Zhang et al., 2010) was also carried out for the same samples.

RESULTS

Validation of HNB

In this study, HBN was used as a colorimetric indicator;

(a)

Primer name	Genome position	Sequence(5' - 3')
F3	2884-2902	CCTTTGAGTGGGTCAGCAC
B3	3089-3106	GTGCAGGGTTGGTGTCAIT
FIP*	F1c 2953-2972 F2 2904-2922	GCAGACAAATCCAGAGGCTC-tttt-AGTTCCTGCACCGCGTAGA
BIP*	B1c 3003-3022 B2 3052-3071	CCTAGCACCGTTCGCAGAACA-tttt-TCACTCAGGACTTCCTCAGC
LF	2933-2949	CTGGTGCGTCAGCGTTG
LB	3022-3039	ATGGGCATCCTGGAGGCG

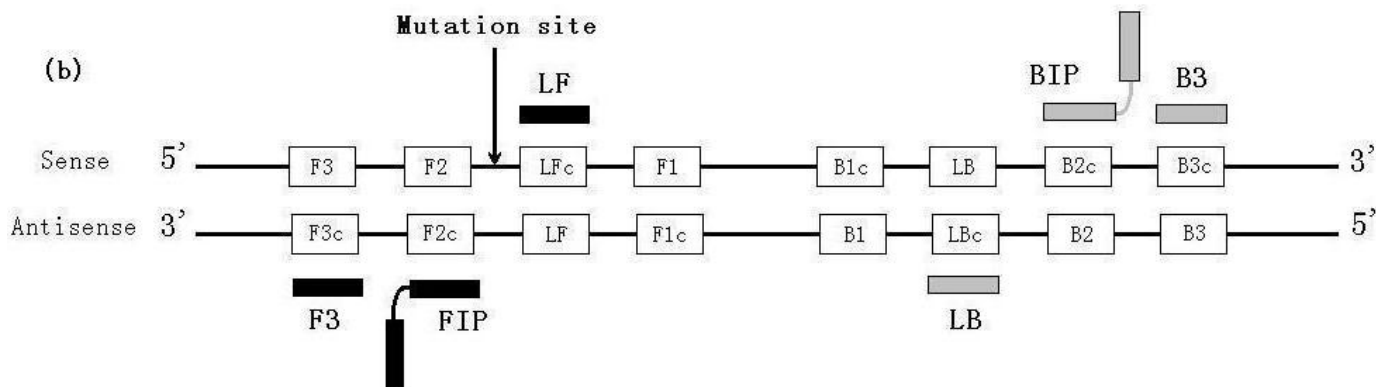

Figure 1. Primers designed for LAMP. (a)Details of LAMP primers targeting *Nsp2* gene; (b) The binding regions of LAMP primers. The mutation site was located between the F2 region and the LFc.*FIP and BIP are inner primers using a TTTT spacer to connect two binding regions. (FIP is composed of 5'-F1c-TTTT-F2-3' and BIP is composed of 5'-B1c-TTTT-B2-3').

the colour of the positive reaction changed from violet to sky blue as shown in Figure 2a, and the colour of both positive and negative mixtures became deeper in accord with the increasing concentration of HNB. The final concentration of 150 mM HNB was chosen for subsequent experiment based on the bright colour and significant difference between positive samples and negative samples. Additionally, the sensitivity test of the reaction system with HNB suggested that HNB at the concentration of 150 mM was available in the judgment of RT-LAMP result without inhibition of the reaction (Figure 2b).

Sensitivity and specificity

To evaluate the sensitivities of the RT-LAMP method, the 10-fold serial diluted recombinant plasmids were subjected to the RT-LAMP reaction both with and without 150 mM HNB in the final mix. As indicated in the result,

both systems could detect down to 10^3 copies per reaction, indicating that HNB added into the tube before incubation had no influence on the sensitivity of the RT-LAMP-based assay (Figures 3 and 2b). According to the result of specificity test as shown in Figure 2c, only the highly virulent PRRSV was detected as a positive result of colour change, while the genome of other pathogens, including the classical PRRSV without mutation in *Nsp2* gene, could not be amplified in the developed RT-LAMP system.

Test of clinic samples

Lymph node, kidney, spleen, lung and liver samples of three stillborn piglets from a herd of pigs with PRRS-like symptoms were collected for the diagnosis of the variant PRRSV as well as for the identification of the classical PRRSV using a published method (Zhang et al., 2010). As shown in Table 1, all the samples were confirmed to

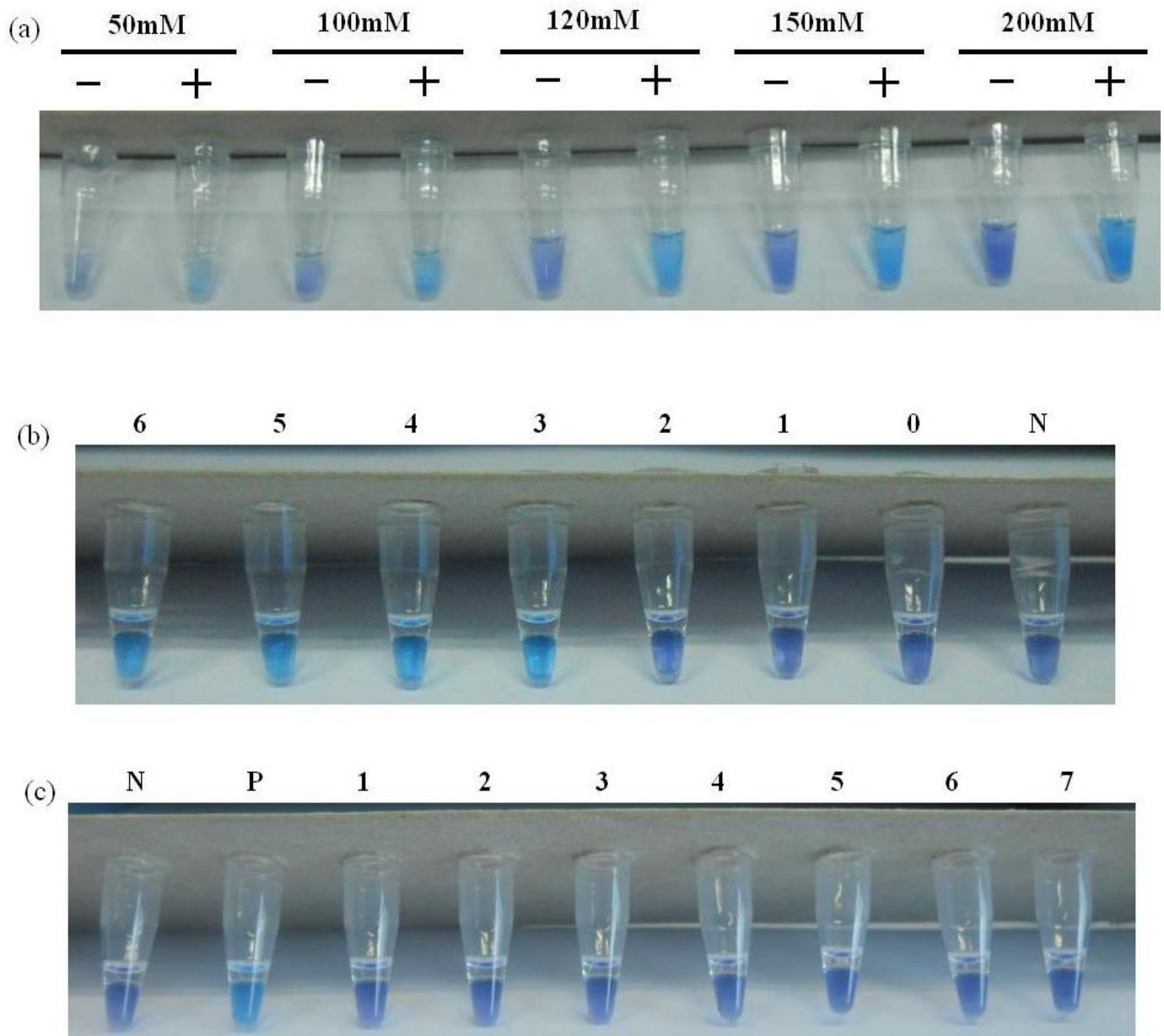

Figure 2. Validation of HNB. (a) Optimization of HNB concentration; the concentration for each reaction is shown at the top. (b) Sensitivity of RT-LAMP method using 150 mM HNB (6 to 0: 10^6 , 10^5 , 10^4 , 10^3 , 10^2 , 10^1 , 100 copies per reaction). N, negative control. (c) Specificity of RT-LAMP method using 150 mM HNB. N, Negative control. P, positive control using the variant PRRSV RNA; 1 to 7, classical PRRSV, *Porcine parvoviruses* (PPV), *Actinobacillus pleuropneumoniae* (APP), *Mycoplasma hyopneumoniae* (Mhp), Classical Swine Fever virus (CSFV), Pseudorabies virus (PRV) and foot-and-mouth disease virus (FMDV), respectively.

be infected with PRRSV, some of which might be also infected with the highly virulent strains.

DISCUSSION

A set of well-designed primers are critical for the efficiency of LAMP, and the distance between primers is one of the key factors in LAMP primer design. Previous works have shown that the appropriate distance from 5'

end of F2 to the 5' end of F1 was between 40 and 60 bp (Notomi et al., 2000). The primers used in our research practically hybridized to the genome of both highly virulent and classical PRRSV. However, the distance between F2 and F1 would become more than 100 bp because of an additional 87 bp fragment which was deleted in *nsp2* gene of the variant stains. As a result, the amplification with the same primers could not occur when using the classical PRRSV as the target pathogen (Figure 2c).

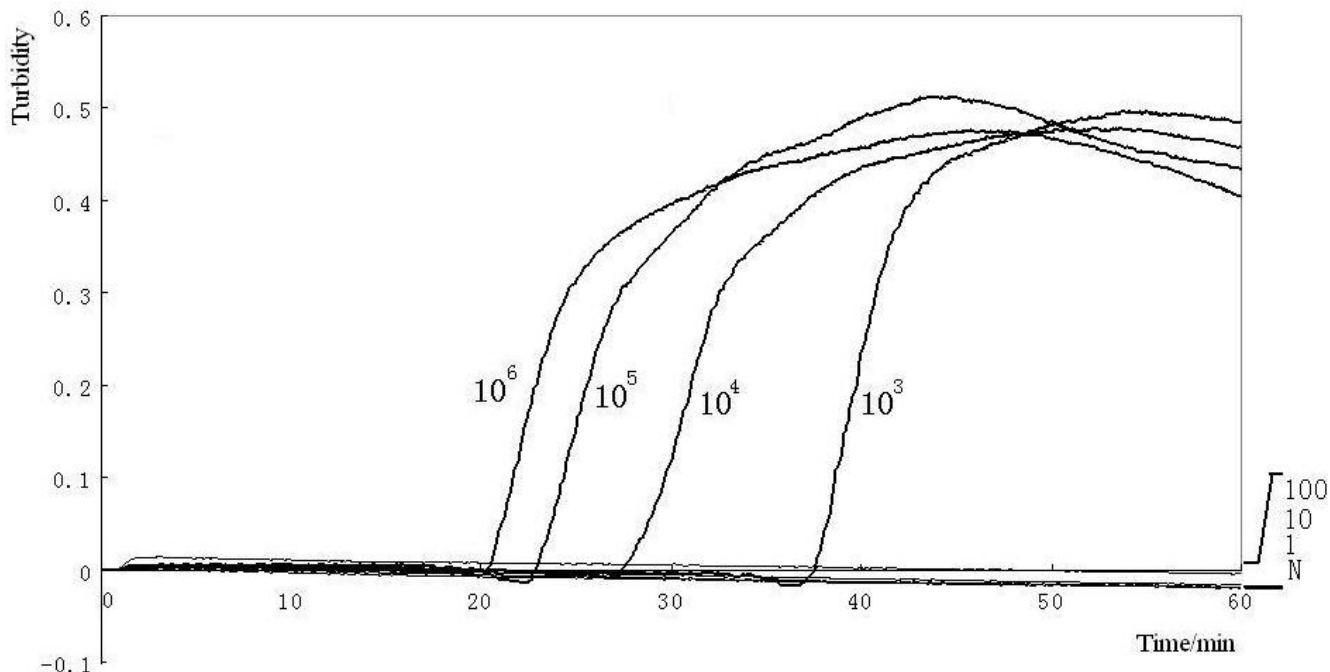

Figure 3. Sensitivity of the RT-LAMP reaction incubated in Loopamp real-time turbidimeter (LA-200). The template arranging from 10^6 to 1 copies per reaction were used. Only the reaction using 10^6 , 10^5 , 10^4 and 10^3 copies could show the positive cure. N, Negative control.

Table 1. Assays for detecting PRRSV clinical samples.

Animal number**	LAMP for classical PRRSV*			LAMP for variant PRRSV		
	1	2	3	1	2	3
Lymph node	+	+	+	+	-	-
Kidney	+	+	+	-	+	+
Spleen	+	+	+	-	-	+
Lung	+	+	+	+	-	+
Liver	-	+	+	-	-	+

*Quoting our previous published method; **every sample had been tested using both assays to detect the classical PRRSV or the highly virulent strains.

HNB is known as a metal indicator for calcium and a colorimetric reagent of alkaline earth metal ions. In a LAMP reaction mixture, dNTPs could influence the colour of HNB by the chelation of Mg^{2+} ions, so that the colour gradually changes from violet to sky blue following the decrease of dNTPs during the amplification process (Goto et al., 2009). In this study, 150 mM HNB had been successfully used to distinguish the positive samples from the negative ones without impact on the efficiency of the developed LAMP-based assay (Figure 2). As compared to other visible endpoint detection method such as visualization of turbidity (Nowotny et al., 1994), addition of DNA intercalating dyes (Hill et al., 2008) and usage of calcein (Tomita et al., 2008), HNB provides a more simple way to achieve the judgments of the reaction product (Goto et al., 2009; Wastling et al., 2010). They

can be added before incubation so that amplification is completed in a closed tube system, it is very easy to identify the colour changes without any other equipment and they are inexpensive.

More also, in comparison with other published method (Chen et al., 2009); the possible reason for the RT-LAMP with a higher detection limit is the difficulty of primer-designing specifically for the particular finite region, which contains the mutation in the variant PRRSV viral genome. However, the successful performance of RT-LAMP assay in this study showed its potential capability of detection of the highly virulent PRRSV in samples of internal tissues and organs of pigs.

In summary, we have successfully demonstrated the high efficiency and specificity of the RT-LAMP method directly detecting the highly virulent PRRSV in clinical

samples. This LAMP-based assay completed under isothermal conditions with simple heating instruments, therefore, has the great potentiality to be used in the field for the detection of the highly virulent PRRSV rapidly.

ACKNOWLEDGEMENT

This work was supported by the Science and Technology Project from Veterinary Bureau, Ministry of Agriculture of the People's Republic of China.

REFERENCES

- Albina E (1997). Epidemiology of porcine reproductive and respiratory syndrome (PRRS): an overview. *Vet. Microbiol.* 55(1-4): 309-316.
- Bautista EM, Goyal SM, Collins JE (1993). Serologic survey for Lelystad and VR-2332 strains of porcine respiratory and reproductive syndrome (PRRS) virus in US swine herds. *J. Vet. Diagn. Invest.* 5(4): 612-614.
- Benfield DA, Nelson E, Collins JE, Harris L, Goyal SM, Bobinson D, Christianson TT, Morrison RB, Gorcyca D, Chladek D (1992). Characterization of swine infertility and respiratory syndrome (SIRS) virus (isolate ATCC VR2332). *J. Vet. Diagn Invest.* 4: 127-133.
- Chen NH, Chen XZ, Hu DM, Yu XL, Wang LL, Han W, Wu JJ, Cao Z, Wang CB, Zhang Q, Wang BY, Tian KG (2009). Rapid differential detection of classical and highly pathogenic North American Porcine Reproductive and Respiratory Syndrome virus in China by a duplex real-time RT-PCR. *J. Virol. Methods*, 161(2): 192-198.
- Goto M, Honda E, Ogura A, Nomoto A, Hanaki K (2009). Colorimetric detection of loop-mediated isothermal amplification reaction by using hydroxy naphthol blue. *Biotechniques*, 46(3): 167-172.
- Guo HC, Xi J, Li JN, Tu CC (2010). Development of Oligonucleotide Microarray Assay for Differentiation of Nsp2-deleted Mutant of Highly Pathogenic PRRSV and Classical American PRRSV Strain. *Chin J. Biologicals*, 23(11): p. 6.
- Hao XF, Zhou YJ, Tian ZJ, Wei TC, An TQ, Peng JM, Hua RH, Tong GZ (2007). Development of a RT-PCR method for differentiation of the highly pathogenic PRRSVs and the classical PRRSVs. *J. Pre. Vet. Med.* 29(9): p. 6.
- Hill J, Beriwal S, Chandra I, Paul VK, Kapil A, Singh T, Wadowsky RM, Singh V, Goyal A, Jahnukainen T, Johnson JR, Tarr PI, Vats A (2008). Loop-mediated isothermal amplification assay for rapid detection of common strains of *Escherichia coli*. *J. Clin. Microbiol.* 46(8): 2800-2804.
- Meulenberg JJ, Hulst MM, de Meijer EJ, Moonen PL, den Besten A, de Kluyver EP, Wensvoort G, Moormann RJ (1993). Lelystad virus, the causative agent of porcine epidemic abortion and respiratory syndrome (PEARS), is related to LDV and EAV. *Virology*, 192(1): 62-72.
- Notomi T, Okayama H, Masubuchi H, Yonekawa T, Watanabe K, Amino N, Hase T (2000). Loop-mediated isothermal amplification of DNA. *Nucleic Acids Res.* 28(12): E63.
- Nowotny N, Mostl K, Maderbacher R, Odorfer G, Schuh M (1994). Serological studies in Austrian fattening pigs with respiratory disorders. *Acta Vet. Hung* 42(2-3): 377-379.
- Rosow KD (1998). Porcine reproductive and respiratory syndrome. *Vet. Pathol.* 35(1): 1-20.
- Stevenson GW, Van Alstine WG, Kanitz CL, Keffaber KK (1993). Endemic porcine reproductive and respiratory syndrome virus infection of nursery pigs in two swine herds without current reproductive failure. *J. Vet. Diagn. Invest.* 5(3): 432-434.
- Tian K, Yu X, Zhao T, Feng Y, Cao Z, Wang C, Hu Y, Chen X, Hu D, Tian X, Liu D, Zhang S, Deng X, Ding Y, Yang L, Zhang Y, Xiao H, Qiao M, Wang B, Hou L, Wang X, Yang X, Kang L, Sun M, Jin P, Wang S, Kitamura Y, Yan J, Gao GF (2007). Emergence of fatal PRRSV variants: unparalleled outbreaks of atypical PRRS in China and molecular dissection of the unique hallmark. *PLoS ONE*, 2(6): e526.
- Tomita N, Mori Y, Kanda H, Notomi T (2008). Loop-mediated isothermal amplification (LAMP) of gene sequences and simple visual detection of products. *Nat. Protoc.* 3(5): 877-882.
- Wastling SL, Picozzi K, Kakembo AS, Welburn SC (2010). LAMP for human African trypanosomiasis: a comparative study of detection formats. *PLoS Negl. Trop. Dis.* 4(11): e865.
- Xiao XL, Wu H, Yu YG, Cheng BZ, Yang XQ, Chen G, Liu DM, Li XF (2008). Rapid detection of a highly virulent Chinese-type isolate of Porcine Reproductive and Respiratory Syndrome virus by real-time reverse transcriptase PCR. *J. Virol. Methods* 149(1): 49-55.
- Zhang YW, Li XN, Guo PP, Fu P, Li JH, Huang SL, Jiang F, Wu WX (2010). Fluorescent reagent in detection of porcine reproductive and respiratory syndrome virus by loop-mediated isothermal amplification (LAMP). *J. Agric. Biotechnol.* 18(3): p. 6.