

Full Length Research Paper

Rapid genetic transformation of sweetpotato (*Ipomoea batatas* (L.) Lam) via organogenesis

H. R. LUO^{1,2}, M. SANTA MARIA^{1‡}, J. BENAVIDES¹, D. P. ZHANG^{1†}, Y. Z. ZHANG² and M. GHISLAIN^{1*}

¹Applied Biotechnology Laboratory, International Potato Center, P.O. Box 1558, Lima 12, Peru.

²College of life sciences, Sichuan University, Chengdu 610064, China.

Accepted 8 September, 2006

An efficient and rapid *Agrobacterium*-mediated transformation method based on de novo (via callus) organogenesis has been developed from petioles with leaf for sweetpotato (*Ipomoea batatas* (L.) Lam). Stable transgenic sweetpotato plants cv. Jewel were obtained in six to ten weeks after infection with *Agrobacterium tumefaciens* hyper-virulent strain EHA105 harboring a binary vector pCIP45 bearing the *nptII* gene conferring resistance to kanamycin and a gene of interest. PCR and Southern analyses confirmed stable integration of both genes into the sweetpotato genome. The expression of the *nptII* gene was assessed by reverse-transcribed PCR and callus development in a high kanamycin medium. A two-step organogenesis regeneration using media containing 4-fluorophenoxyacetic acid (4-FA) and zeatin was used in two independent transformation experiments yielding 20% and 10% transformation efficiency, respectively. When using indolacetic acid (IAA) in regeneration media, the transformation efficiency dropped to 4.0%. It indicated an auxin to cytokinin treatment could improve the regeneration of transgenic calluses. This rapid organogenesis-based transformation strategy represents an important improvement over existing methods and will facilitate producing large-scale transgenic sweetpotato plants the genetic improvement of a crop that is reputed to be difficult to transform.

Key words: *Agrobacterium*-mediated transformation, EHA105, organogenesis, sweetpotato, transgenic plant.

INTRODUCTION

Sweetpotato (*Ipomoea batatas* (L.) Lam) is grown in more than 100 countries as a valuable source of food, animal feed and industrial raw material. Approximately 98.5% of the world's annual output is produced in developing countries, in Asia and sub Saharan Africa (data from FAOSTAT). Sweetpotato plays an important role in household food security in the eastern African countries where small-scale farmers, mainly women grow sweetpotato. Average yields at farmer's fields are as low as 5 tons per hectare, in comparison with the world's average of 15 tons per hectare. The low yield is partly due to the widespread pests and diseases such as swe-

etpotato weevils (*Cylas puncticollis* and *C. brunneus*) and sweetpotato virus diseases (SPVD). The development of host resistance to sweetpotato weevils and SPVD is a high priority for sweetpotato breeding in sub Saharan Africa. Sweetpotato improvement through conventional breeding is time consuming because the need to combine the resistances with desirable yield and post-harvesting qualities. Moreover, resistance to sweetpotato weevil and SPVD has not been found in cultivated sweetpotato gene pool which is accessible by direct sexual hybridization.

The introduction of foreign genes into plants through genetic transformation is a highly promising alternative to conventional breeding. Among different strategies for gene transfer, the use of an *Agrobacterium*-mediated transformation system remains the favorite, as it does not involve sophisticated equipment and produces more frequently clean events (intact integrations and single copy) than particle gun bombardment (Hansen et al., 1997). This last feature of the *Agrobacterium*-mediated process is of utmost importance for clonally propagated

*Corresponding authors E-mail: m.ghislain@cgiar.org. Phone: 51 1 349 6017 / Fax: 51 1 317 5326.

†Present address: USDA ARS, PSI, SPCL, 10300 Baltimore Avenue, BARC-W, Beltsville, MD 20705, USA. OR Horticultural Science Department Box 7609, North Carolina State University, Raleigh NC 27695, USA..

crops such as sweetpotato because the primary transformation event is after thorough characterization the final transformed variety. This explains the lack of adoption of the particle bombardment protocol of genetic transformation developed for the sweetpotato crop (Prakash and Varadarajan, 1992).

The first successful transformation protocol leading to the production of transformed sweetpotato plants was based on the formation of hairy roots using leaf discs as explants by *Agrobacterium rhizogenes* (Dodds et al., 1991; Otani, 1993). However, the regenerated transgenic plants presented morphological abnormalities, such as small storage roots and shorter internodes. Fortunately, *Agrobacterium tumefaciens*-mediated transformation system has been developing via somatic embryogenesis regeneration using either induced non-zygotic (somatic) embryos or organs as explants in last decade by researchers (Newell et al., 1995; Gama et al., 1996; Otani et al., 1998). Some agronomic important genes also have been introduced into sweetpotato for weevils or virus-resistant (Newell et al., 1995; Zhang et al., 2000; Okada et al., 2001) and for nutritive enhancement (Wakita, et al., 2001; Kimura et al., 2001). However, these systems, limited to some cultivars, are relatively slow and laborious because it relies on the establishment of somatic embryogenic calli. Our laboratory has successfully developed *Agrobacterium*-mediated genetic transformation system of sweetpotato via somatic embryogenesis using petioles with leaves as explants for the varieties Jewel, Huachano and Jonathan with genes conferring partial resistance to weevils and viruses (Zhang et al., 2000). However, some sweetpotato cultivars were recalcitrant and hardly regenerated transformed shoots from calluses, including a few important African and Chinese varieties.

Organogenesis-mediated transformation has been developed with limited success so far. Leaf discs were transformed using the strain C58C1 and transgenic plants carrying a *Bacillus thuringiensis* delta-endotoxin gene were obtained through direct organogenesis regeneration (Morán et al., 1998). Stem and leaf explants were also used to generate transformed plants of cv. Jewel (García et al., 2000). Although these authors report that best results were observed with petioles with leaves compared with explants from stems or leaves, no quantitative data were provided. Recently, an organogenesis protocol was developed using leaf disks and petioles including a two-step selection method (kanamycin and hygromycin) lasted for in 12 to 26 weeks with 11.2% and 10.7% transformation efficiency, respectively (Song et al., 2004). But it requires the introduction of two selectable marker genes which complicates gene constructs and increases future biosafety testing. Hence, an efficient and practicable transformation method of sweetpotato was still expected for the production of transgenic sweetpotato plants to meet the requirements of effective genetic improvement of this crop. In this paper, we reported a rapid and reproducible method of *A. tu-*

meffaciens-mediated transformation via shoot organogenesis regeneration and a simple procedure for large-scale screen of numerous putative transformed events.

MATERIALS AND METHODS

Plant materials

Sweetpotato cultivar 'Jewel', a popular variety in the United States, was used in this study. In vitro plants were cultured on propagation medium (MPB: MS salts with minimal organics (Gibco BRL) 4.6 g/L, sucrose 30 g/L, ascorbic acid 0.2 g/L, arginine 0.1g/L, 1,4-diaminobutane 0.02 g/L, gibberellic acid 0.01 mg/L, calcium pantothenate 2 mg/L and agar Phytigel (Sigma) 3 g/L, pH 5.8) and grown for 5-6 weeks in an incubation room at 25-27°C, 16 h photoperiod, 70% relative humidity and 3,000 lux light intensity. Leaves with petiole of about 1 to 1.5 cm were cut from the top third of the plantlets and used as explants in all transformation experiences. Stem internodes and leaf discs were also produced for comparison with leaves with petiole explants.

Bacterial strains and plasmids

Agrobacterium tumefaciens hypervirulent strain EHA105 (Hood et al., 1993) harboring the plant transformation vector pCIP45 was used to infect sweetpotato leaf with petiole explants. The binary vector pCIP45 is a pBIN20 derivative (Hennegan and Danna, 1998). It contains the *nptII* selectable marker gene under the nopaline synthase 'nos' promoter towards the right border of the T-DNA and a gene of interest, *dhdps-r1*, coding for a lysine insensitive mutant of the tobacco *dhdps* gene (Ghislain et al., 1995) cloned into the EcoRI site towards the left border (Figure 1).

Genetic transformation

A single bacterial colony of the *A. tumefaciens* strain EHA105 harboring pCIP45 was used to inoculate 5 ml of standard LB liquid media with kanamycin at 100 mg/L and rifampicin at 100 mg/L in a water bath shaker (200 rpm) at 28°C for overnight growth. A 100 μ l aliquot of this overnight bacterial culture was transferred into a 250 ml Erlenmeyer flask with 50 ml LB media with kanamycin and rifampicin in a water bath shaker (200 rpm) at 28°C until the optical density of culture reaches 0.4 – 0.6 at λ 600 nm. Bacterial cells were centrifuged at 3,000 rpm for 10 min at 4°C and resuspended in same volume of bacterial infection media (MIB: MS salts with minimal organics (Gibco BRL) 4.6 g/L, sucrose 30 g/L, acetosyringone 20 mg/L, and either inodolacetic acid (IAA) 0.5 mg/L or 4-fluorophenoxyacetic acid (4-FA) 0.2 mg/L, adjusted to pH 5.5). Leaf with petioles were submerged in 10 ml of MIB with the strain EHA105 harbouring the binary vector pCIP45 and kept for 24 h in the dark at 25- 27°C without agitation. Following this co-culture step, the explants were blotted onto sterile filter paper and then transferred onto selective regeneration media (MS with minimal organics (Gibco BRL) 4.6 g/L, sucrose 30 g/L, agar Phytigel (Sigma) 3 g/L, cefotaxime 200 mg/L, kanamycin 50 mg/L, and either of IAA 0.5 mg/L (MO-IAA medium) or 4-FA 0.2 mg/L (MO-4FA medium), adjusted to pH 5.8). One of the two regeneration procedures used is a two-hormone protocol in which the explants are first kept on a medium containing 4-FA for 5-6 days and then transferred to a medium containing zeatin (an auxin to cytokinin treatment). Therefore, the infected explants on MO-4FA medium

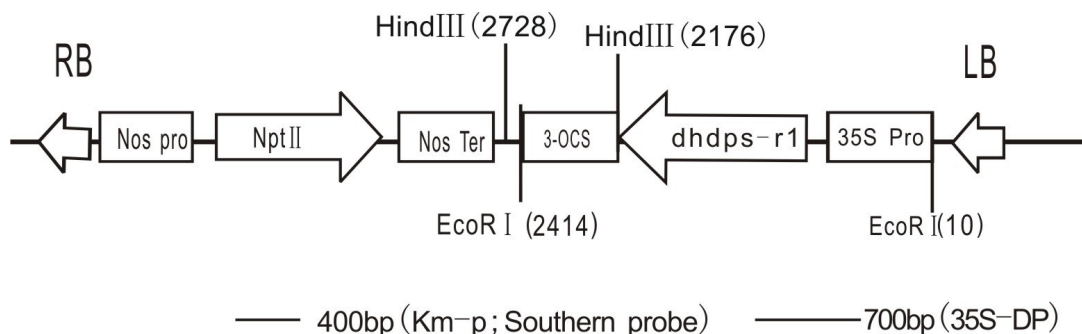

Figure 1. Schematic representation of pCIP45 construct used to agro-infect petioles with leaves of sweetpotato cv. Jewel. LB, left border; RB, right border; Nos pro, nopaline synthase promoter; NptII, neomycin phosphotransferase II; Nos ter, nopaline synthase gene terminator; 35S Pro, cauliflower mosaic virus 35S promoter; dhdps-r1, coding sequence for a lysine insensitive mutant of the tobacco *dhdps* gene; 3-OCS, octopine synthase terminator. Km-P, PCR primer for amplifying a 400bp fragment of *NptII* and probing in southern blot; 35S-DP, PCR primer for amplifying the part of *dhdps-r1* gene and 35S promoter.

were transferred after 5-6 days to the same selective medium containing zeatin 0.2 mg/L (MO-Zea medium) instead of 4-FA. The infected explants were kept in the selective regeneration medium for 6 weeks, changing to fresh medium weekly. Regenerating shoots were harvested and transferred to sweetpotato propagation medium (MPB) with cefotaxime 200 mg/L. The transformation efficiency was calculated as the number of stable transgenic lines obtained over the total number of explants infected. Morphological characterization of the transgenic plants obtained was performed in the greenhouse.

Screening of putative transformed regenerants

Putative transformed shoots were retested for kanamycin resistance (*nptII* gene expression) using a protocol established for potato transformation (A. Reynaerts pers. comm.). Leaf segments were transferred onto callus inducing media (303 medium: D-mannitol 20 g/L, dextrose 20 g/L, nicotinic acid 0.5 mg/L, pyridoxine 0.5 mg/L, glycine 2 mg/L, 2-(N-morpholino)ethanesulfonic acid (MES) 0.5 g/L, polyvinylpyrrolidone (40,000) 0.5 g/L, L-glutamine 200 mg/L, adenine 40 mg/L, naphthalene acetic acid (NAA) 0.1 mg/L, agar Phytigel (Sigma) 3 g/L and adjusted to pH 5.8) containing 100 mg/L kanamycin. Each Petri dish contained a negative control (leaf segment from an untransformed cv. Jewel plant) and a positive control (leaf segment from a transformed cv. Jewel plant obtained previously). These dishes were incubated in a growth chamber at 25-27°C for 16 h photoperiod at 3,000 lux light intensity.

Detection of transformed events by PCR analysis

Rapid detection of transformants was done by PCR analysis. Primer pair Km-P amplified a 400 bp fragment of the *nptII* gene: forward primer 5'-CCGGCTACCTGCCCATTTG-3' and reverse primer 5'-GCGATAGAAGGCGATGCG-3'. PCR reaction was performed in 20 µl volume containing 100 ng of total plant DNA made as follows: 2 µl of 10X Buffer; 0.5 µl from each 10 µM primer solutions, 0.4 µl of 10 mM dNTP; 0.1 µl of Taq polymerase (1unit; Gibco-BRL), and adjusted to 20 µl with Milli-Q distilled water. The PCR amplification cycles were as follows: 96°C for 45sec, 55°C for 45sec, and 72°C for 45sec. This cycle was repeated 35 times and ended up with an elongation step at 72°C for 10min. Visualization of PCR products were done on standard 1% agarose gel electrophoresis using 10 µl of the PCR reaction.

Transgene insertion analyzed by Southern blot hybridization

DNA was extracted from fresh leaf tissue following standard DNA protocols (International Potato Center, 1999). Total plant DNA (10 µg) was digested with *EcoRI* (20 units) or *HindIII* in a 100 µl reaction and incubated at 37°C for at least 4 h to overnight. DNA fragments were separated on a standard 1% agarose gel electrophoresis overnight and then transferred to Amersham Hybond-N nylon membrane. DNA fragments were bound to the membrane by UV-cross linking (Southern Stratalinker 2400). The probe was developed by PCR amplification of a fragment of the *nptII* gene with the pB1121 plasmid as template using standard PCR amplification conditions and an annealing T° of 60°C. This fragment was then labelled with [α -32p]dCTP by Rediprime™ random priming labelling system (Amersham). The membranes were washed using stringent conditions and exposed one week at -70°C to X-ray film (Kodak).

Gene expression by reverse transcribed PCR

Total RNA isolation was extracted using TRIzol reagent (Gibco-BRL). RNase-Free DNase (RQ1 from Promega) was used to remove any contaminating DNA from the RNA preparations. Reverse transcribed (RT) PCR was performed using ImProm-II™ Reverse Transcription System (Promega) following the manufacturer's protocol. The primer pair Km-P was used following the same PCR cycling program described above.

RESULTS

Agro-infection with a hypervirulent strain

The use of a hypervirulent strain of *A. tumefaciens* and an appropriate medium for optimum infection of the plant tissue are critical for a high efficiency transformation protocol. The super virulent Ti plasmid pTiBo542 (Hood et al., 1986) in the *Agrobacterium* strain EH105 is responsible for their high infection potential and has been reported to be very efficient for the genetic transformation of different cultivars (Gama et al., 1996; Otani et al., 1998; Song et al., 2004). Activation of the virulence genes in the Ti plasmid is modulated by molecular sign-

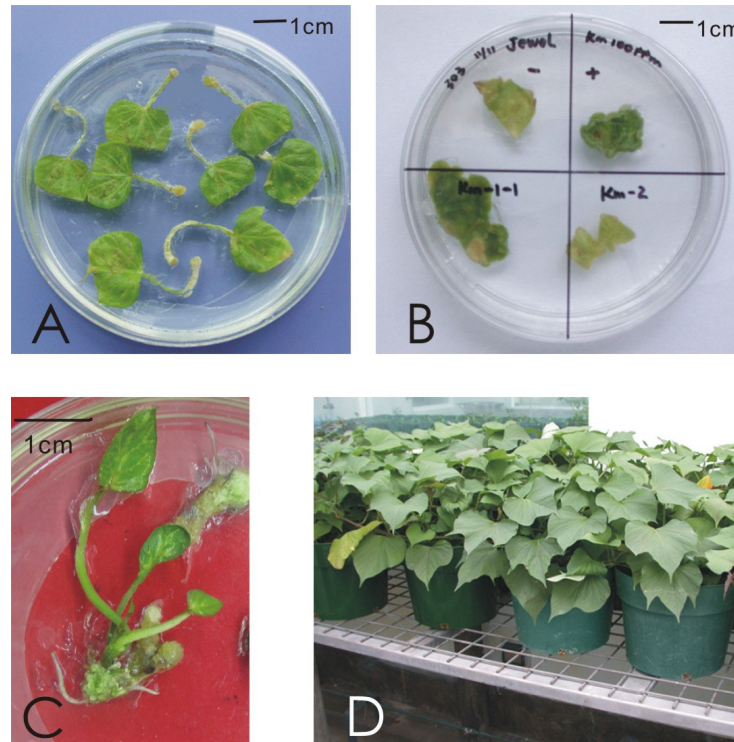

Figure 2. Transformation and regeneration sweetpotato cv. Jewel plants: (A) callus induction from explants 5 days after co-cultivation with *A. tumefaciens* EHA105 in selective MO-4FA medium; (B) Callus formation in transgenic lines (leaf segments) after 4 weeks in high kanamycin 303 medium; (C) *de novo* organogenesis regeneration (shoots) from callus after 4 weeks; (D) morphological characterization of transgenic lines in the greenhouse.

nals provided by wounded tissues. This is mimicked *in vitro* by the addition of phenolic compounds such as acetosyringone (AS) to the co-culture medium. AS concentration commonly used for sweetpotato varies between 10 and 40 mg/L. Using 20 mg/L in our protocol gave satisfactory results. The enrichment of the medium with sugars and a low-pH was reported to improve transformation efficiency of rice and maize (Hiei et al., 1994; Ishida et al., 1996). Our results did not coincide with this observation. We used a co-culture medium with 20 g/L sucrose and no difference were observed when this concentration was increased to 30g/l confirming previous published observations (De la Riva et al., 1998). An overnight incubation with the hypervirulent strain EHA105 did not result in visible necrosis of wounded areas whereas a prolonged exposure for 2 or 3 days did, as observed by García et al. (2000).

Organogenesis regeneration of putative transformed events

Shoots developed after 5 to 6 weeks from the wounded petioles on the selective regeneration medium (Figure 2A and C). The two-hormone protocol (auxin to cytokinin treatment) presented higher regeneration efficiencies than the IAA regime (Table 1). Multiple shoots were

observed sometimes from the same callus but turned out to be identical transformation events. The initial short callus inducing step on 4-FA medium in the two-hormone protocol seems to be needed compared to direct organogenesis for producing transgenic events with less false positives. This 4-FA step seems to favor better recovery and selection for the rare transformed cells. Such observation has been reported for cottonwood hybrids (Han et al., 2000). All the transgenic lines had normal phenotypes in greenhouse observations (Figure 2D). When Leaf discs were used for transformation, resistant callus with a compact structure was produced which rarely regenerated shoots. Similar observations were reported when using storage root discs as explants (Newell et al., 1995). All tested 60 stem internodes did regenerate shoots and roots already one to two weeks after the agroinfection but none were transformed.

Screening for true transformed events

The use of high concentration of kanamycin at 100 mg/L for retesting putative transformed events gave unambiguous results. After 3 to 4 weeks on 303 medium with 100 mg/L kanamycin, true transformed plants produced green calli similar to the positive control (Figure 2B) while the untransformed leaf discs turned yellow and failed to

Table 1. Transformation efficiency of leaf petioles via *de novo* organogenesis from three independent transformation experiments in sweetpotato (Cv. Jewel).

Transformation No.	Selective regeneration medium	Explants infected	Regenerated shoots	Kanamycin resistant test positive	PCR positive	Southern blot positive	Transformation efficiency (%)
I	IAA	75	3	3	3	3	4
II	4FA-Zeatin	35	19	7	7	7	20
III	4FA-Zeatin	50	35	5	5	5	10

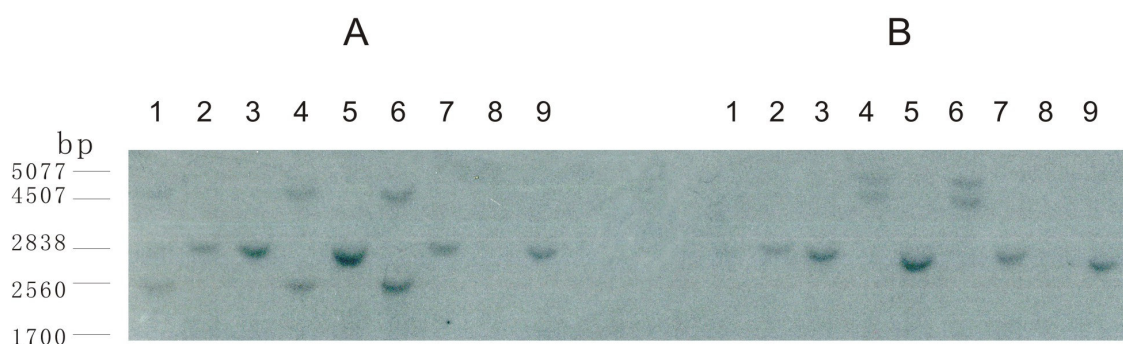

Figure 3. Southern hybridization analysis of transgenic sweetpotato lines for determination of the number of copies. Molecular weight are indicated based on electrophoretic mobility of λ DNA (Gibco-BRL) digested with *Pst*I; Hybridization is obtained with a fragment of the *nptII* gene as the probe. Plant DNA digested by A with *Hind*III and B with *Eco*RI. Lane 1- 7: putative transgenic sweetpotato lines; lane 8 : an untransformed line; lane 9 :the *nptII* gene as positive control.

form callus. This screening allowed us to identify the 15 transgenic events out of the 57 that regenerated. The large number of false positives makes this kanamycin-resistance assay a necessary step prior doing time-consuming and costly molecular and phenotypic characterizations of the transformed plants.

Molecular evidence for genetic transformation

The expected 400 bp and 700 bp fragments obtained with the Km-P and 35S-DP primer pairs (Figure 1) were observed in all putative transformed events that passed the screening for kanamycin resistance (Table 1). The percentage of PCR positive plants proved to be 20% and 10% transformation efficiency in 4-FA-Zeatin selective strategy, with an average of 15%. When using indolacetic acid (IAA) in regeneration media, the transformation efficiency dropped to 4.0% (Table 1).

The Southern blot hybridization is obtained with a fragment of the *nptII* gene as the probe. All kanamycin resistant plants were tested by Southern blotting and displayed a distinct pattern of hybridizing bands with *Hind*III and *Eco*RI restriction (Figure 3). The low number of bands observed per line indicates that single or double copy of the T DNA was integrated. No signal was detected in the genomic DNA from the untransformed line.

Expression of the *nptII* gene

The characterization of *nptII* gene expression was done by RT-PCR because of the sensitivity and easiness of this method. The expression of the *nptII* gene was detected and measured in transgenic plants (Figure not shown). All the Southern blot positive plants yielded the expected 400 bp fragment (Figure 1), indicating expression of the inserted *nptII* gene conferring kanamycin resistance. The absence of genomic DNA contamination was confirmed by a parallel PCR amplification using 35S-DP primer pair encompassing the promoter and coding sequence from the gene of interest.

DISCUSSION

With the exception of the dip-flower method for *Arabidopsis thaliana*, genetic transformation requires an efficient method to regenerate shoots from *in vitro* tissue culture. Various sources of explants have been the target tissues for transformation of sweetpotato. Leaf discs have been widely used for the genetic transformation of other plants; however, there are few reports using leaf discs as explants for sweetpotato (Newell et al., 1995; Morán et al., 1998). The later group reported the use of stem and leaf explants in their later work (García et al., 2000).

These authors obtained a regeneration efficiency of kanamycin resistant shoots of 33%, however, the true transformation efficiency (based on Southern blot analysis) was not clearly provided. Although regeneration from stem explants was relatively rapid (12-16 weeks) and yielded high transformation frequencies (30.8%) (Song et al., 2004), untransformed escapes of all regeneration plantlets were observed in our hands. The strong regeneration capacity of this tissue seems to compete with the regeneration from the rare transformed cells. This different response of stem explants is possibly due to the selection with hygromycin in Song's work. The cells of sweetpotato were reported by them to be more sensitive to hygromycin than to kanamycin. Overall, our results with sweetpotato cv. Jewel indicate that the best source of explants for genetic transformation of sweetpotato is leaf with petiole of 5- to 6-week old.

Key to an efficient selection of putative transformed events is the screening on 303 medium with 100 mg/L kanamycin. This step proved to be a very reliable method to eliminate any false positives prior to molecular characterizations. This selection strategy is more practicable and simple than two-step selection (kanamycin-hygromycin) for it requires the introduction of two selectable marker genes which complicates gene constructs and increases future biosafety testing (Song et al., 2004). RT-PCR is another useful technique for screening the expression of transgenes in the putative transgenic lines at an early stage of propagation.

In this report, an efficient, rapid and reproducible method for the genetic transformation of sweetpotato cv. Jewel was developed using a hypervirulent strain of *Agrobacterium tumefaciens* via de novo organogenesis. Transformation efficiencies of up to 20% were higher than those reported before for sweetpotato (Newell et al. 1995, Otani et al. 1998; Morán et al., 1998). Transgenic plants were obtained after only 6-10 weeks from infection with *Agrobacterium* with one selectable marker gene instead of two in 18 to 26 weeks as reported previously (Song et al., 2004). In comparison with prolonged regeneration steps required in the somatic embryogenesis protocols (Newell et al. 1995; Otani et al. 1998; Zhang et al., 2000), the rapid de novo organogenesis is likely to lower somaclonal variations.

This protocol is currently being optimized for African sweetpotato cv. Tanzania with respect to the co-culture (bacterial concentration) and regeneration steps (combination of auxin and cytokinin). This rapid transformation method could produce large-scale of transgenic plants of some elite cultivars of sweetpotato, especially of Africa.

ACKNOWLEDGEMENTS

This work was supported by the grant 2002 FS 058 "Building consumer confidence in Genetically Modified Food Crops" of the Rockefeller Foundation. The authors are grateful their CIP colleagues Dr. Jan Kreuze, Jose

Condori and Luis Ñopo for their constant support and help in the lab work, and to Dr. Elizabeth Hood (Prodigene, USA) for providing us the *Agrobacterium tumefaciens* strain EHA105.

REFERENCES

- De la Riva GA, González-Cabrera J, Vázquez-Padrón R, Ayra-Pardo C (1998). *Agrobacterium tumefaciens*: a natural tool for plant transformation. *Electronic J. Biotechnol.* 1: 1-16
- Dodds, JH, Merzdorf C, Zambrano V, Sigüenías C, Jaynes J (1991). Potential use of *agrobacterium*-mediated gene transfer to confer insect resistance in sweetpotato. In: Sweetpotato pest management: a global perspective, Richard K. Jansson, Kandukuri V. Raman, eds, West view Press, Oxford, U.K., pp 203-219
- Gama MIC, Leite JRP, Cordeiro AR, Cantliffe DJ. (1996). Transgenic sweetpotato plants obtained by *Agrobacterium tumefaciens* mediated transformation. *Plant Cell Tissue and Organ Culture* 46: 237-244
- García R, Morán R, Mena J, Somontes D, Zaldúa Z, López A, García M (2000). Sweetpotato (*Ipomoea batatas* L.) regeneration and transformation technology to provide weevil (*Cylas formicarius*) resistance. Field trial results. In: Plant Genetic Engineering: Towards the Third Millennium. A. D. Arencibia (Editors). 2000 Elsevier Science B.V. pp112-117
- Ghislain M, Frankard V, Jacobs M. (1995). A dinucleotide mutation in dihydrodipicolinate synthase of *Nicotiana glauca* leads to lysine overproduction. *Plant J.* 8(5):733-743
- Han KH, Meilan R, Ma C, Strauss SH (2000). An *Agrobacterium tumefaciens* transformation protocol effective on a variety of cottonwood hybrids (genus *Populus*). *Plant Cell Reports*.19: 315-320
- Hansen G, Shillito RD and Chilton MD (1997). T-strand integration in maize protoplasts after codelivery of a T-DNA substrate and virulence genes. *Proceeding of the National Academy of Sciences USA* 94:11726-11730
- Hennegan KP, Danna KJ (1998). pBIN20: an improved binary vector for *Agrobacterium*-mediated transformation. *Plant Molecular Biology reporter* 16: 129-131
- Hiei Y, Ohta S, Komari T, Kumashiro T (1994). Efficient transformation of rice (*Oryza sativa*) mediated by *Agrobacterium* and sequence analysis of the boundaries of the T-DNA. *The Plant Journal* 6: 271-282
- Hood EE, Gelvin SB, Melchers LS, Hoekema A (1993). New *Agrobacterium* helper plasmids for gene transfer to plants (EHA105). *Transgenic Research* 2: 208-218
- Hood EE, Helmer GL, Fraley RT, Chilton MD (1986). The hypervirulence of *Agrobacterium tumefaciens* A281 is encoded in a region of pTiBo542 outside of T-DNA. *J. Bacteriol.* 168:1291-1301
- International Potato Center (CIP) 1999. Molecular Biology Laboratory Protocols: Plant Genotyping. Ghislain, M., Zhang, D.P., Herrera, M. del R. (eds.), Training Manual. 2nd Edition, Lima, Peru
- Ishida Y, Saito H, Ohta S, Hiei Y, Komari T, Kumashiro T (1996). Highly efficiency transformation of maize (*Zea mays* L.) mediated by *Agrobacterium tumefaciens*. *Nature biotechnology* 4: 745-750
- Kimura T, Otani M, Noda T, Ideta O, Shimada T, Saito A (2001). Absence of amylose in sweetpotato following the introduction of granule-bound starch synthase I cDNA. *Plant Cell Report* 20: 663-666.
- Morán R, García R, López A, Zaldúa Z, Mena J, García M, Armas R, Somontes D, Rodríguez D, Gómez M, Pimentel E (1998). Transgenic sweetpotato plants carrying the delta-endotoxin gene from *Bacillus thuringiensis* var. *tenebrionis*. *Plant science* 139: 75-184
- Newell C.A, Lowe JM, Merryweather A, Rooke LM, Hamilton WDO (1995). Transformation of sweetpotato (*Ipomoea batatas* (L.) Lam.) with *Agrobacterium tumefaciens* and regeneration of plants expressing cowpea trypsin inhibitor and snowdrop lectin. *Plant Science* 107: 215-227
- Okada Y, Saito A, Nishiguchi M, Kimura T, Mori M, Hanada K, Sakai J, Miyazaki C, Matsuda Y, Murata T (2001). Virus resistance in transgenic sweetpotato (*Ipomoea batatas* (L.) Lam.) expressing the

- coat protein gene of sweetpotato feathery mottle virus. *Theoretical Applied Genetics* 103: 743-751
- Otani M, Mii M, Handa T, Kamada H, Shimada T (1993). Transformation of sweetpotato (*Ipomoea batatas* (L.) Lam.) *Plant Sci.* 94: 151-159
- Otani M, Shimada T, Kimura T, Saito A (1998). Transgenic plant production from embryogenic callus of sweetpotato (*Ipomoea batatas* (L.) Lam.) using *Agrobacterium tumefaciens*. *Plant Biotechnology* 15: 11-16
- Prakash CS, Varadarajan U (1992). Genetic transformation of sweetpotato by particle bombardment. *Plant Cell Report* 11: 53-57
- Song G.-Q, Honda H, Yamaguchi KI (2004). Efficient *Agrobacterium tumefaciens* –mediated transformation of sweetpotato (*Ipomoea batatas* (L.) Lam.) from stem explants using a two-step kanamycin-hygromycin selection method. *In vitro Cell. Dev. Bio.-Plant* 40: 359-365
- Wakita Y, Otani M, Hamada T, Mori M, Iba K (2001). A tobacco microsomal ω -3 fatty acid desaturase gene increases the linolenic acid content in transgenic sweetpotato (*Ipomoea batatas*). *Plant Cell Reports* 20: 244-249
- Zhang D, Cipriani G, Rety I, Golmirzaie A, Smit S, Michaud D (2000). Expression of protease inhibitors in sweetpotato. In: *Recombinant Protease Inhibitors in Plants*. Michaud, D., ed., Landes Bioscience, Georgetown TX, USA, pp. 167-178.