

Review

A bioseparation process for removing heavy metals from waste water using biosorbents

Igwe, J. C.^{1*} and Abia A.A.²

¹Department of Industrial Chemistry, Abia State University, P.M.B. 2000, Uturu, Nigeria.

²Department of Pure and Industrial Chemistry, University of Port-Harcourt, River State, Nigeria.

Accepted 15 May, 2006

The removal of heavy metals from our environment especially wastewater is now shifting from the use of conventional adsorbents to the use of biosorbents. The presence of heavy metals in the environment is of major concern because of their toxicity, bioaccumulating tendency, and threat to human life and the environment. In recent years, many low cost sorbents such as algae, fungi bacteria and lignocellulosic agricultural by-products have been investigated for their biosorption capacity towards heavy metals. In this comprehensive review, the emphasis is on outlining the occurrences and toxicology of heavy metals and the biosorption capacity of biosorbents compared to conventional adsorbents. A detailed description of the adsorption properties and mode of action of these biosorbents is offered in order to explain the heavy metal selectivity displayed by these biosorbents. The role of cell structure, cell wall, micropores and macropores is evaluated in terms of the potential of these biosorbents for metal sequestration. Binding mechanisms are discussed, including the key functional groups involved and the ion-exchange process. Quantification of metal-biomass interactions is fundamental to the evaluation of potential implementation strategies, hence, sorption isotherms, sorption kinetics, intraparticle diffusivities as well as models used to characterize biosorbent sorption are reviewed. The sorption behavior of some biosorbents with various heavy metals is summarized, their relative performance evaluated and a bioseparation process flow diagram for heavy metal removal from wastewater using biosorbents was proposed.

Key words: Biosorption, heavy metals, biosorbents, kinetics, wastewater.

INTRODUCTION

The current pattern of industrial activity alters the natural flow of materials and introduces novel chemicals into the environment (Faisal and Hasnain, 2004). The rate at which effluents are discharged into the environment especially water bodies have been on the increase as a result of urbanization. Most of these effluents contain toxic substances especially heavy metals. The presence of heavy metals in the environment is of major concern because of their toxicity, bio-accumulating tendency, threat to human life and the environment (Horsfall and Spiff, 2005; Igwe and Abia, 2003). Lead, cadmium and mercury are examples of heavy metals that have been

classified as priority pollutants by the U.S Environmental protection Agency (U.S EPA) (Keith et al., 1979).

Heavy metals are among the conservative pollutants that are not subject to bacterial attack or other break down or degradation process and are permanent additions to the marine environment (El-Nady and Atta, 1996). As a result of this, their concentrations often exceed the permissible levels normally found in soil, water ways and sediments. Hence, they find their way up the food pyramid. When they accumulate in the environment and in food chains, they can profoundly disrupt biological processes.

The primary sources of heavy metals pollution in coastal lagoons are input from rivers, sediments and atmosphere, which can affect aquaculture profitability in certain areas (Krishnani et al., 2004). The anthropogenic sources of heavy metals include wastes from the

*Corresponding authors E-mail: jcigwe2001@yahoo.com.

electroplating and metal finishing industries, metallurgical industries, tannery operations, chemical manufacturing, mine drainage, battery manufacturing, leather tanning industries, fertilizer industries, pigment manufacturing industries, leachates from land fills and contaminated ground water from hazardous waste sites (Reed, et al., 1994; Jackson and Alloway, 1991; Huang and Fu, 1984; Mclaughlin et al., 1996; Faisal and Hasnain, 2004). Heavy metals are also emitted from resource recovery plants in relatively high levels on fly ash particles (Neal et al., 1990)

Heavy metal toxicology

Metals can be toxic to microbial population at sufficiently high concentrations. However, some metals such as silver, mercury, cadmium and copper are markedly more toxic even at very low levels (Forstner and Wittman, 1979). Among the toxic heavy metals, mercury, lead and cadmium, "called the big three" are in the limelight due to their major impact on the environment (Volesky, 1994). Arsenic, chromium copper and zinc are also toxic; lead and cadmium are potent neurotoxic metals (Puranik and Pakniker, 1997).

The chemistry and toxicology of these heavy metals are complex and interesting. For example, chromium has both beneficial and detrimental properties. Two stable oxidation states of chromium persist in the environment, Cr(III) and Cr(VI) which have contrasting toxicities, mobility and bioavailability (Saifuddin and Kumaran, 2004). While Cr(III) is relatively innocuous and immobile, Cr(VI) moves readily through soils and aquatic environments and is a strong oxidizing agent capable of being absorbed through the skin (Park and Jung, 2001). Hexavalent chromium, Cr(VI), is the toxic form of chromium released during many industrial processes including electroplating, leather tanning and pigment manufacture (Faisal and Hasnain, 2004). Trivalent chromium, Cr(III), is an essential element required for normal carbohydrate and lipid metabolism (Mertz, 1993; Anderson, 1998). Its deficiency leads to increase in risk factors associated with diabetes and cardiovascular diseases including elevated circulating insulin, glucose, triglycerides, total cholesterol and impaired immune function leading to hemorrhage, respiratory impairment and liver lesions (Rhode and Hartmann, 1980). Contrary to deficiency symptoms, several factors make chromate contamination a matter of intense concern, particularly its toxic, mutagenic (Cheng and Dixon, 1998), carcinogenic (Shumilla et al., 1999), and teratogenic (Asmatullah et al., 1998) effects. Also, Cr(VI) forms stable anions, such as $\text{Cr}_2\text{O}_7^{2-}$, HCrO_4^- , CrO_4^{2-} and HCr_2O_7^- , the fraction of any particular species is dependent upon the chromium concentration and pH (Udaybhaskar et al., 1990), which in turn affects the toxicity and bioavailability.

The sources of human exposure to Cd include atmospheric, terrestrial and aquatic routes (Wolnik et al.

1995; Lopez et al., 1994). The most severe form of Cd toxicity in humans is "itai-itai", a disease characterized by excruciating pain in the bone (Kasuya et al., 1992; Yasuda et al., 1995). Other health implications of Cd in humans include kidney dysfunction, hepatic damage and hypertension (Klaassen, 2001). However, it has been suggested that overall nutritional status (rather than mere Cd content of food) is a more critical factor in determining Cd exposure (Vahter et al., 1996). It has been shown that Zn and Cu competitively inhibit Cd uptake by cells (Endo et al., 1996). The recommended daily intake of Zn is between 4 and 16 mg depending on age, sex and physiological state (FNB, 1974). Zn is an essential element to man, being a cofactor of many enzyme systems (Ukhum et al., 2005). It has been reported to competitively inhibit Pb uptake in cells (Alda and Garay, 1990; Lou et al., 1991). Pb is a heavy metal poison which forms complexes with oxo-groups in enzymes to affect virtually all steps in the process of hemoglobin synthesis and porphyrin metabolism (Ademorati, 1996). Toxic levels of Pb in man have been associated with encephalopathy, seizures and mental retardation (Schumann, 1990).

Copper, one of the most widely used heavy metal, is mainly employed in electrical and electroplating industries, and in larger amounts is extremely toxic to living organisms. The presence of copper (II) ions, cause serious toxicological concerns, it is usually known to deposit in brain, skin, liver, pancreas and myocardium (Davis et al., 2000). Mercury pollution results from metallurgical industries, chemical manufacturing and metal finishing industries (Igwe et al., 2005). Mercury in the liquid form is not dangerous and it is used in a number of industries. In the vapor form mercury becomes very poisonous. It attacks the lungs, kidneys and the brain. The vapor crosses the blood-brain and blood stream. Arsenic affects the skin causing skin cancer in its most severe form. A massive outbreak of arsenical dermatosis, that was reported in some parts of West Bengal State of India, was linked with high levels of arsenic in tube well waters (0.2-2.0 mg/l) (Chakrabarty and Saha, 1987). Arsenic occurs mainly as As(III) and As(V). The oxy-anions of arsenate (V) can exist in four different arsenate species as H_3AsO_4 , H_2AsO_4^- , HAsO_4^{2-} and AsO_4^{3-} in the pH range <2, 3-6, 8-10 and >12, respectively (Sadiq et al., 1983), thus affecting toxicity. Nickel toxicity in man is yet unknown.

Therefore, a complete understanding about noxious effects caused by the release of toxic metals into the environment and the emergence of more severe environmental protection laws, have encouraged studies about removal/recovery of heavy metals from aqueous solutions using bio-sorption.

Adsorption and biosorption processes

Adsorption is the ability of the adsorbate to adhere or

Table 1: Biomass and resin with Metal – binding capacities

Type of biomass	Biosorbent capacity (meq/g)
<i>Sargassum sp.</i>	2-2.3
<i>Ascophyllum sp.</i>	2-2.5
<i>Eclonia radiata</i>	1.8-2.4
<i>Rhizopus arrhizus</i>	1.1
Peat moss	4.5-5.0
Commercial resins	0.35-5.0

Source: Kkratochvil and Volesky (1998).

attach to the adsorbent. It is a well established separation technique to remove dilute pollutants as well as to recover valuable products from aqueous streams. In the conventional adsorption process, the particle size of the adsorbent is restricted because of hydrodynamic phenomena such as pressure drop (Chia-Chang and Hwai-Shen, 2000). Adsorption is divided in two; one is due to forces of physical nature called van der waals force. This adsorption is relatively weak and plays an unimportant part in connection with surface reactions, since they are not sufficiently strong to influence appreciably the reactivity of the molecule adsorbed. The second type is considerably stronger. The adsorbed molecules are held to the surface by valence force of the same type as those occurring between bound atoms in molecules. This is known as chemisorption and the heat evolved is of the order 10 to 100 kcal per mole, compared to physisorption which has less than 5 kcal per mole (Motoyuki, 1990).

Adsorptive removal of heavy metals from aqueous effluents which have received much attention in recent years is usually achieved by using activated carbon or activated alumina (Faust and Aly, 1987; Shim et al., 2001; Ouki et al., 1997; Hsisheng and Chien-To, 1998; Ralph et al., 1999; Ali et al., 1998; Monser and Adhoun, 2002; Igwe et al., 2005). Activated carbon is a porous material with an extremely large surface area and intrinsic adsorption to many chemicals. Polymer resins that can form complexes with the heavy metal ions are the best adsorbents (Lu et al., 1994). These are called conventional adsorbents and many others have been reported such as silica gel, active alumina, zeolite, metal oxides (Motoyuki 1990) and so on. These conventional adsorbents are employed in many processes for the removal of heavy metals from wastewater such as chemical precipitation, chemical oxidation or reduction, electrochemical treatment, evaporative recovery, filtration, reverse osmosis, ion exchange and membrane technologies (Preetha and Viruthagiri 2005; Rengaraj et al., 2001; Yurlova et al., 2002; Benito and Ruiz, 2002). These processes may be ineffective or expensive (Volesky and Holans, 1995) especially when the heavy metal ions are in solutions containing in the order of 1-100 mg dissolved heavy metal ions/L (Volesky 1990a,b). Activated carbon is only able to remove around 30-40

mg/g of Cd, Zn, and Cr in water and is non-regenerable, which is quite costly to wastewater treatment (Gang and Wiexing, 1998). A major draw back with precipitation is sludge production. Ion exchange is considered a better alternative technique, but it is not economically appealing because of high operational cost. As a result of these, biological methods such as biosorption/bioaccumulation for the removal of heavy metal ions may provide an attractive alternative to physico-chemical methods (Kapoor and Viraraghavan, 1995; Pagnanelli et al., 2000).

Biosorption or bioremediations consists of a group of applications which involve the detoxification of hazardous substances instead of transferring them from one medium to another by means of microbes and plants. This process is characterized as less disruptive and can be often carried out on site, eliminating the need to transport the toxic, materials to treatment sites (Gavrilescu, 2004). Biosorbents are prepared from naturally abundant and/or waste biomass. Due to the high uptake capacity and very cost-effective source of the raw material, biosorption is a progression towards a perspective method. Various biomaterials have been examined for their biosorptive properties and different types of biomass have shown levels of metal uptake high enough to warrant further research (Volesky and Holan, 1995). Biosorbents of plant origin are mainly agricultural by-products such as, maize cob and husk (Igwe and Abia, 2003, 2005; Igwe et al., 2005b,c), sunflower stalk (Gang and Weixing, 1998), medicago sativa (Alfalfa) (Gardea-Torresdey et al., 1998), cassava waste (Abia et al., 2003), wild cocoyam (Horsfall and Spiff, 2004, 2005), sphagnum peat moss (Ho et al., 1995), sawdust (Igwe et al., 2005d; Raji and Aniridhan, 1998), chitosan (Ngah and Liang, 1999; Saifuddin and Kumaran, 2005; Wataru and Hiroyuki, 1998), Sago waste (Quek et al., 1998), peanut skins (Randall et al., 1974), shea butter seed husks (Eromosele and Otitolaye, 1994), banana pith (Low et al., 1995), coconut fiber (Igwe et al., 2005e), sugar-beet pulp (Reddad et al., 2003), wheat bran (Dupond and Guillon, 2003), sugarcane bagasse (Krishnani et al., 2004) and so on.

Many other biosorbents of algal, fungal and bacteria biomass have been utilized. These includes among others; bacterial strains (*Pseudomonas ambigua*, *Desulfovibrio vulgaris*, *Enterobacter cloacae* Ho-1, *Alcaligenes eutrophus*, *Dinococcus radiodurans* R1) (Deleo and Ehrlich, 1994; Fedrickson et al., 2000; McLean and Beveridge, 2001; Ioannis and Zouboulis, 2004). Bacteria are widespread, abundant, geochemically reactive components of aquatic environments. Fungal biomass has also been used (Guibal et al., 1992). Table 1 lists some of the species having metal-binding capacity comparable with commercial synthetic cation-exchange resins. Table 2 reports the comparative sorption capacity for copper removal using different biosorbents.

Most studies of biosorption for metal removal have

Table 2: Comparison of copper (II) biosorption by different biosorbents on the basis of maximum uptake capacity (Q_{max})

Biosorbent	Qmax (mg/g)	Source
<i>Desulfovibrio desulfuricans</i>	16.7	Chen et al 2000
<i>Ganoderma Lucidum</i>	24	Muraleedharan et al 1995
<i>Sargassum filipendula</i>	56	Davis et al, 2000
<i>Sargassum fluitans</i>	51	Davis et al ,2000
<i>Sargassum vulgare</i>	59	Deavis et al ,2000
<i>Ulva reticulata</i>	74.63	Vijayaraghavan et al 2005.
Sunflower stalk	29.30	Gang and Welxing, 1998

Table 3: Comparison of Adsorbent capacity of various adsorbents

S/N	Adsorbent	Q _o (mg/g)	source
1.	Hydrous Fe oxide with polyacrylamide	43.0	Shigetomi et al, 1980
2.	Chemvion F. 400 GAC	20.22	Rajakovic and Mitovic, 1972
3.	Cu ²⁺ - impregnated chemviron F-400 GAC	17.23	- do-
4.	Activated alumina	17.61	Ghosh and Yuan, 1987
5.	Y (III) – impregnated alumina	14.45	Wasay et al 1996
6.	Alumina	13.64	- do-
7.	La (III) –impregnated alumina	12.88	-do-
8.	Waste Fe (III)/Cr (III) hydroxide	11.02	Namasivayam and senthilkumar, 1998.
9.	Activated alumina	5.02	Gupta and chen 1978
10.	Activated Bauxite	3.89	- do-
11.	Activated Carbon	1.05	- do-
12.	Activated carbon Darco	3.75	Huong and Fu, 1984
13.	Al ₂ O ₃ /Fe (OH) ₃	0.09	Hodi et al, 1995

involved the use of either laboratory-grown microorganism or biomass generated by the pharmacology and food processing industries or wastewater treatment units (Tsezos and Volesky, 1981; Townsley et al., 1986; Rome and Gadd, 1987; Macaskie, 1990; Costa and Leite, 1991; Rao et al., 1993). Therefore, this promotes environment eco-friendliness. The mechanism by which microorganisms remove metals from solutions are: (i) extracellular accumulation/precipitation; (ii) cell-surface sorption or complexation; and (iii) intracellular accumulation (Muraleedharan et al., 1991). Among these mechanisms, extracellular accumulation/precipitation may be facilitated by using viable microorganisms, cell-surface sorption or complexation can occur with alive or dead microorganisms, while intracellular accumulation requires microbial activity (Asku et al., 1991).

Although living and dead cells are capable of metal accumulation, there are differences in the mechanisms involved, depending on the extent of metabolic dependence (Gadd, 1990). The physiological state of the organism, the age of the cells, the availability of micronutrients during their growth and the environmental

conditions during the biodorption process (such as pH, temperature, and the presence of certain co-ions) are important parameters that affect the performance of a living biosorbent. The efficiency of metal concentration on the biosorbent is also influenced by metal solution chemical features (Volesky, 1990).

For agricultural by-products, the mode of sorption can be attributed to two main terms; intrinsic adsorption and coulombic interaction (Gang and Weixing, 1998). The coulombic term results from the electrostatic energy of interactions between the adsorbents and adsorbates. The charges on both substrates as well as softness or hardness of charge on both sides are mostly responsible for the intensity of the interaction. Coulombic interaction can be observed from the adsorption of cationic species versus anionic species on adsorbents (Gang and Weixing, 1998). The intrinsic adsorption of the materials is determined by their surface areas, which can be observed by the effect of different sizes of adsorbent on adsorption capacity (Igwe and Abia, 2003).

The results obtained with the use of natural biosorbents in the removal of heavy metals from solutions, is shown on Table 3. Also on the same table, we have results from

some conventional adsorbents as a comparison. We see that biosorbents compare favourably with conventional adsorbents. We can explain this by looking at adsorption process reaction mechanism on biosorbents. Sorption is a surface reaction. Most biosorbents contain micropores and adsorption process is affected by surface properties such as surface area and polarity. A large specific surface area is preferable for providing large adsorption capacity, but the creation of a large internal surface area in a limited volume inevitably gives rise to large numbers of small sized pores between adsorption surfaces. The size of micropores determines the accessibility of adsorbate molecules to the adsorption surface. Therefore, the pore size distribution of micropore is an important property for characterizing adsorptivity of adsorbents (Motoyuki, 1990). Also, the existence of macropores, which serve as diffusion paths of adsorbate molecules from outside the granule to the micropores in fine powders and crystals can be used to classify adsorbents. These properties or attributes are possessed both by conventional and non-conventional adsorbents. This explains why they are capable of removing heavy metals from solution. In addition, non-conventional adsorbents contain cellulose which is made up of repeating units of β -D-glucose as a major component of cell walls. The polar hydroxyl groups on the cellulose could be involved in chemical reaction and hence bind heavy metals from solutions. The surface properties of these functional groups on cellulose could be modified by incorporation of other functional groups, and this also affects the adsorption capacity (Igwe et al., 2005c). Chitosan is synthesized from chitin (2-acetamido-2-deoxy-b-D-glucose-(N-acetylglucan), which is the main structural component of mollusks, insects, crustaceans, fungi, algae and marine invertebrates like crabs and shrimps (Deshpande, 1986; Chen and Chang, 1994; Ilyina et al., 1995). Chitosan (2-acetamido-2-deoxy-b-D-glucose-(N-acetylglucosamine) is a partially deacetylated polymer of chitin and is usually prepared from chitin by deacetylation with a strong alkaline solution. The structure also looks very much like that of glucose.

Sorption isotherm studies

In order to estimate practical or dynamic adsorption capacity, however, it is essential first of all to have enough information on adsorption equilibrium. Since adsorption equilibrium is the most fundamental property, a number of studies have been conducted to determine:

1. The amount of species adsorbed under a given set of conditions (concentration and temperature), or
2. How selective adsorption takes place when two or more adsorbable components co-exist. When an adsorbent is in contact with the surrounding fluid of a certain composition, adsorption takes place and after

a sufficiently long time, the adsorbent and the surrounding fluid reach equilibrium. This means that the equilibrium distribution of metal ions between the sorbent and the solution is important in determining the maximum sorption capacity.

Equilibrium studies that give the capacity of the adsorbent and adsorbate are described by adsorption isotherms, which is usually the ratio between the quantity adsorbed and the remaining in solution at fixed temperature at equilibrium. Freundlich and Langmuir isotherms are the earliest and simplest known relationships describing the adsorption equation (Muhamad et al., 1998; Jalali et al., 2002). Adsorption isotherms are described in many mathematical forms, some of which are based on a simplified physical picture of adsorption and desorption, while others are purely empirical and intended to correlate the experimental data in simple equations with two or at most, three empirical parameters: the more the number of empirical parameters, the better the fit between experimental data (Motoyuki, 1990). Adsorption isotherms have been classified into six characteristic types. Microporous adsorbents produce adsorption isotherms of Type I (which has a convex shape) and it is also associated with monomolecular layer adsorption. Types II and III depict adsorption for multimolecular layer formation while Types IV and V describe the adsorption process of multimolecular layer formation and condensation in pores. Type VI represents surface phase transition of a monomolecular layer on a homogeneous surface (Fried et al., 1977). Type III has a concave shape whereas II, IV, V and VI are sigmoid shape showing a plateau that is, as pressure or concentration increases, amount adsorbed increases slowly first, sharply and then flattens out.

Several isotherm models are available to describe this equilibrium sorption distribution. The Langmuir equation is used to estimate the maximum adsorption capacity corresponding to complete monolayer coverage on the adsorbent surface and is expressed by:

$$q_e = (q_{\max} K_L C_e) / (1 + K_L C_e) \quad (1)$$

where K_L (dm^3g^{-1}) is a constant related to the adsorption/desorption energy, and q_{\max} is the maximum sorption upon complete saturation of the biomass surface (Horshfall et al., 2004). The linearised form of the above equation after rearrangement is given by:

$$C_e / q_e = 1/q_{\max} K_L + C_e / q_{\max} \quad (2)$$

The experimental data is then fitted into the above equation for linearization by plotting C_e / q_e against C_e .

The Freundlich model named after Freundlich (1926) is an empirical equation used to estimate the adsorption intensity of the sorbent towards the adsorbate and is

Table 4. Freundlich isotherm parameters for Cd(II), Pd (II) and Zn (II) sorption on maize cob and husk.

Metal ions	K_F (L/g)				$1/n$			
	Cob		Husk		Cob		Husk	
	450 μ m	850 μ m	450 μ m	850 μ m	400 μ m	950 μ m	450 μ m	850 μ m
Cd (II)	4.90x10 ⁻⁷	1.02x10 ⁻⁴	1.95x10 ⁻¹⁵	9.46x10 ⁻²⁰	2.9506	2.1078	5.3997	6.8818
Pb(II)	7.12x10 ⁻⁸	1.05x10 ⁻⁶	9.26x10 ⁻¹⁰	4.30x10 ⁻²	3.1365	2.7086	3.6245	1.3286
Zn(II)	1.6447	0.1404	1.66x10 ⁻⁴	0.0907	0.9571	1.3363	2.3229	1.3606

Source: Igwe and Abia (2003).

Table 5. Langmuir and Freundlich parameters at different pH conditions for Cu (II) adsorption on *Ulva reticulata*.

pH	Langmuir parameters		R^2	Freundlich parameters		R^2
	Q_{max} (mg/g)	B (L/mg)		K (L/g)	N	
3.0	45.25	0.00256	0.9869	0.555	1.638	0.9877
3.5	53.48	0.00290	0.9761	0.770	1.682	0.9782
4.0	65.36	0.00361	0.9760	1.275	1.785	0.9772
4.5	69.93	0.00567	0.9863	1.919	1.947	0.9743
5.0	70.92	0.00567	0.9836	2.853	2.146	0.9840
5.5	74.63	0.00804	0.9570	4.268	2.351	0.9828
6.0	72.46	0.00727	0.9616	3.724	2.279	0.9836

Source: Vijayaraghan et al. (2005).

given by:

$$q_e = K_F C_e^{1/n} \quad (3)$$

where, q_e = the adsorption density (mg of metal ion adsorbed/g biomass); C_e = concentration of metal ion in solution at equilibrium (mg/L); K_F and n are the Freundlich constants which determines the curvature and steepness of the isotherm (Akgerman and Zardkoohi, 1996). Also, the value of n indicates the affinity of the adsorbate towards the biomass. The above equation is conveniently used in linear form as:

$$\ln q_e = \ln K_F + (1/n) \ln C_e \quad (4)$$

A plot of $\ln C_e$ against $\ln q_e$ yielding a straight line indicates the conformation of the Freundlich adsorption isotherm. The constants $1/n$ and $\ln K_F$ can be determined from the slope and intercept, respectively.

The Dubinin-Radushkevich model is used to estimate the characteristic porosity of the biomass and the apparent energy of adsorption. The model is represented by:

$$q_e = q_D \exp (-B_D [RT \ln (1 + 1/C_e)]^2) \quad (5)$$

where B_D is related to the free energy of sorption per mole of the sorbate as it migrates to the surface of the biomass from infinite distance in the solution and q_D is the Dubinin-Radushkevich isotherm constants related to the degree of sorbate sorption by the sorbent surface (Horshfall et al., 2004). The linear form of the equation is

given by:

$$\ln q_e = \ln q_D - 2B_D RT \ln (1 + 1/C_e) \quad (6)$$

A plot of $\ln q_e$ against $RT \ln (1 + 1/C_e)$ yielding a straight line confirms the model. The apparent energy of adsorption from Dubinin-Radushkevich isotherm model can be computed using the relationship (Horshfall et al., 2004):

$$E = 1/(2B_D)^{1/2} \quad (7)$$

Another sorption isotherm is Florry – Huggins, which is given by:

$$\log (\Theta / C) = \log K_a + n \log (1 - \Theta) \quad (8)$$

Where, Θ is the degree of surface coverage, n is the number of metal ion's occupying sorption site, K_a is equilibrium constant of adsorption and C is equilibrium metal ion concentrations. A plot of $\log (\Theta/C)$ against $\log (1 - \Theta)$ yielding a straight line confirms the model. K_a and n are determined from the intercept and slope respectively.

Several other isotherm exists, these includes the BET (Brunauer, Emmeth and Teller) isotherm, the Temkin isotherm, the Harkins and Jura isotherm, the Frumkin isotherm, the Gibbs isotherm, the Redlich-Petersen isotherm, the Toth isotherm, the Lineweaver-Burk isotherm, and so on. The results obtained from several researches using these isotherm models is shown on Tables 4, 5 and 6. Generally, these isotherms show how

Table 6: Florry – Huggins isotherm parameters for cd (II) and Pb (II) on to *caladium bicolor* (wild cocoyam).

PH	Pb (II)		Cd (II)	
	Ka	ΔG° (KJ mol ⁻¹ K ⁻¹)	Ka	ΔG° (KJ Mol ⁻¹ K ⁻¹)
2	0.732	-0.786	0.467	-0.476
3	0.614	-1.229	0.828	-0.656
4	0.549	-1.511	0.771	-1.390
5	0.48	-1.516	0.583	-1.920
6	0.567	-1.430	0.628	-1.172
7	0.544	-1.534	0.553	-1.493
8	0.553	-1.493	0.651	-1.082

Source: Horsfall and spiff (2004).

adsorptions take place and may serve as design parameters in the treatment of heavy metals from waste water. The very high and good correlation coefficients (R²) gotten from this models, depicts good fit for the various sorption processes that were examined.

Sorption Kinetics and Intraparticulate diffusivity

The kinetics of sorption of heavy metals from wastewater have been studied using mostly pseudo-first order and pseudo-second order reaction models. The pseudo-first order is given by (Lagergren, 1989):

$$d q_t / dt = K_1 (q_e - q_t) \tag{9}$$

where q_e and q_t are the adsorption capacity at equilibrium and at time t, respectively (mg/g); K₁ is the rate constant of pseudo first-order adsorption (L/min). After integration and applying boundary conditions t = 0 to t = t and q_t = 0 to q_t = q_t, the integrated form of Equation (9) becomes:

$$\log (q_e - q_t) = \log q_e - k_1 t / 2.303 \tag{10}$$

When the values of log (q_e - q_t) are linearly correlated with t and a plot of log (q_e - q_t) against t gives a straight line, then we have a good fit for the pseudo-first order kinetic model. K₁ and q_e can be determined from the slope and intercept of the plot, respectively.

The pseudo-second order reaction kinetic is expressed as (Ho et al., 2000):

$$d q_t / d t = K_2 (q_e - q_t)^2 \tag{11}$$

Where, K₂ is the rate constant of pseudo second-order adsorption (g/mg-min). For the boundary conditions t = 0 to t = t and q_t = 0 to q_t = q_t, the integrated form of equation (11) becomes:

$$1 / (q_e - q_t) = 1/q_e + K t \tag{12}$$

which is the integrated rate law for a pseudo second-

order reaction. Equation (12) can be rearranged to obtain equation (13), which has a linear form:

$$t / q_t = 1/(K_2 q_e^2) + t/q_e \tag{13}$$

if the initial adsorption rate h (mg/g-min) is:

$$h = K_2 q_e^2 \tag{14}$$

then, equation (13) and (14) becomes:

$$t / q_t = 1/h + t / q_e \tag{15}$$

The plot of (t/q_t) against t using equation (13) should give a linear relationship from which q_e and K₂ can be determined from the slope and intercept of the plot, respectively.

Another kinetic model that was applied by Demirbas et al. (2004) is the Elovich equation. This equation is expressed as (Chien and Clayton, 1980; Sparks, 1986):

$$d q_t / dt = \infty \exp (-\beta q_t) \tag{16}$$

Where ∞ is the initial adsorption rate (mg/g-min); β is the desorption constant (g/mg) during any one experiment. To simplify the Elovich equation, Chien and Clayton (1980) assumed ∞ β t >> t and by applying the boundary conditions q_t = 0 at t = 0 and q_t = q_t at t = t, equation (16) becomes:

$$q_t = 1/ \beta \ln (\infty \beta) + 1/ \beta \ln (t) \tag{17}$$

Thus, a plot of q_t against ln (t), should give a straight line if Elovich equation gives a good model. The results obtained by some researches using the first and second pseudo-order kinetic models are shown on Table 7 and that using the Elovich equation is given on Table 8.

Several models have been proposed and tested for the intraparticle diffusion of heavy metal removal using biosorbents. The sorption rate is known to be controlled by several factors including the following processes (Findon et al., 1993; Weber and DiGiano, 1996): (i)

Table 7: Kinetic parameters for the effect of initial copper concentration.

Initial conc. (mg/L)	Ki (min ⁻¹)	Qe (mg/g)	R ²	K ₂	Qe (mg/g)	h (mg/g min)	R ²
250	0.0626	24.13	0.9519	0.0111	37.04	14.98	1.0000
500	0.0438	21.66	0.8349	0.0091	57.80	29.73	1.0000
750	0.0251	27.41	0.8929	0.0035	69.44	16.38	0.9999
1000	0.0205	24.18	0.8671	0.0027	71.43	13.23	0.9999

Source: Vijayaraghan et al. (2005).

Table 8. Kinetic parameters using Elovich equation for cornelian cherry (c c), apricot stone (AS) and almond shells (ASC) adsorbents.

Adsorbent	Initial pH	Elovich model		
		β		R ²
CC	1.0	33.901	0.126	0.989
	2.0	16.705	0.138	0.965
	3.0	2.341	0.242	0.967
	4.0	3.794	0.641	0.898
AS	1.0	212.909	0.202	0.981
	2.0	76.150	0.189	0.962
	3.0	112.667	0.358	0.938
	4.0	17.056	0.283	0.975
ASC	1.0	47.956	0.354	0.974
	2.0	9.761	.476	0.909
	3.0	9.524	0.535	0.859
	4.0	8.736	0.475	0.908

Source: Demirbas et al. (2004).

diffusion of the solute from the solution to the film surrounding the particle, (ii) diffusion from the film to the particle surface (external diffusion), (iii) diffusion from the surface to the internal sites (surface diffusion on pore diffusion), and (iv) uptake which can involve several mechanisms. Bulk diffusion (i) is non-limiting when agitation is sufficient to avoid concentration gradients in solution; sorption is seen as a quasi-instantaneous mechanism (Guibal et al., 1998). External mass-transfer resistance (ii) and intraparticle mass-transfer resistance (iii) are likely to be rate controlling.

Mckay and Poots (1980) proposed one model for intraparticle diffusion given by:

$$q_t = X_i + K^1 t^{1/2} \quad (18)$$

The slope of the linear part of the curve (uptake capacity Vs square root time) gives the initial rate of sorption, controlled by intraparticle diffusion, K^1 (mg g⁻¹ min^{-0.5}) (Mckay and Poots, 1980). The initial curved portion of the plot is attributed to boundary layer diffusion effects (i.e., external film resistance). The extrapolation of the linear straight lines to the time axis gives intercepts X_i which is proportional to the boundary layer thickness.

Crank (1975) proposed a model whereby diffusion is controlled only by intraparticle mass transfer for a well-

stirred solution of limited volume (V), assuming the solute concentration always being uniform (initially C_0) and the sorbent sphere to be free from solute. Under these conditions, the total amount of solute M_t (mg/g) in a spherical particle after time t, expressed as a fraction of the corresponding quantity after infinite time (M^∞ , mg/g) is given by:

$$\frac{M_t}{M^\infty} = 1 - \frac{6\alpha(\alpha+1) \exp(-Dq_n^2 t/d^2)}{9 + 9\alpha + q_n^2 \alpha^2} \quad (19)$$

Where, D is the intraparticle diffusion Coefficient (m² min⁻¹) and d is the particle diameter (m). The fractional attainment to equilibrium (FATE) may be used to estimate the intraparticle diffusion coefficient D, when the external diffusion coefficient is being neglected. α is the effective volume ratio, expressed as a function of the equilibrium partition coefficient (solid/liquid concentration ratio) and is obtained by the ratio $C^\infty / (C_0 - C^\infty)$. q_n represents the non zero solutions of equations:

$$\tan q_n = 3q_n / (3 + \alpha q_n^2) \quad (20a)$$

and

$$\frac{M_t}{VC_0} = 1 / (1 + \alpha) \quad (20b)$$

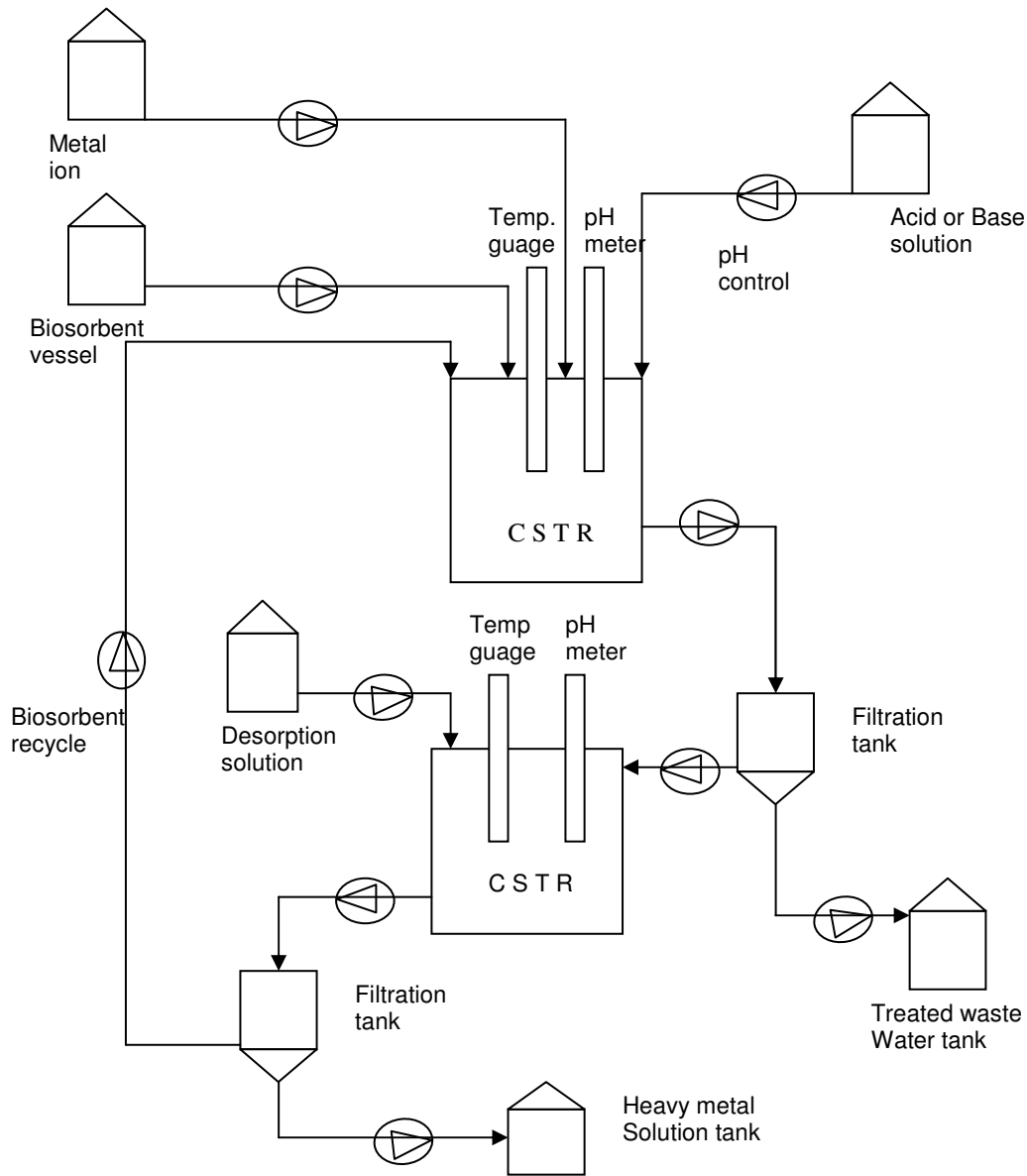

Figure 1. Schematic of Bioseparation process flow diagram for heavy metal sorption from wastewater using biosorbents.

The infinite sum terms are summed until the summation does not vary.

Another model for the intra-particle diffusion is that developed by using the linear driving concept and proposed as (Igwe and Abia, 2005):

$$\ln(1 - \infty) = -K_p t \tag{21}$$

Where K_p is the intra-particle diffusion constant (min^{-1}) and ∞ is FATE, given by:

$$\infty = \frac{[M]_t^{nt}}{[M]_{\infty}^{nt}} \tag{22}$$

$[M]$ is the concentration of metal ion of charge $n+$ at time t and at equilibrium or infinity ∞ . A plot of $\ln(1 - \infty)$ against t gives a straight line if this model gives a good fit to the sorption process.

The intraparticle diffusion model can also be expressed as (Weber and Morris, 1963; Srivastava et al., 1989):

$$R = K_{id} (t)^a \tag{23}$$

A linearised form of the equation is followed by:

$$\log R = \log K_{id} + a \log (t) \tag{24}$$

Where R is the percent heavy metal adsorbed; t is the contact time (min); a is the gradient of linear plots. K_{id} is the intraparticle diffusion rate constant (min^{-1}); a, depicts the adsorption mechanism; K_{id} may be taken as a rate factor i.e., percent heavy metal adsorbed per unit time.

In all these models, a good fit to the experimental data means that the sorption rate is governed by intraparticle diffusion. This means that the intraparticle diffusion process is the rate-limiting step. Higher values of the intraparticle rate constants illustrate an enhancement in the rate of adsorption, whereas larger values illustrate a better adsorption mechanism. Several workers have employed one or combinations of these models in the analysis of the intraparticle diffusion processes for heavy metal adsorption on biosorbents (Igwe and Abia 2005; Demirbas et al., 2004; Guibal et al., 1998).

Bioseparation process flow diagram

Studies about the technological aspects of heavy metal removal by biosorbents are scarce (Volesky and Holan, 1995). Kasia et al. (2005) reported a schematic of the bioreactor design for the removal of nitrogenous compounds from metal-processing wastewater. An experimental setup for the extraction of heavy metals from aqueous solutions, have also been reported by Hussein et al. (2005). The design and probably the fabrication of a small scale bioseparation process unit for the removal of heavy metals will be much welcome.

In this review, we put forward the schematic of a bioseparation process flow diagram for heavy metal sorption from wastewater using biosorbents (Figure 1). The wastewater, especially heavy metal bearing wastewater is discharged into a collecting tank. Biosorbent is also held in a tank after pretreatment and activation. The two are allowed to flow into a continuously stirred tank reactor (CSTR) where the adsorption takes place after a specified hydraulic retention time (HRT). The solution is allowed to flow into a filtration tank where the adsorbent loaded with heavy metal is separated from the treated wastewater. The treated wastewater is collected whereas the metal saturated biomass is pumped into another CSTR where desorption takes place, then followed by filtration and the heavy metal solution is collected which may need some other purification processes. The used adsorbent is then recycled.

The proper design calculations, material and energy balance calculations and even fabrication of a pilot plant may be carried out with the help of such data that was obtained from the experimental runs, isotherm studies, kinetics of sorption and/or intraparticle diffusion studies that had been discussed earlier. We do believe that this is the area where much research is needed. For instance, equation (4) could be rearranged to give:

$$\log [(Co - Ce)/M] = \log KF + 1/n \log Ce \quad (25)$$

where Co is the initial concentration (mg/l) and M is the mass of adsorbent (g). From equation (25), the amount of adsorbent M for the removal of different metal ions from initial concentration Co to equilibrium concentration Ce can be calculated. This will help to regulate the biomass loading and also duration of replacement of adsorbents.

CONCLUSION

We have reviewed the sources and toxicology of heavy metals as well as the reason why they need to be removed from our environment. Conventional methods of removal are expensive, hence the use of low cost, abundant environmentally friendly biosorbents have been tested. Although biosorption is promising, its mechanism is not well elucidated. This knowledge is essential for understanding the process and it serves as a basis for quantitative stoichiometric considerations, which are fundamental for mathematical modeling and scale-up.

REFERENCES

- Abia AA, Horsfall M, Jnr, Didi O (2003). The use of Chemically modified and unmodified cassava waste for the removal of Cd, Cu and Zn ions from aqueous solution. *Bioresour. Technol.* 90 (3): 345-348.
- Ademorati CMA (1996). *Environmental Chemistry and Toxicology. Pollution by Heavy metals.* Foludex press Ibadan. pp. 171-172.
- Akgerman A and Zardkoohi M (1996). Adsorption of phenolic compounds on Fly Ash. *J. Chem. Eng. Data.* 41: 185-191.
- Alda JO, Garay R (1990). Chloride (or bicarbonate) dependent copper uptake through anion exchanger in human red blood cells. *Am. J. Physiol.* 259: 570-576.
- Ali A, Bradley AK, Duong DD (1998). Comparison of Equilibria and kinetics of high surface area activated carbon produced from different precursors and by different chemical treatments. *Ind. Eng. Chem. Res.* 37(4): 1329-1334.
- Anderson RA (1998). Effects of chromium on body composition and weight loss. *Nutr. Rev.* 56(9): 266-270.
- Asku Z, Kutsal T, Gun S, Haciosmanoglu N, Gholminejad M (1991). Investigation of biosorption of Cu(ii), Ni (ii), and Cr(vi) ions to activated sludge bacteria. *Environ. Technol.* 12: 915-921.
- Asmatullah, Qureshi S N, Shakoori AR (1998). Hexavalent chromium induced congenital abnormalities in chick embryos. *J. Appl. Toxicol.* 18(3): 167-171.
- Benito Y, Ruiz ML (2002). Reverse osmosis applied to metal finishing wastewater. *Desalination.* 142(3): 229-234.
- Charkrabarty AK, Saha KC (1987). Arsenical dermatosis from tubewell water in west Bengal. *India J. Med. Res.* 85: 326-331.
- Chen JP, Chang KC (1994). Immobilization of chitinase on a reversibly soluble-insoluble polymer for chitin hydrolysis. *J. of Chem. Technol. Biotechnol.* 60(2): 133-140.
- Chen L, Dixon K (1998). Analysis of repair and mutagenesis of chromium induced DNA damage in yeast mammalian cells and transgenic mice. *Environ. Health Perspect.* 106: 1027-1032.
- Chia-Chang L, Hwai-shen L (2000). Adsorption in a centrifugal field: Basic dye adsorption by activated carbon. *Ind. Eng. Chem. Res.* 39:161-166.
- Chien SH, Clayton WR (1980). Application of Elovich equation to the kinetics of phosphate release and sorption on soils. *Soil Sci. Soc. Am. J.* 44: 265-268.
- Costa ACA, Leite SGC (1991). Metal biosorption by sodium alginate immobilized *chlorerella homosphaera*, *Biotechnol. letter.* 13: 559-562.

- Crank J (1975). The mathematics of Diffusion; Chlarendon press: Oxford. pp. 12-14.
- Davis JA, Volesky B, Vierra RHSF (2000). Sargassum seaweed as biosorbent for heavy metals. *Water Res.* 34 (17): 4270-4278.
- Deleo PC, Ehrlich H L (1994). Reduction of hexavalent chromium by *Pseudomonas fluorescens* LB 300 in batch and continuous cultures. *Appl. Microbiol. Biotechnol.* 40: 756-759.
- Demirbas E, Kobya M, Senturk E, Ozkan T (2004). Adsorption kinetics for the removal of chromium (vi) from aqueous solutions on the activated carbons prepared from agricultural wastes. *Water SA.* 30(4): 533-539.
- Desphande MV (1986). Enzymatic degradation of Chitin and its biological applications. *J. Sci. Ind. Res.* 45: 277-201.
- Dupond L, Guillon E (2003). Removal of hexavalent chromium with a lignocellulosic substrate extracted from wheat bran. *Environ. Sci. Technol.* 37: 4235-4241.
- El-Nady FE, Atta MM (1996). Toxicity and bioaccumulation of heavy metals to some marine biota from the Egyptian coastal waters. *J. Environ. Sci. Health. A-31* (7): 1529-1545.
- Endo T, Kimura O, Sakata M (1996). Effects of zinc and copper on uptake of cadmium by LLC-PK1 cells. *Biol. Pharm. Bull.* 19: 944-948.
- Eromosele IC, Otitolaye OO (1994). Binding of iron, zinc and lead ions from aqueous solution by shea Butter (*Butyrospermum parkiz*) seed husk. *Bull. Environ. Contam. Toxicol.* 52, 530-537.
- Faisal M, Hasnain S (2004). Microbia conversion of Cr(vi) into Cr(iii) in industrial effluent. *African J. Biotechnol.* [online]. 3(11): 610-617. Available from internet: <http://www.academicjournals.org/AJB>. ISSN 1684-5315.
- Faust SD, Aly OM (1987). Adsorption processes for water Treatment Butterworth Publishers, Boston. pp. 108-113.
- Fedrickson JK, Kostandarithes HM, Li SW, Plymale AE, Daly M J (2000). Reduction of Fe(iii), Cr(vi), U(vi), and Tc(vii) by *Deinococcus radiodurans* R1. *Appl. Environ. Microbiol.* 66(5) : 2006-2011.
- Findon A, McKay G and Blair H. S (1993). Transport studies for the sorption of copper ions by chitosan. *J. Environ. Sci. Health.* 28: 173-185.
- FNB (1974). Recommended dietary allowances. Food and Nutrition Board, National Academy of sciences, Washington D.C.
- Forstner U. and Wittman G. T. W (1979). Metal pollution in the Aquatic Environment. Springer-verleg, Berlin. pp. 13-17.
- Fried V, Hameka HF, Blukis U (1977). Physical Chemistry. Macmillan Publishing Co. Inc. New York. pp. 14-28.
- Gadd G (1990). Heavy metal accumulation by bacteria and other microorganisms. *Experientia.* 46: 834-840.
- Gang S, Weixing S (1998). Sunflower stalks as Adsorbents for the removal of metal ions from wastewater. *Ind. Eng. Chem. Res.* 37, 1324-1328.
- Gardea – Torresday JL, Gonzalez JH, Tiemann KJ, Rodrigueuz O, Gamez G (1998). Phytofiltration of Hazardous cadmium, chromium lead and zinc ions by biomass of *Medicago sativa* (Alfalfa). *J. Hazard. Matter* 57: 29-39.
- Gavrilescu M. (2004). Removal of Heavy metal from the Environment by Biosorption. *Eng. life Sci.* 4(3): 219-232.
- Ghosh MM, Yuan JR (1987). Adsorption of inorganic arsenic and organoarsenicals on hydrous oxide. *Environ Prog.* 6: 150
- Guibal E, Rouph C, LE Cloirec P (1992). Uranium biosorption by a filamentous fungus *Mucor miehei*, pH effect on mechanisms and performances of uptake. *Water Res.* 26: 1139-1145.
- Guibal E, Milot C, Tobin MJ (1998). Metal – Anion sorption by Chitosan beads: Equilibrium and kinetic studies. *Ind. Eng. Chem. Res.* 37: 1454-1463.
- Gupta SK, Chen KY (1978) Arsenic removal by adsorption. *J. water polut. Control Fed.* 50: 493
- Ho YS, John Wase DA, Forster CF (1995). Batch nickel removal from aqueous solution by sphagnum moss peat. *Water Res.* 29(5): 1327-1332.
- Ho YS, McKay G, Wase DAJ, Forster CF (2000). Study of the sorption of divalent metal ions onto peat. *Adsorp. Sci. Technol.* 18: 639-650.
- Hodi M. Polyak K., Htavay J. (1995). Removal of pollutants from drinking water by combined ion-exchange and adsorption methods. *Environ. Int.* 21: 325 -329.
- Horsfall M Jnr. And Abia A. A (2003). Sorption of cadmium (ii) and zinc(ii) ions from aqueous solutions by cassava waste biomass (*Manihot sculenta cranz*). *Water Res.* 37(20): 4913-4923.
- Horsfall, M. Jnr. And Spiff, A. I. (2004). Studies on the effect of pH on the sorption of pb²⁺ and cd²⁺ ions from aqueous solutions by caladium bicolor (wild cocoyam) biomass. *Electronic J. Biotechnol.* [online]. 15 December 2004 vol 7, no 3. Available from Internet: <http://www.ejbiotechnology.info/content/vol7/issue3/full/8/index.html>. ISSN 07173458.
- Horsfall M Jnr. And Spiff, A. I. (2005). Effects of temperature on the sorption of ob²⁺ and cd²⁺ from aqueous solution by caladium bicolor (wild cocoyam) biomass. *Electronic Journal of Biotechnology* [online]. 15 August 2005, vol 8, no 2. Available from Internet: <http://www.ejbiotechnology.info/content/vol8/issue2/full/4/index.html>. ISSN 0717-3458
- Hsisheng T, Chien-To H (1998). Influence of surface characteristics on liquid phase Adsorption of phenol by activated carbon prepared from Bituminous coal. *Ind. Eng. Chem. Res.* 37(9); 3618-3624.
- Huang CP, Fu PLK (1984). Treatment of arsenic (v) containing water by the activated carbon process. *J. water pollut. Control Fed.* 56: 233-237.
- Hussein H, Ibrahim S F, Kandeel K, Moawad H (2005). Biosorption of heavy metals from waste water using *Pseudomonas sp*. *Electronic J. Biotechnol.* [online]. 14 July 2005, Vol.7 no 1. Available from Internet: <http://www.ejbiotechnology.info/content/vol7/issue1/full/2/index.html>. ISSN 0717-3458
- Igwé JC, Abia AA (2003). Maize Cob and Husk as Adsorbents for removal of Cd, Pb and Zn ions from wastewater. *The physical Sci.* 2: 83-94.
- Igwé JC, Abia AA (2005). Sorption kinetics and intraparticulate diffusivities of Cd, Pb and Zn ions on maize cob, Pb and Zn ions on maize cob. *Afr. J. Biotech.* 4(6): 509-512.
- Igwé JC, Okpareke OC, Abia AA (2005a). Sorption kinetics and intraparticulate diffusivities of Co, Fe and Cu ions on EDTA-modified maize cob. *Intern. J. Chem. India* 15(3): 187-191.
- Igwé JC, Ogunewe DN, Abia AA (2005c). Competitive adsorption of Zn(ii), Cd(ii) and Pb(ii) ions from aqueous and non-aqueous solution by maize cob and husk. *Afr. J. Biotechnol.* 4(10): 1113-1116.
- Igwé JC, Iroh CU, Abia AA (2005a). Removal of Hg²⁺, pb²⁺ and Ni²⁺ ions from wastewater using modified Grammlar Activated carbon (GAC); Adsorption and Kinetic Studies. *J. Environ. Managt.* (in press).
- Igwé JC, Nwokennaya EC, Abia A. A. (2005b). The role of pH in heavy metal detoxification by biosorption from aqueous solutions containing chelating agents. *Afr. J. Biotechnology* 4(10): 1113-1116.
- Igwé JC, Ibeh AC, Abia AA (2005e). Sorption kinetics and intraparticulate diffusivities of Hg(ii), As(iii) and Pb(ii) ions detoxification from wastewater using modified coconut fiber. *Water S A* (in press).
- Ilyina AV, Tikhonov VE, Varlamov VP, Radigina LA, Tatarinova NY, Yanskov IA (1995). Preparation of affinity sorbents and isolation of individual chitinases from crude supernatant produced by streptomyces kurssanovii by a one-step affinity chromatographic system. *Biotechnol. And Appl. Biochem.* 21(2): 139-148.
- Ioannis AK, Zouboulis A. I (2004). Application of biological processes for the removal of arsenic from groundwaters. *Water Res.* 38(1): 17-26.
- Jackson AP, Alloway BT (1991). The bioavailability of cadmium to lettuce and cabbage in soils previously treated with sewage sludges. *Plant soils.* 132: 179-186.
- Jalali R, Ghafourian H, Asef D, Sepehr S (2002). Removal and recovery of lead using non-living biomass of marine algae. *J. Hazard. matter.* 92(3): 253-262.
- Kapoor A, Viraraghavan J (1995). Fungal biosorption – an alternative treatment option for heavy metal bearing wastewater: a review. *Bioresour. Technol.* 53(3): 195-206
- Kasia JM, Duncan JR, Burgess JE (2005). Biological removal of nitrogen species from metal-processing wastewater. *Water SA* 31(3): 407-411.
- Kasuya M, Teranishi H, Aohima K, Katoh T, Horiguchi N, Morikawa Y, Nishijo M, Iwata K (1992). Water pollution by cadmium and the onset of "itai-itai" disease. *Water Sci. Technol.* 25: 149-156.

- Keith LH, Tellard WA (1979). Priority pollutants. *Environ. Sci. Tech.* 13: 416-424.
- Klaassen CD (2001). Heavy metals and Hardmen JG, Limbird LE, Gilman AG (eds). Goodman and Gilman's: The pharmacological Basis of Therapeutics, McGraw Hill, New York. pp. 1851-1875.
- Krishnani KK, Parmala V, Meng X (2004). Detoxification of chromium (vi) in coastal waste using lignocellulosic agricultural waste. *Water SA* 30(4): 541-545.
- Lagergren S (1898). Zur Theorie der adsorption geloster stoffe, kungliga svenska ventenskapsatemiens. *Handler* 24: 1-39.
- Lopez MC, Cabrea C, Gallego C, Lorenzo ML (1994). Cadmium levels in waters of Canada Coast. *Arch. Pharm.* 1: 945-950.
- Lou M, Garray R, Alda J (1991). Cadmium uptake through the anion exchange in human red blood cells. *J. Physiol.* 443: 123-136.
- Low KS, Lee CK, Leo AC (1995). Removal of metals from electroplating wastes using banana pith. *Bioresour. Technol.* 51 (2-3): 227-231.
- Lu Y, Wu C, Lin W, Tang L., Zeng H (1994). Preparation and Adsorption properties of the chelating Fibers containing Amino Groups.. *J. Appl. Polym. Sci.* 53: 1461-1468.
- Macaskie LE (1990). An immobilized cell bioprocess for removal of heavy metals from aqueous flows.. *J. Chem. Technol. And Biotechnol.* 49: 330-334.
- McLaughlin MJ, Tiller RG, Naidu R, Stevens DP (1996). Review: the behaviour and environmental impact of contaminants in fertilizers. *Aust. J. Soil Res.* 34: 1-54.
- Mckay G, Poots VJ (1980). Kinetics and diffusion processes in colour removal from effluent using wood as an adsorbent. *J. Chem. Technol. Biotechnol.* 30: 279-292.
- Mclean J, Beveridge TJ (2001). Chromate reduction by a pseudomonad isolated from a site contaminated with chromated copper arsenate. *Appl. Environ. Microbiol.* 67: 1076-1084.
- Mertz W (1993). Chromium in Human nutrition: a review *J. Nutr.* 123: 626 – 635.
- Monser L, Adhoun N (2002) Modified activated carbon for the removal of copper, zinc, chromium and cyanide from wastewater. *Separation and Purification Technol.* 26(2-3) 137 – 146.
- Motoyuki S (1990). Adsorption Engineering. Elsevier Sci. Publishers. pp. 5 – 61.
- Muhamad N, Parr J, Smith DM, Wheatley DA (1998). Adsorption of heavy metals in show sand filters in: Proceedings of the WEDC conference sanitation and water for all (24⁰, 1998, Islamabad, Pakistan). pp. 346 – 349.
- Muraleadharan TR, Iyengar L, Venkobachar C (1995). Screening of tropical wood-rotting mushrooms for copper biosorption. *Appl. Environ. Microbiol.* 61(9): 3507- 3508.
- Muraleadharan TR, Leela I, Venkobachar C (1991). Biosorption: An attractive alternative for metal removal and recovery. *Current Sci.* 61: 379 – 385.
- Namasivagam C, Senthilkumar S (1998) Removal of Arsenic (V) from aqueous solution using industrial solid waste: Adsorption Rates and Equilibrium studies. *Ind. Eng. Chem. Res.* 37(12): 4816 – 4822.
- Neal BG, Lawrence EB, Wendt JL (1990) Alkali metal partitioning in Ash from pulverized coal combustion. *Combust. Sci. Tech.* 74: 211 – 214.
- Ngah WS, Liang KH (1999) Adsorption of Gold (III) ions onto chitosan and N – carboxymethyl chitosan: Equilibrium studies. *Ind. Eng. Chem. Res.* 38(4): 1411 – 1414.
- Ouki SK, Neufeld RD, Perry R (1997). Use of activated carbon for the recovery of chromium from industrial wastewaters. *J. chem. technol. and Biotechnol.* 70(1): 3 – 8.
- Pagnanelli F, Petrangeli MP, Toro L, Trifoni M, Veglio F (2000). Biosorption of metal ions on *Arthrobacter* sp. Biomass characterization and bisorption modeling. *Environ. Sci. Technol.* 34(13): 2773 – 2778.
- Park S, Jung WY (2001) Removal of chromium by activated carbon fibers plated with copper metal. *Carbon Sci.* 2(1): 15 – 21.
- Preetha B. and Viruthagiri T. (2005). Biosorption of Zinc(II) by *Rhizopus arrhizus*: equilibrium and kinetic modeling. *Afr. J. Biotechnol.* 4(6): 506 – 508.
- Puranik PR, Paknikar KM (1997) Biosorption of lead and zinc from solutions using streptovorticillium cinnamomeum waste biomass. *J. Biotechnol.* 55, 113 – 124.
- Quek SY, Wase DAJ, Foster CF (1998). The use of sago waste for the sorption of lead and copper. *Water S A.* 24(3): 251 – 256.
- Rajakovic LV, Miltrovic MM (1972). Arsenic removal from water by chemisorption filters. *Environ. Pollut.* 75: 279.
- Raji C, Amirudhan TS (1998) Batch Cr (VI) removal by polyacrylamide – grafted saw dust: kinetics and thermodynamics. *Water Res.* 32(12) 3772 – 3780.
- Ralph TY, Richard QL, Joel P, Tomonori T, Akira T (1999). Adsorbents for Dioxins: A new technique for sorbent screening for low – volatile organics. *Ind. Eng. Chem. Res.* 38(7): 2726 – 2731.
- Randell JM, Reuter FC, Waiss AC (1994). Removal of cupric ions from solution by contact with peanut skins. *J. Appl. Polymer Sci.* 19: 156 – 171.
- Rao C.R.N.; Iyengar L.; Venkobachar C. (1993). Sorption of copper(II) from aqueous phase by waste biomass. *J. of Environ. Eng. Div., ASCE*, 119: 369 – 377.
- Reddad Z, Zerente C, Andres Y, Cloriec P, PLE. (2003). Mechanisms of Cr(III) and Cr(VI) removal from aqueous solutions by sugar beat pulp. *Environ. Toxicol* 24: 257 – 264.
- Reed BF., Arnnachalam S., Thomas B. (1994). Removal of lead and Cadmium from aqueous waste streams using Granular activated carbon (GAC) columns. *Environ. Prog.* 13: 60 – 65.
- Rengaraj S, Yeon KH, Moon SH (2001). Removal of chromium from water and wastewater by ion exchange resins, *J. Hazardous materials* 87(1-3): 273 – 287.
- Rhode B, Hartmann G (1980). Introducing mycology by examples. Schering Aktrengese ellschaft, Hamburg.
- Rome L, Gadd GM (1987). Copper adsorption by *Rhizopns arrhizns cladospoium resinae* and *penicillium italicum*. *Appl. Microbiol and Biotechnol.* 26: 84 – 90.
- Sadiq M, Zaida TH, Mian AA (1983). *Water Air, soil pollut.* 20: 369 – 374.
- Saifuddin MN, Kuruaran P (2005) Removal of heavy metal from industrial wastewater using chitosan coated oil palm shell charcoal. *Electronic J. Biotechnol.* (online). 20 Jan. 2005, vol. 8, no. 1. <http://www.ejbiotechnology.info/content/vol8/issue1/full/7/index.html>. ISSN.0717-458.
- Schumann K. (1990). The toxicological estimation of the heavy metal content (Cd, Hg, Pb) in food for infants and small children. *Z. Ernährungswiss* 29: 54 – 73.
- Shim JW, Park SJ, Ryn SK (2001) Effect of modification with HNO₃ and NaOH by pitch based activated carbon fibers. *Carbon.* 39(11): 1635 – 1642.
- Shigetomi Y, Hori Y, Kojima T (1980) The removal of arsenate in wastewater with an adsorbent prepared by binding hydrons iron(III) oxide with polyacrylamide *Bull. Chem. Soc. Jpn.* 53: 1475 – 1482.
- Shumilla AJ, Broderick JR, Wang Y, Barchowsky A. (1999). Chromium Cr(VI) inhibits the transcriptional activity of nuclear factor – B by decreasing the interaction of p65 with c AMP – responsive element – binding protein. *J. Biol. Chem.* 274(51): 36207 – 36212.
- Sparks DL (1986). Kinetics of Reaction in pure and mixed systems, in soil physical chemistry. CRC press, Boca Raton. pp. 14 – 22.
- Srivastava SK, Tyagi R, Pant N (1989) Adsorption of heavy metals on carbonaceous material developed from the waste slurry generated in local fertilizer plants. *Water Res.* 23: 1161 – 1165.
- Townsley CC, Ross IS, Atkins AS (1986). Biorecovery of metallic residues from various industrial effluents using filamentous fungi.. *Process metallurgy* 4: 279 – 289.
- Tsezos M, Volesky B (1981) Biosorption of Uranium and thorium. *Biotechnol. and Bioeng.* 23: 583 – 604.
- Udaybhaskar P, Iyengar L, Prabhakara RAVS (1990) Hexavalent Chromium interaction with chitosan. *J. Applied Polymer Science.* 39(3): 739 – 747.
- Ukhun ME, Okolie NP, Oyerinde AD (2005). Some mineral profiles of fresh and bottled palm wine – a comparative study. *Afr. J. Biotechnol.* 4(8): 829 – 832.
- Vahter M, Berghund M, Nermell B, Akesson A (1996). Bioavailability of cadmium from shell fish and mixed diet in women. *Toxicol. Appl. Pharmacol.* 136: 332 – 334.
- Vijayaraghan K, Jegan JR, Palanivela K, Velan M (2005). Copper removal from aqueous solution by marine green alga *ulva reticula*. *Electronic J. Biotechnol.* [online]. 14 July 2005, Vol.7 no 1. Available

- from Internet:
<http://www.ejbiotechnology.info/content/vol7/issue1/full/4/index.html>.
SSN 0717-3458.
- Volesky B (1990a). Biosorption and biosorbents. In: Biosorption of heavy metals. Boston, USA, CRC Press. pp. 3 – 5.
- Volesky B (1990b) Removal and recovery of heavy metals. In: Biosorption of heavy metals, USA, CRC Press. pp. 7– 43.
- Volesky B (1994). Advances in biosorption of metals: selection of biomass types. FEMS. Microbiol. Rev. 14: 291 – 302.
- Volesky B, Holan Z (1995). Biosorption of heavy metals. Biotechnol. Prog. 11: 235 – 250.
- Wasay SA, Tokunaga S, Park SW (1996) Removal of hazardous anions from aqueous solutions by La(III) and Y(III) – impregnated alumina. Sep. Sci. Technol. 31: 1501 – 1507
- Wataru T, Hiroyuki Y (1998) Adsorption of Organic acids on polyaminated Highly porous chitosan: Equilibra. Ind. Eng. Chem. Res. 37(4): 1300 – 1309.
- Weber WJ, DiGiano FA (1996). Process dynamics in Environmental systems: Environ. Sci. and Technol. Service, Wiley and Sons, New York. pp. 89 – 94.
- Weber WJ, Morris JC (1963). Kinetics of adsorption on carbon from solution J. Sanit. Eng. Dir. Am. Soc. Civ. Eng. 89: 31 – 60.
- Wolnik KA, Frick FL, Caper SG, Meyer MW, Satzergar RD, (1985). Elements in majors raw agricultural crops n the United States. 3. Cadmium lead and eleven other elements in carrots field corn, onion, rice, spinach and tomatoes. J. Agric. Food Chem. 33: 807– 811.
- Yasuda M, Miwa A, Kitagawa M (1995). Morphometric Studies of renal lesions in “Itai-itai” disease: chronic cadmium nephropathy; Nephron 69: 14 – 19.
- Yurlova L, Kryvoruchko A, Kornilovich B (2002) Removal of Ni(II) ion's from wastewater by micellar enhanced ultrafiltration 144: 255 – 260.