

Full Length Research Paper

Hydrolytic and synthetic activities of esterases produced by *Bacillus* sp. A60 isolated from an oil contaminated soil

Flavia del Valle Loto¹, Cintia Mariana Romero^{1,2}, Alfonso Emanuel Carrizo¹, Mario Domingo Baigori^{1,2} and Licia María Pera^{1*}

¹PROIMI-CONICET, Av. Belgrano y Pasaje Caseros, T4001 MVB, Tucumán, Argentina.

²Facultad de Bioquímica, Química y Farmacia, Batalla de Ayacucho 471, T4000INI, Tucumán, Argentina.

Accepted 9 October, 2013

A novel esterase producer strain named *Bacillus* sp. A60 was isolated from a soil sample contaminated with hydrocarbons. It was found to belong to *Bacillus subtilis* species through morphological, biochemical and 16S rRNA gene sequence analyses. This strain which can tolerate 15% (w/v) NaCl and growth at 55°C, produced an interesting esterase activity in Luria-Bertani medium. Two different molecular weight esterase activities were detected in zymographic assays. Culture supernatant and whole cells showed specific hydrolytic activities of 2.67 ± 0.11 U/mg of protein and 7.07 ± 0.09 U/mg of dry weight, respectively. Concerning ethyl acetate production, conversions of 88.00 ± 0 and $55.58 \pm 0.78\%$ were obtained with culture supernatant entrapped in polyacrylamide gel and whole cells, respectively. In addition, the effect of different concentration of LB medium components on both growth and extracellular esterase hydrolytic activity was also discussed.

Key words: *Bacillus*, esterases, hydrolytic activity, synthetic activity, ethyl acetate.

INTRODUCTION

The broad metabolic diversity exhibited by the genus *Bacillus* coupled to the low pathogenicity of several species, make it a commercially important and an environmental friendly source of enzymes, vitamins and other products. In this connection, the screening of spore-forming bacteria for the production of useful metabolites continues to be an important aspect of biotechnology. Among the enzymes, esterases (E.C. 3.1.1) represent a diverse group of hydrolases catalyzing the cleavage and the formation of ester bonds. They have been extensively explored in the synthesis of flavor esters, in the resolution of racemic mixtures, and in the degradation of natural material as well as industrial pollutants (Panda and

Gowrishankar, 2005). However, the enzymatic production of ethyl acetate, an important environmental friendly solvent, was relatively little investigated (Alvarez-Macarie and Baratti, 2000; Bélafi-Bakó et al., 2003). Thus, the search of new microbial esterases suitable for this application is therefore, very attractive. As an acid inhibition during the esterification of acetic acid and ethanol by Novozyme 435® lipase was also reported by Bélafi-Bakó et al. (2003), the enzyme immobilization could improve its utilization at extreme pH, and also in different solvents, temperatures and high substrate concentrations (Hanefeld et al., 2009). Alternatively, the use of cell-bound enzymes (that is, naturally immobilized enzymes) is an interesting

*Corresponding author. E-mail: lymb@arnet.com.ar.

strategy because it eliminates complex procedures of purifications, so this kind of biocatalysts is cost effective since the biomass can be directly utilized in the reaction (Stergiou et al., 2013). In addition, the cell structure may act as natural matrix protecting the enzymes from the possible negative action of external agents. On the other hand, the selection of an appropriated fermentation technique as well as the optimization of culture conditions for the production of an industrially important target product must be done to ensure good yields and quality (Panda and Gowrishankar, 2005).

In our laboratory, the purification and characterization of esterases and lipases from both spore-forming bacteria and filamentous fungi were evaluated. In addition, the enzymatic synthesis of isoamy acetate and ethyl steareate were also explored (Baigorí et al., 1996; Torres et al., 2009; Romero et al., 2012). In this work, hydrolytic and synthetic activities of esterases produced by *Bacillus* sp A60 isolated from an oil contaminated soil were reported. Some aspects of the enzyme production were also analyzed.

MATERIALS AND METHODS

Microorganisms and fermentation conditions

Bacteria were isolated from different sources such as soils contaminated with hydrocarbons and soils from a river cost in the North West of Argentine. Soil suspensions were heated at 80°C for 15 min, plated on Luria-Bertani (LB) agar and incubated at 37°C. Liquid cultures were carried out in flasks of 125 ml containing 10 ml of LB medium on an orbital shaker at 37°C. The reference strain *Bacillus subtilis* 1A571 (Lindgren and Rutberg, 1974), a derivative of *B. subtilis* wild-type strain 168 (*trp* C2), was kindly provided by the Bacillus Genetic Stock Center, Columbus, Ohio.

Screening of esterase-producing spore-forming microorganisms

Separated colonies of isolated bacteria were grown 48 h on LB agar at 37°C. The enzyme activity was studied by pouring the plates with α -naphthyl acetate and Fast Blue dissolved in 50 mM phosphate buffer pH 7 supplemented with 0.75% agar. A brown halo around the colonies was considered as a positive result for extracellular enzyme activity. The ratio between the diameter of each colony and the corresponding hydrolysis halo ($\text{Ratio}_{C/H}$) was evaluated as an indicator of the strains efficiency to produce an esterase activity; the values ranged from 0 to 1, and the highest level of enzymatic activity was the nearest to 0.

Identification of the spore-forming strain A60

Phenotypic characterization

Gram staining, motility assays, catalase test and starch hydrolysis were performed using standards protocols. Growth at different pH values, temperatures, NaCl concentrations, and motility were carried out as described by Garrity et al. (2005). The API 50 CHB system (bioMérieux) was used according to the manufacturer's instructions. Zymograms were performed in native- polyacrylamide gel electrophoresis (PAGE) using a 10% polyacrylamide gel (Davis,

1964).

Molecular characterization

Total DNA was extracted from cells harvested in the mid-exponential growth phase as described by Miller (1972). Polymerase chain reaction (PCR) amplification was performed in a 25 μ l reaction mix containing 2.5 μ l 10X STR reaction buffer (Promega), 20 ng total DNA, 0.5 μ M of each primer and 1 U of Taq DNA polymerase (Promega). Primers 27 F (5'-AGAGTTTGATCMTGGCTCAG-3') and 1492 R (5'-GGTTACCTTGTTACGACTT-3') were used to generate partial sequences of 16S rDNA. Samples were amplified as follows: 5 min at 94°C; 35 cycles of 1 min at 94°C, 2 min at 50°C and 2 min at 72°C, and at the end, 7 min at 72°C for final extension. PCR products were analyzed by electrophoresis in 2% (wt/vol) agarose gels. DNA sequencing was carried out by MacroGen Services. Sequences were compared and aligned with those from the GenBank database with BLAST software. The method of Jukes and Cantor (1969) was used to calculate evolutionary distances. Phylogenetic dendrogram was constructed with the neighbor-joining method, and tree topology was evaluated by performing bootstrap analysis of 1000 data sets using MEGA 4 software (<http://www.megasoftware.net/>). Partial nucleotide sequence of the 16S rDNA gene of *Bacillus* sp. A60 was deposited in GenBank database under accession number EF513611.

Substrate specificity of esterase activity on LB agar plates

The selected strain *Bacillus* sp. A60 as well as the reference strain *B. subtilis* 1A571 were grown 48 h on LB agar at 37°C. The substrate specificity of the hydrolytic activity was also studied by pouring the plates with α -naphthyl derivatives (α -acetate, α -propionate, α -caproate, α -laurate, α -miristate, α -palmitate and α -stearate) as described for screening assays.

Determination of hydrolytic activity

Hydrolytic activity was measured spectrophotometrically at 405 nm by using *p*-nitrophenyl acetate (*p*NPA) as substrate. All assays were performed at 37°C, and controls were included in which no enzyme or no substrate was added. One unit of enzyme activity (U) was defined as the amount of enzyme that released 1 μ mol of *p*-nitro phenol per min. For extracellular hydrolytic activity, specific activity was expressed as U per mg of protein. Protein concentration was determined with Bradford (1976) reagent. For cell-bound hydrolytic activity determination, cell pellets were washed twice with 50 mM phosphate buffer pH 7, centrifuged and resuspended in the reaction mixture. The reaction was shaken at 150 rpm, and the absorbance of the supernatant was then measured. Specific activity was expressed as U per mg dry weight.

Determination of synthetic activity

Ester synthesis was performed with either entrapped culture supernatant in polyacrylamide gels or dried cells. In the first case, 4.25 ml of culture supernatant were added to a solution containing 0.75 ml of acrylamide-bis acrylamide (30:0.8), 20 μ l of ammonium persulfate solution (0.1 g/ml) and 6 μ l of TEMED solution. Polymerization was performed on a 1 mm width glass case. Pieces of gel (1 x 1 cm) were then cut and used for enzymatic synthesis. Ester synthesis was also evaluated in the presence of microbial biomass; in this experiment, the cells were first washed with *n*-hexane. Then, 1 mg of cells as well as a gel slice were resuspended

Table 1. Medium composition tested for esterase activity.

Medium	NaCl (g/l)	Yeast extract (g/l)	Tryptone (g/l)
1	0	5.0	10.0
2	5.0	5.0	10.0
3	12.5	5.0	10.0
4	10.0	5.0	0
5	10.0	5.0	5.0
6	10.0	5.0	12.5
7	10.0	0	10.0
8	10.0	2.5	10.0
9	10.0	7.5	10.0
10 (LB) ^a	10.0	5.0	10.0

^aLB, Luria Bertani medium.

in 10 ml of n-hexane containing 20 mM of acetic acid and an excess of ethanol. Reactions were incubated at 37°C on an orbital shaker at 150 rpm. After a reaction time of 24 h, the residual acid content was determined by titration with a 0.1 N sodium hydroxide solution. The molar conversion was determined from the values obtained for the blank and the test samples. Qualitative analysis of ethyl acetate production was carried out by thin layer chromatography (TLC) using silica gel 60 as support and chloroform as developing solvent. Spots were visualized in iodine vapor. All assays were carried out at least in duplicate.

Effect of LB components on *Bacillus* sp. A60 growth and hydrolytic esterase production

Different concentrations of LB components were evaluated. The proportions of the components were varied once at a time as detailed in Table 1. All experiments were carried out in triplicate and average values of specific hydrolytic esterase activity as well as biomass were calculated.

Statistical analysis

Statistical analyses was performed using the Minitab (version 14; Minitab Inc) software for windows. Statistical significance values of the means were evaluated using a one-way analysis of variance. Subsequent comparisons were performed using Tukey's post-hoc test. Results were presented as the mean \pm SD. Differences were accepted as significant when $P < 0.05$.

RESULTS AND DISCUSSION

Isolation and selection of the indigenous spore-forming strain A60

A total of 44 spore-forming bacteria showing esterase activity in LB agar were isolated from natural environments. Thirty-four strains (78%) showed both, extracellular and biomass-bound esterase activity (Figure 1a,b), and 10 strains (22%) only displayed a biomass-bound esterase activity (Figure 1c). Interestingly, considering the ratio between the diameter of each colony and the corresponding hydrolysis halo, 17 strains were better producers than the reference strain *B. subtilis* 1A571 (Table 2).

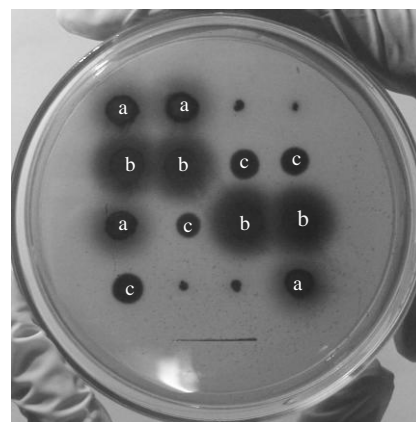

Figure 1. Hydrolytic esterase activity on LB agar plate. Esterase activity was detected using 1.3 mM of α -naphthyl acetate (C2) and 1 mM Fast Blue RR dissolved in 50 mM phosphate buffer pH 7. a, *Bacillus subtilis* 1A571; b, *Bacillus* sp. A60; c, *Bacillus* sp. M2. Scale: 2 cm.

Esterases from this species hydrolyze different substrates as antibiotic esters, and were utilized in chiral drug resolution, among other applications (Bornscheuer, 2002). In our study, the most promising strain named A60 showed the lowest colony diameter to halo diameter ratio ($\text{Ratio}_{C/H} = 0.33$), and was then selected for further studies.

Phenotypic and molecular characterization of *Bacillus* sp. A60

The spore-forming strain A60 stained Gram-positively and formed central oval spores. Growth was observed at pH 5.8, not at pH 10, and the strain was able to grow in LB agar supplemented with 7, 10 and 15% NaCl. Maximum growth temperature was 55°C. According to API 50CH system, carbohydrates fermented were: Glycerol, ribose, D-glucose, D-fructose, N-acetyl-glucosamine,

Table 2. Ratio between the diameter of each isolated colony and the corresponding hydrolysis halo produced by an esterase activity ($\text{Ratio}_{C/H}$).

Strain	$\text{Ratio}_{C/H}$	Strain	$\text{Ratio}_{C/H}$
A6	0.7	A34	1.00
A7	0.64	A35	1.00
A8	0.49	A36	0.46
A9	0.56	A37	0.40
A10	0.6	A38	0.40
A11	0.62	A39	0.58
A12	0.63	A41	0.35
A13	0.35	A43	0.40
A15	1.00	A45	0.64
A16	0.35	A46	0.70
A18	0.38	A49	0.40
A19	0.5	A52	0.40
A20	0.8	A59	0.57
A23	0.42	A60	0.33
A24	1.00	A61	1.00
A25	0.35	M1	1.00
A26	0.4	M2	1.00
A27	0.52	M5	1.00
A28	0.56	M15	0.44
A30	0.37	M19	0.38
A31	1.00	M27	0.40
A32	0.57	1A571	0.42
A33	1.00		

amygdaline, arbutine, esculine, salicine, cellobiose, maltose, saccharose, trehalose, starch, glycogene and gentiobiose. Phenotypic analyses and morphological characteristics strongly suggested A60 strain as *B. subtilis*.

Additionally, the partial sequencing of 16S rDNA gene confirmed the biochemical and morphological characterization. Basic Alignment Search Tool (BLAST) search and alignment analyses showed a similarity of 99% to *B. subtilis* subsp. *subtilis* str. 168. The phylogenetic tree is shown in Figure 2. It is important to mention the biotechnological importance of *B. subtilis* as an organism which lacks of toxicity (considered generally regarded as safe (GRAS) by FDA, USA). Moreover, it is recognized as a source of different metabolites potentially useful in food and detergent industry, pharmaceutical and health technologies and agriculture products (Harwood and Wipat, 1996; Schallmey et al., 2004).

Hydrolytic esterase activity from *Bacillus* sp. A60

The substrate specificity of the hydrolytic activities produced in LB agar by *Bacillus* sp. A60 as well as by the reference strain *B. subtilis* 1A571 was compared. Both esterase activities were able to hydrolyze acetate, propionate and caproate α -naphthyl derivatives. However,

only the esterase from *Bacillus* sp A60 was capable to hydrolyze the laurate derivative. In addition, none of them were able to hydrolyze chromogenic substrates with longer carbon chains. These results strongly suggested that the enzyme activity produced by *Bacillus* sp. A60 corresponds to an esterase activity (Bornscheuer, 2002). Specificity of esterase from *Bacillus* sp. A60 as well as the esterase specificity reported from *Bacillus* sp. 4 (Ateslier and Metin, 2006) were different to that from the reference strain and other known esterases, which commonly showed no activity on substrates with chains longer than 10 carbons. However, it cannot be ruled out that other proteins or carbohydrates originating from the culture broth could contribute to a more robust catalytic system.

Zymograms of *Bacillus* sp. A60 supernatant showed two bands of activity with apparent molecular weights of 101.35 ± 0.31 and 50.10 ± 0.07 kDa, respectively (Figure 3). Higerd and Spizizen (1973) also reported two acetyl esterases from *B. subtilis* 168 extracts. By employing gel filtration chromatography, the estimated molecular weights for these esterases, named A and B, are 160,000 and 51,000, respectively. Finally, no significant difference was detected between the hydrolytic activities of the both whole cell biocatalysts tested. However, the supernatant activity obtained from *Bacillus* sp. A60 almost doubled that obtained from reference *B. subtilis* 1A571 (Table 3).

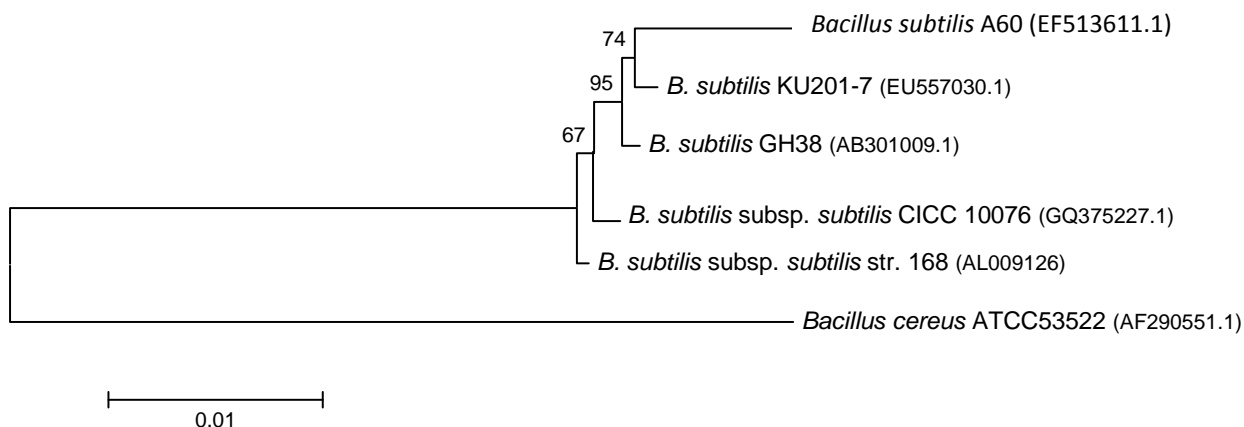

Figure 2. Neighbor-joining phylogenetic tree of partial 16S rDNA sequences. The method of Jukes and Cantor was used to calculate evolutionary distances, and tree topology was constructed using MEGA 4. Bootstrap values ($n = 1000$ replicates) were indicated at the nodes. Scale bar represents observed number of changes per nucleotide position. In parenthesis, accession numbers of the reference strains 16S rDNA sequences.

Table 3. Comparison of hydrolytic and synthetic activities from supernatant and whole cells between *Bacillus* sp. A60 and the reference strain *B. subtilis* 1A571.

Reaction	Biocatalyst	<i>Bacillus</i> sp. A60	<i>B. subtilis</i> 1A571
Hydrolysis (U/mg)	Supernatant	2.67 ± 0.11 (a)	1.62 ± 0.08 (b)
	Whole cell	7.07 ± 0.09 (a)	6.94 ± 0.75 (a)
Synthesis (% conversion)	Supernatant	88 ± 0 (a)	74.5 ± 0.35 (b)
	Whole cell	55.58 ± 0.78 (a)	66.47 ± 0 (b)

Values across lines followed by the same letters do not differ significantly ($p < 0.05$).

Synthetic reactions catalyzed by culture supernatants and whole cells

One of the process for producing ethyl acetate is by esterification of ethanol with acetic acid. As shown in Table 3, enzymatic esterifications of ethanol with acetic acid in n-hexane using several biocatalysts preparations were investigated. The immobilized supernatant of *Bacillus* sp A60 had a better performance (88.0% of conversion) than that of *B. subtilis* 1A571 (74.50% of conversion) ($p < 0.0001$). In contrast, whole cells of *B. subtilis* 1A571 showed a higher level of conversion (66.47%) than those of *Bacillus* sp. A60 (55.58%). In addition, the TLC profiles of synthetic reactions showed a new spot that could correspond to the ethyl acetate production (data not shown). It is interesting to note that although a high tolerance towards organic solvents has been described for *B. subtilis* 168 (Kataoka et al., 2011), the proposed biotransformation catalyzed by either immobilized supernatant or whole cells from *B. subtilis* 1A571 constitutes an important contribution to the knowledge of this reference strain.

Concerning the enzymatic synthesis of ethyl acetate, the conversions obtained in this work were similar to or higher than those reported in some chemical processes

such as the ethanol dehydrogenation to ethyl acetate by using copper and copper chromite (Santacesaria et al., 2012) or Cu-Zn-Zr-Al-O (Inui et al., 2004) as catalysts.

Effect of medium components on *Bacillus* sp. A60 growth and hydrolytic esterase production

Esterase production requires complex nitrogen and carbon sources and its appropriate type and concentration differ from organism to organism (Kademi et al., 1999). To efficiently utilize *Bacillus* sp. A60 as a biocatalyst, high biomass density and high esterase activity would be necessary. In our assays, the concentrations of the components of LB medium were varied in order to determine any effect on either growth or hydrolytic esterase activity produced by *Bacillus* sp. A60. As shown in Figure 4, the nutrient media composition strongly affected both growth and enzyme activity under study. As expected, the LB medium represented the right proportions for growth. Concerning the extracellular esterase production, it was increased as the concentration of either tryptone or yeast extract increased. Others authors have obtained similar results, where tryptone and yeast extract act as enhancers for esterase and lipase production, without a growth

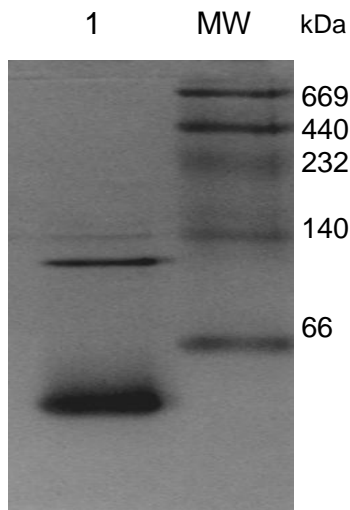

Figure 3. Native-PAGE using 10 % polyacrylamide gel revealed for esterase activity. Lane 1, *Bacillus* sp. A60 supernatant; MW, molecular weight maker.

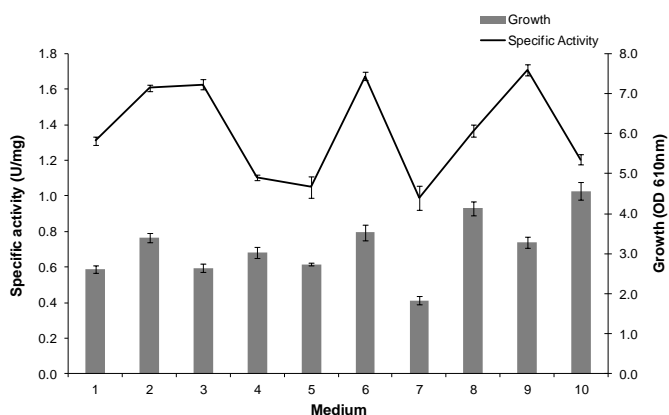

Figure 4. Effect of medium components on *Bacillus* sp. A60 growth and hydrolytic esterase production.

correlation (Kademi et al., 1999; Mimura and Nagata, 1998). Under our assay conditions, the effect of yeast extract was the most notorious; its absence meant slower growth and lower esterase hydrolytic activity. Adding yeast extract involved the recovery of both parameters, especially the esterase hydrolytic activity. On the other hand, according to its halotolerant condition, the presence of NaCl influenced positively on the production of the esterase activity. This is an interesting issue, since high concentration of NaCl could have an effect of thermal protection, as described for *Brevibacterium* sp. (Mimura and Nagata, 1998). For these reasons it is possible to improve the esterase activity of *Bacillus* sp. A60 by selecting appropriate concentration of the culture medium. These results combined with the previous ones prove the

potential utility of esterases from *Bacillus* sp. A60 with a great application in food and chemical industries.

ACKNOWLEDGEMENT

This work was supported by grants PICT 2011-2158 (FONCyT), CIUNT 26/D409(UNT) and PIP 297 (CONICET).

REFERENCES

- Alvarez-Macarie E, Baratti J (2000). Short chain flavour ester synthesis by a new esterase from *Bacillus licheniformis*. J. Mol. Catal. B Enzym. 10: 377-383.
- Ateslier ZBB, Metin K (2006). Production and partial characterization of a novel thermostable esterase from a thermophilic *Bacillus* sp. Enzyme Microb. Tech. 38:628-635.
- Baigori M, Castro GR, Siñeriz F (1996). Purification and characterization of an extracellular esterase from *Bacillus subtilis* MIR-16. Biotechnol. Appl. Biochem. 24: 7-11.
- Bélafi-Bakó K, Kabiri Badr A, Nemestóthy N, Erenstein U, Gubicza L (2003). Kinetics of ethyl acetate formation by lipase in organic solvent and solvent-free system. Chem. Pap. 57: 278-281.
- Bornscheuer UT (2002). Microbial carboxyl esterases: classification, properties and application in biocatalysis. FEMS Microbiol. Rev. 26: 73-81.
- Bradford MM (1976). A rapid and sensitive method for the quantitation of microgram quantities of protein utilizing the principle of protein-dye binding. Anal. Biochem. 72: 248-254.
- Davis BJ (1964). Disc electrophoresis. II. Method and application to human serum proteins. Ann. N. Y. Acad. Sci. 121: 404-247.
- Garrity GM, Bell JA, Lilburn TG (2005). Taxonomic Outline of the Prokaryotes: Bergey's Manual of Systematic Bacteriology. Doi No. <http://dx.doi.org/10.1007/bergeysoutline>. Published online by Springer-verlag, New York.
- Hanefeld U, Gardossi L, Magner E (2009). Understanding enzyme immobilization. Chem. Soc. Rev. 38: 453-468.
- Harwood CR, Wipat A (1996). Sequencing and functional analysis of the genome of *Bacillus subtilis* strain 168. FEBS Lett. 389: 84-87.
- Higerd TB, Spizizen J (1973). Isolation of two acetyl esterases from extracts of *Bacillus subtilis*. J. Bacteriol. 114: 1184-1192.
- Inui K, Kurabayashi T, Sato S, Ichikawa N (2004). Effective formation of ethyl acetate from ethanol over Cu-Zn-Zr-Al-O catalyst. J. Mol. Catal. A Chem. 216: 147-156.
- Jukes TH, Cantor CR (1969). Evolution of protein molecules. In Munro HN, editor, *Mammalian Protein Metabolism*, pp. 21-132, Academic Press, New York.
- Kademi A, Fakhreddine L, Ait-Abdelkader N, Baratti JC (1999). Effect of culture conditions on growth and esterase production by the moderate thermophile *Bacillus circulans* MAS2. J. Industrial Microbiol. Biotechnol. 23: 188-193.
- Kataoka N, Tajima T, Kato J, Rachadech W, Vangnai AS (2011). Development of butanol-tolerant *Bacillus subtilis* strain GRSW2-B1 as a potential bioproduction host. AMB Express 1:10.
- Lindgren V, Rutberg L (1974). Glycerol metabolism in *Bacillus subtilis*: gene-enzyme relationships. J. Bacteriol. 119: 431-442.
- Miller JH (1972). Experiments in molecular genetics. Cold Spring Harbor Laboratory, Cold Spring Harbor, NY.
- Mimura H, Nagata S (1998). Effect of hyper-salt stress on the heat resistance of a halotolerant *Brevibacterium* sp. JCM6894. J. Ferment. Bioeng. 85: 185-189.
- Panda T, Gowrishankar BS (2005). Production and applications of esterases. Appl. Microbiol. Biotechnol. 67: 160-169.
- Romero CM, Pera LM, Loto F, Vallejos C, Castro G, Baigori MD (2012). Purification of an organic solvent-tolerant lipase from *Aspergillus niger* MYA 135 and its application in ester synthesis. Biocatal. Agric. Biotechnol. 1: 25-31.
- Santacesaria E, Carotenuto G, Tesser R, Di Serio M (2012). Ethanol dehydrogenation to ethyl acetate by using copper and copper chromite catalysts. Chem. Eng. J. 179: 209-220.

Schallmey M, Singh A, Ward O (2004). Developments in the use of *Bacillus* species for industrial production. *Can. J. Microbiol.* 50: 1-17.

Stergiou P, Foukis A, Filippou M, Koukouritaki M, Parapouli M, Theodorou L, Hatziloukas E, Afendra A, Pandey A, Papamichael E M (2013). Advances in lipase-catalyzed esterification reactions. *Biotechnol. Adv.* <http://dx.doi.org/10.1016/j.biotechadv.2013.08.006>.

Torres S, Baigorí MD, Swathy SL, Pandey A, Castro GR (2009). Enzymatic synthesis of banana flavour (isoamyl acetate) by *Bacillus licheniformis* S-86 esterase. *Food Res. Int.* 42:454-460.