

*Full Length Research Paper*

## Domestic wastewater treated for agricultural reuse

José Tavares de Sousa<sup>1</sup>, Rita de Cássia Vieira Alves<sup>2</sup>, Wilton da Silva Lopes<sup>3\*</sup>, Valderi Duarte Leite<sup>3</sup> and José Lima de Oliveira Júnior<sup>4</sup>

<sup>1</sup>Departamento de Engenharia Sanitária e Ambiental, Centro de Ciências e Tecnologia –  
Uganda Export Promotion Board (UEPB), Brazil.

<sup>2</sup>Mestre em Ciência e Tecnologia Ambiental – UEPB, Brazil.

<sup>3</sup>Departamento de Engenharia Sanitária e Ambiental, Centro de Ciências e Tecnologia –UEPB, Brazil.

<sup>4</sup>Departamento de Engenharia Sanitária e Ambiental, Instituto Federal do Ceará – campus Juazeiro do Norte, Brazil.

Accepted 22 June, 2012

Four post-treatment systems of an upflow anaerobic sludge blanket (UASB) reactor were evaluated regarding chemical and sanitary qualities. At an experimental station for biological treatment of sewage (EXTRABES) located in Campina Grande - PB, Brazil, the physical, chemical and biological parameters of the effluents from a UASB reactor and its post-treatment systems were monitored for two years. A baffled anaerobic filter (AF), a horizontal gravel bed (GB); a constructed wetland (CW) and a series of five polishing ponds were the systems used to treat the UASB reactor effluent. The chemical oxygen demand (COD) data in the post-treatment effluents ranged from 60 to 80 mg.L<sup>-1</sup>, which means a good efficiency in organic matter removal, exception made for polishing ponds (PP) (155 mg.L<sup>-1</sup>) due to the algal growth. The greater nutrient removal was observed in the CW, which can be explained by the presence of the macrophytes. Concerning pathogens occurrence there is not a significant difference between the AF and the CW effluents, both with appropriate concentrations for restricted reuse. Only the PP had concentrations less than 10<sup>3</sup> CFU.100 ml<sup>-1</sup>, the maximum value determined by the World Health Organization for unrestricted reuse. The helminthes eggs were efficiently removed into all analyzed treatments. The UASB was efficient in terms of organic matter and solids removal, favoring all post-treatment systems.

**Key words:** Domestic wastewater treatments, sanitary quality, reuse.

### INTRODUCTION

Urban population growth and their new habits in the last two decades have increased good quality water consumption and the domestic sewage discharge into water

bodies. There are few efforts in preservation of the worldwide water resources. This preservation is a real need.

Besides global irregular water distribution and pipe system losses, there is lack of sewage treatments, mainly in northeast Brazil. The use of lower quality water in agriculture, such as sewage treatments effluent, preserves water's good quality, avoids waterborne diseases, recycles nutrients, saves chemical fertilizers, expands irrigated areas, promotes recovery of degraded or unproductive areas and minimizes sewage discharge into surface water and its contamination and eutrophication impacts.

Parasites are often present in domestic sewage, which

\*Corresponding author. E-mail: [wilton@uepb.edu.br](mailto:wilton@uepb.edu.br).

**Abbreviations:** AF, Anaerobic filters; CW, constructed wetland; GB, gravel bed; PP, polishing ponds; UASB, upflow anaerobic sludge bed reactor; COD, chemical oxygen demand; TKN, total Kjeldahl nitrogen; TTC, thermotolerant coliforms; VSS, volatile suspended solids; HRT, hydraulic retention time; COD, chemical oxygen demand.

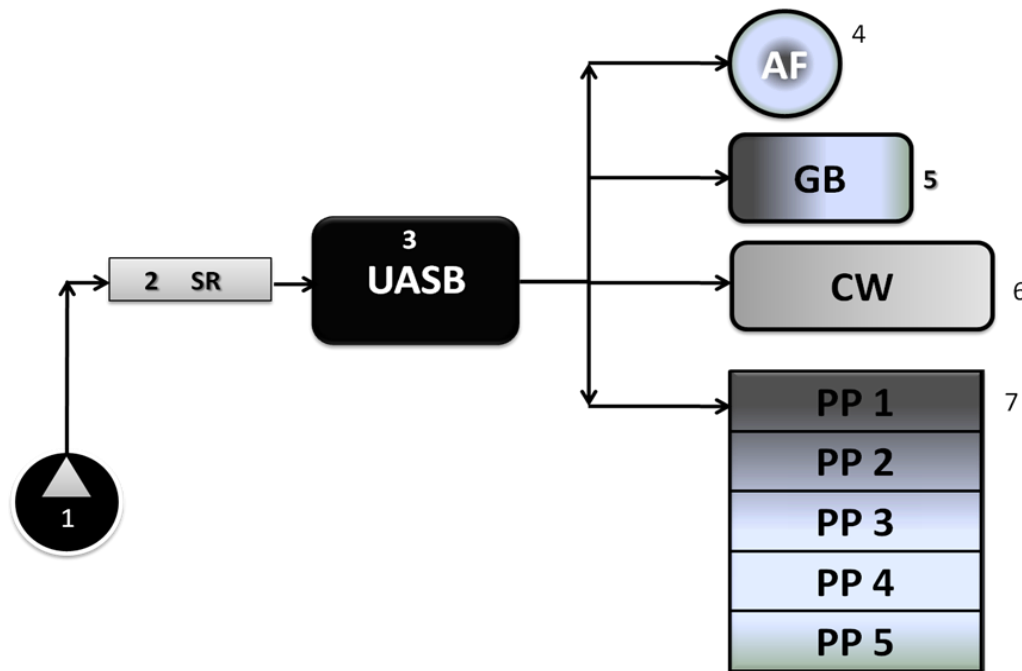

**Figure 1.** Treatment sewage system's layout. (1) Submersible pump; (2) Sand retention; (3) UASB reactor; (4) Anaerobic filter (AF); (5) Gravel bed (GB); (6) Constructed wetlands (CW); (7) Polishing ponds ((PP).

can result to contaminated food or waterborne diseases as may be the case of irrigation of raw-eaten vegetables with untreated sewage, representing a real public health risk (WHO 1989; WHO, 2006).

There are great amount and variety of pathogenic organisms and high toxicity chemical constituents present in sewage. So, the possibility of disease transmission is of major concern in reuse, demanding an adequate treatment to comply with the quality criteria (WHO, 2006; USEPA, 2004). Despite the difficulties associated with the required care of the sewage, using treated wastewater in agriculture is an alternative for water resources management. It allows economy of good quality water as well as, mitigation of water bodies' contamination.

To find the best treatment of sewage that will comply with the quality irrigation guidelines, a study was carried out comparing the use of a anaerobic filters (AF), a constructed wetland (CW), a gravel bed systems (GB) and a polishing ponds (PP) as post-treatments for an upflow anaerobic sludge bed reactor (UASB) effluent producing wastewater with chemical and sanitary characteristics for restricted and unrestricted irrigations.

## MATERIALS AND METHODS

### Location and design of the experimental system

The research was conducted in Biological Treatment Station for

Sewage (EXTRABES), located in the City of Campina Grande (7° 13' 11" South, 35° 52' 31" West, 550 m above sea level), Paraíba state, northeastern Brazil.

The raw sewage was pumped by a submersible pump from the interceptor pipe of Water and Sewage Company of Paraíba State (CAGEPA) to a reservoir of 1,000 liters, flowing by gravity to a second box of 1,000 liters by a peristaltic metering pump with a flow rate of 20 m<sup>3</sup>. day<sup>-1</sup>, feeding the UASB reactor. The experiment consisted of a 5 m<sup>3</sup> fiberglass UASB with hydraulic retention time (HRT) of six hours to be post-treated in four different units:

1. Anaerobic filter (AF) built in fiberglass with 1.00 m<sup>3</sup> capacity and HRT of seven days.
2. Polishing ponds (PP) of 10.00 m long, 1.00 m wide and 0.60 m deep with HRT of twelve days.
3. Gravel bed (GB) with an area of 10.00 m<sup>2</sup> (1.00 m wide by 10.00 long), filled by gravel with 19 to 49% of void index and HRT of seven days.
4. Constructed wetlands (CW), with the characteristic of the previous system, differing on a set of 15.00 m<sup>2</sup> of macrophyte *Juncus* sp plantation. Figure 1 schematically shows the treatment system, while Table 1 shows the operational features.

### Samples and analysis

Analyses were performed weekly for all systems effluents. The parameters analyzed were chemical oxygen demand (COD), total solids, volatile total solids, suspended solids, volatile suspended solids, total Kjeldahl nitrogen (TKN) and ammonia, orthophosphate, total phosphorus and thermotolerant coliforms (TTC) complying with the recommendations of the standard methods for the examination of wastewater (APHA, 1995).

Sanitary evaluation was carried out weekly for thermotolerant

**Table 1.** Operational and physical characteristics of experimental systems.

| Characteristic                                  | UASB   | AF    | CW        | GB         | PP    |
|---|--------|-------|-----------|------------|-------|
| Usable volume (m <sup>3</sup> )                 | 5.00   | 1.00  | 2.28      | 2.94       | 30.00 |
| HRT (days)                                      | 0,21   | 7.00  | 7.00      | 7.00       | 12.00 |
| Flow rate (L/day)                               | 20,000 | 143   | 325       | 420        | 90    |
| Support media                                   | -      | PET   | Grit Sand | Gravel (*) | -     |
| OLR (kg COD.m <sup>3</sup> .Day <sup>-1</sup> ) | 2.24   | 0.029 | 0.029     | 0.029      | 0.017 |
| Substrate void index (%)                        | -      | 94    | 37        | 49         | -     |

UASB, Up flow anaerobic sludge blanket; AF, anaerobic filter; GB, gravel bed; PP, polishing pond; CW, constructed wetland; (\*), 19 mm diameter.

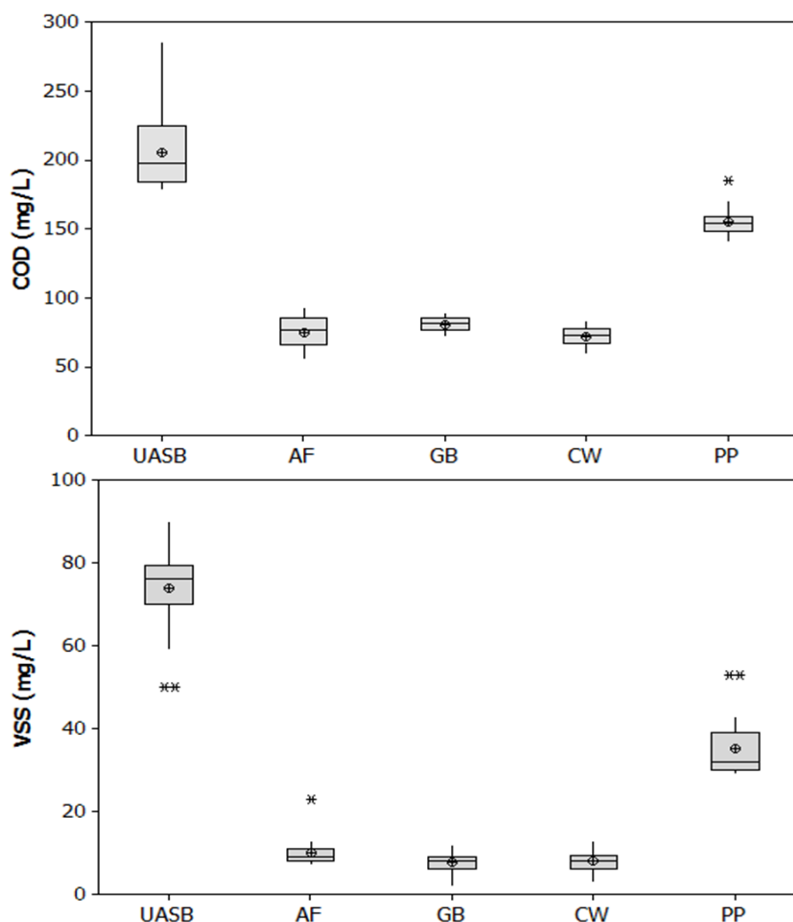
**Figure 2.** Effluent COD (left) and VSS (right) average values.

coliforms and biweekly for helminthes eggs. The TTC were analyzed by membrane filtration method (APHA, 1995) with incubation at  $44.5^{\circ}\text{C} \pm 0.5$  for 24 h using m-FC medium (Difco) and the (Bailenger, 1996) method for helminthes eggs (WHO, 1989). The parameters were statistically analyzed, estimating the dispersion measures and central tendency throughout three statistical methods:

(1) Statistics descriptive distribution (Box Plot), (2) analysis of variance (ANOVA) of single factor with significance level of 5% and (3) GT-2 method (Sokal and Rohlf, 1981).

## RESULTS

Figure 2 presents in Box Plot the lower and upper limits and the average values of effluent COD and volatile suspended solids (VSS). The COD in UASB effluent had an average of  $200 \text{ mg O}_2 \cdot \text{L}^{-1}$ . Results also shows organic matter removal efficiency of 64%. In turn, the AF's effluent COD presented an average of  $75 \text{ mg O}_2 \cdot \text{L}^{-1}$  with no significant difference between the organic matter for

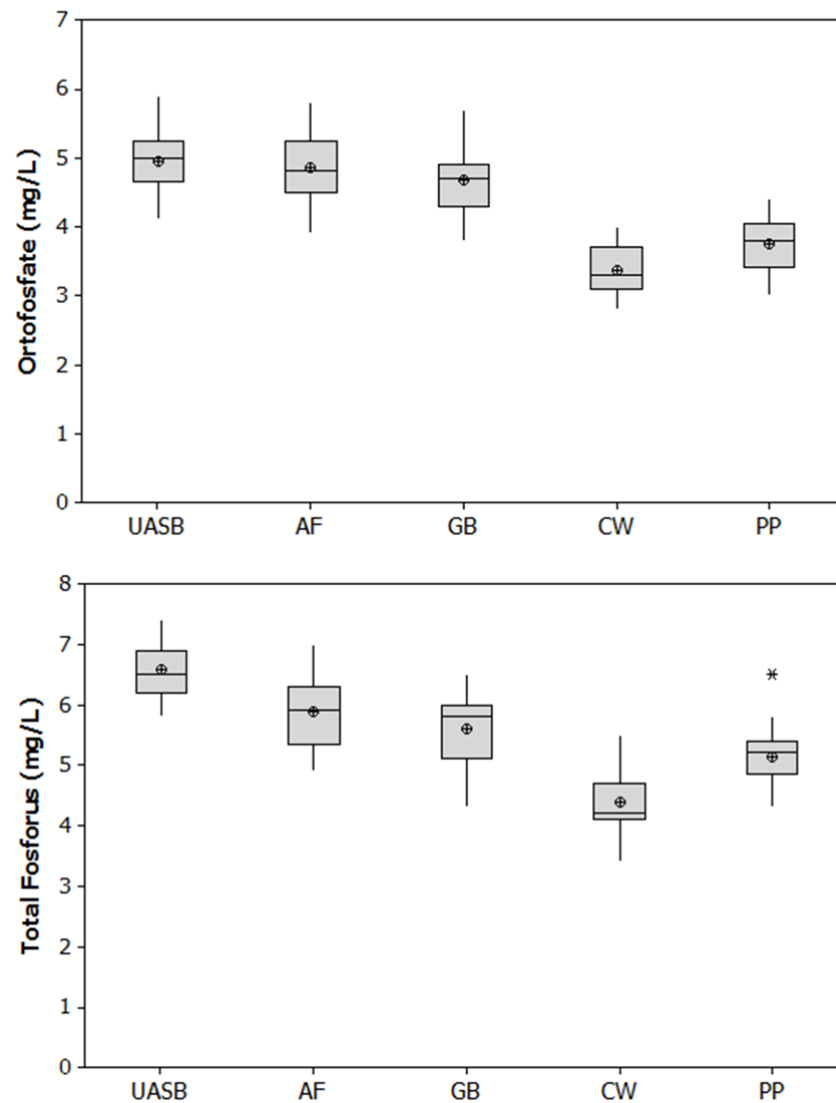

**Figure 3.** Total effluent Phosphorus (left) and Orthophosphate (right) average.

AF and CW though a little advantage due to macrophytes removing COD and VSS had been observed. The CW produced effluent with average of 70 mg O<sub>2</sub>. L<sup>-1</sup> and 10 mg SSV. L<sup>-1</sup>. The PP effluent average remained on 155 mg O<sub>2</sub>. L<sup>-1</sup> and 35 mg SSV. L<sup>-1</sup> because of the significant algae production.

Figure 3 shows the mean values for total phosphorus and orthophosphate. The UASB and AF effluent average of total phosphorus were 6.6 and 5.9 mg P.L<sup>-1</sup> respectively. In turn, the GB and CW effluent remained with an average of 5.6 and 4.4 mg P.L<sup>-1</sup>. For PP effluent the average was 5.1 mg P.L<sup>-1</sup>.

The orthophosphate average for UASB and AF effluent was 4.9 and 4.8 mgP-PO<sub>4</sub><sup>-3</sup> L<sup>-1</sup> respectively, while GB and CW effluents remained with average values around 4.7 and 3.4 mg P-PO<sub>4</sub><sup>-3</sup> L<sup>-1</sup>. Similar results were obtained

by Ghunmi et al. (2010), with no significant decrease after anaerobic treatment.

Figure 4 shows the average ammonia and TKN in effluent. The TKN in UASB maintained an average of 53 and 34 mg N-TKN.L<sup>-1</sup> for AF. The GB results remained around 25 mg N-TKN.L<sup>-1</sup>. The average for PP and CW was 20 and 23 mg N-TKN.L<sup>-1</sup>, respectively. Some considerations were made so that the amount of available organic matter (COD) and nutrients (NPK) in the treated effluent could be estimated. Most of the subsistence crops at Brazilian semi-arid has a 100 days vegetative cycle and has a good productivity with an annual precipitation average of 600 mm well distributed rain.

Since 1 mm rain means a 10 m<sup>3</sup>/ha, the volume of water is 6,000 m<sup>3</sup> per hectare per crop cycle. Considering

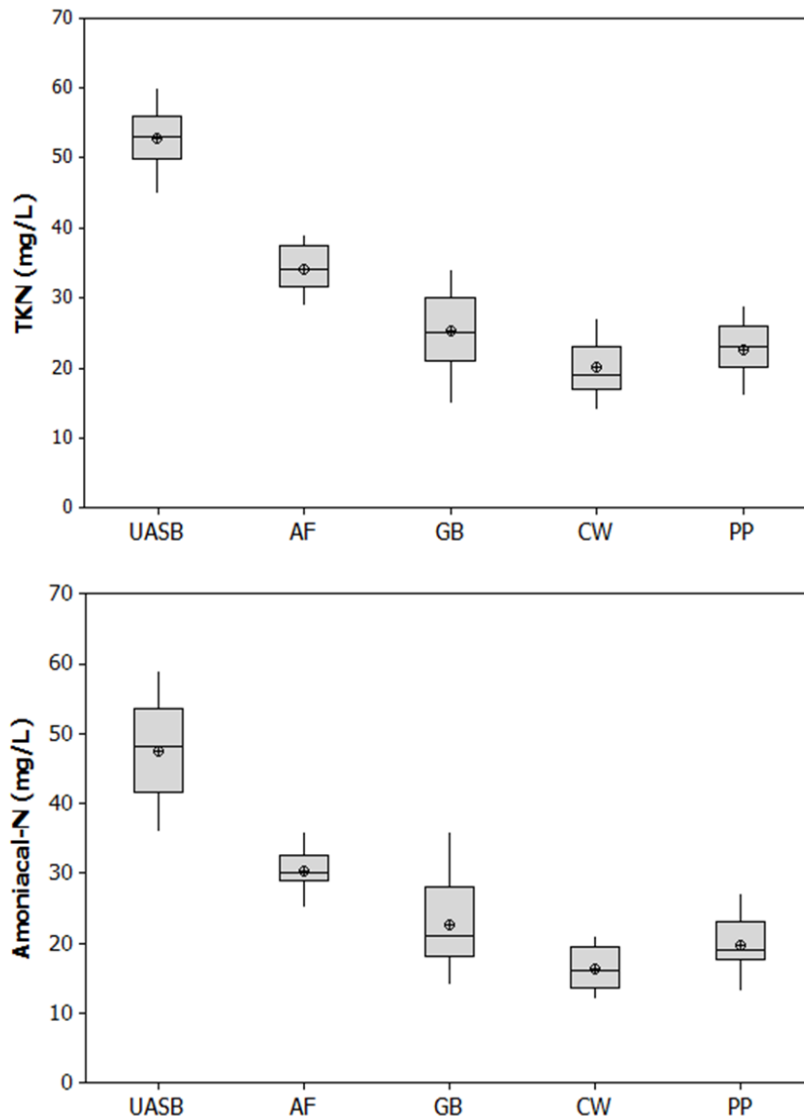

Figure 4. Effluent TKN (left) and Ammonia concentration (right) averages.

Table 2. Estimated mean values of COD and NPK in effluent for regional crop growth cycle of 100 days.

| System | COD (kg/ha) | N (kg/ha) | P <sub>2</sub> O <sub>5</sub> (kg/ha) | K <sub>2</sub> O (kg/ha) |
|--------|-------------|-----------|---------------------------------------|--------------------------|
| UASB   | 1230        | 317       | 40                                    | 140                      |
| AF     | 450         | 204       | 31                                    | 143                      |
| GB     | 480         | 150       | 33                                    | 142                      |
| CW     | 432         | 120       | 27                                    | 141                      |
| PP     | 930         | 135       | 33                                    | 145                      |

for example, the effluent of the AF in Figure 4, the available NPK would be of  $6,000 \text{ m}^3 \times 34 \text{ g/m}^3 = 204 \text{ kg / ha}$  per cycle, as shown in Table 2. Similar values were obtained by Vazquez-Montiel (Vazquez-Montiel, 1996).

Table 3 presents the sanitary quality parameters for raw sewage and effluent. The concentration of TTC remained at the same order of magnitude between  $3.2$  and  $8.3 \times 10^3 \text{ CFU.100 ml}^{-1}$ . Only the PP effluent showed a

**Table 3.** Average values of thirty determinations of thermotolerant coliform and helminthes eggs analysis.

| TTC (CFU. 100 mL <sup>-1</sup> )             | (RW)                | Effluent thermotolerant coliforms concentration |                     |                     |                     |                     |
|--|---------------------|---|---------------------|---------------------|---------------------|---------------------|
|  |                     | UASB  | PP                  | AF                  | GB                  | CW                  |
| Geometric Mean                               | 3.1x10 <sup>7</sup> | 8.5x10 <sup>6</sup>                             | 9.8 10 <sup>2</sup> | 3.2x10 <sup>3</sup> | 1.8x10 <sup>3</sup> | 8.4x10 <sup>3</sup> |
| Median                                       | 4.1x10 <sup>7</sup> | 8.8x10 <sup>6</sup>                             | 8.0x10 <sup>2</sup> | 1.5x10 <sup>3</sup> | 5.4x10 <sup>3</sup> | 6.1x10 <sup>3</sup> |
| Maximum                                      | 8.2x10 <sup>7</sup> | 1.9x10 <sup>7</sup>                             | 1.2x10 <sup>3</sup> | 4.1x10 <sup>4</sup> | 8.3x10 <sup>3</sup> | 3.7x10 <sup>4</sup> |
| Minimum                                      | 8.9x10 <sup>6</sup> | 8.9x10 <sup>5</sup>                             | 2.9x10 <sup>2</sup> | 1.0x10 <sup>3</sup> | 3.1x10 <sup>3</sup> | 3.4x10 <sup>3</sup> |
| <b>Helminthes eggs (eggs.L<sup>-1</sup>)</b> |                     |   |                     |                     |                     |                     |
| Arithmetic mean                              | 230                 | 160   | ND                  | ND                  | ND                  | ND                  |
| Maximum                                      | 250                 | 180   | ND                  | ND                  | ND                  | ND                  |
| Minimum                                      | 118                 | 40  | ND                  | ND                  | ND                  | ND                  |

AF, Anaerobic filter; GB, gravel bed; CW, constructed wetland; PP, polishing ponds. ND, not detected.

**Table 4.** Single factor ANOVA and GT-2 method in monitored systems.

| Parameter          | ANOVA                  | GT-2* |    |    |    |
|--------------------|------------------------|-------|----|----|----|
|                    | p-value                | AF    | GB | CW | PP |
| COD                | 2.83x10 <sup>-59</sup> | ab    | b  | a  | c  |
| VSS                | 4.08x10 <sup>-45</sup> | a     | a  | a  | b  |
| pH                 | 4.16x10 <sup>-38</sup> | a     | b  | b  | c  |
| TKN                | 3.16x10 <sup>-21</sup> | a     | b  | c  | bc |
| Ammoniacal-N       | 4.36x10 <sup>-21</sup> | a     | b  | c  | b  |
| Total Phosphorus   | 1.36x10 <sup>-15</sup> | a     | ab | c  | b  |
| Orthophosphate     | 1.04x10 <sup>-23</sup> | a     | a  | b  | c  |
| TTC <sup>(1)</sup> | 7.36x10 <sup>-10</sup> | a     | a  | a  | b  |

\*, Treatments followed by same letter do not differ significantly ;<sup>(1)</sup> –thermotolerant coliforms.

pathogens removal average of 9.80 x 10<sup>2</sup> CFU/100ml<sup>-1</sup> as recommended by WHO (2006) for restricted irrigation. Table 4 shows p-value using analysis of variance with single factor, besides GT-2 results to identify difference among monitored systems. The organic matter, represented by COD and VSS concentration of AF, GB and CW effluents was similar, although the COD of GB effluent showed significant difference comparing with CW's, while the effluent SSV of the three systems showed no differences between themselves.

Variation appeared in organic matters values for PP, with an average of 155 mgO<sub>2</sub> .L<sup>-1</sup> for COD, nearly twice the value of the other systems that were 75, 80 and 72 mgO<sub>2</sub> .L<sup>-1</sup> for the AF, GB and CW, respectively.

## DISCUSSION

### Organic matter

The effluent organic matter was measured as COD and

VSS. The domestic wastewater pretreatment in the UASB reactor has produced effluent concentrations of 75 mg.L<sup>-1</sup> SSV and 205 mg.L<sup>-1</sup> COD (Figure 2), which is consistent with the results obtained by Chernicharo (2007). With an efficiency of 66% for SSV and 64% for DQO, the UASB can substitute the anaerobic stabilization ponds in domestic wastewater pretreatment. This exchange turns easier to operate the system, reduces the HRT and increases the amount of treated effluent per unit area (Cavalcanti, 2003). The effluents from AF, GB and CW had relative low COD, from 70 up to 80 mgO<sub>2</sub> .L<sup>-1</sup> (Figure 2). The PP produced an effluent with average COD of 155mgO<sub>2</sub>.L<sup>-1</sup>, similar to results from von Sperling (2005). The COD in these effluents are stabilized, improving its water retention when applied to the soil, also favoring soil's cations exchange and buffering capacity.

According to Lado et al. (2009) irrigation with COD values higher than those found in this research in arid and semiarid regions, may cause soil imbalance because

of excess seepage reducing the saturated hydraulic conductivity and altering soils chemical properties

### Nutrients in phosphorus and nitrogen forms

The post-treatment units of anaerobic effluent presented concentrations ranging from 4 to 3.4 mg P-PO<sub>4</sub><sup>-3</sup>.L<sup>-1</sup>. Similar values were observed by Sousa et al. (2009). These phosphorus concentrations are desirable for agricultural irrigation, given the importance to the respiratory and photosynthetic metabolism. Associated with the available organic matter, phosphorus promotes humification buffering in irrigated soil, although its excess may cause eutrophication. Ammonia, on the other hand, stimulates plant growth and is important in agricultural wastewater reuse been its excess a cause for inhibition or even deterioration of plants growth (Malavolta et al., 2002).

The ammonia-N concentrations in post-treatment units still remained high. The CW effluent remained on average 20 mg NH<sub>4</sub>-N.L<sup>-1</sup>. Plants use nitrogen in the form of ammonium and nitrate ion. Vegetables eaten raw, which are fragile species, may tolerate 5 mg NH<sub>4</sub>.L<sup>-1</sup>, although most of them are not affected in the range of 30 mg NH<sub>4</sub>-N.L<sup>-1</sup> (Ayers and Westcot, 1991). The anaerobic treatments used in this study are an advantage since it does not remove nutrients. The main macro nutrients contained in sewage are phosphorus, potassium and nitrogen (Metcalf and Eddy, 2003).

Nitrogen data in Table 2 shows a variation from 204 to 120 kg N . ha<sup>-1</sup> Per Cycle. This concentration may be sufficient for some crops, for example, a grass irrigation during summer season applied in soils with organic matter content of 2.5%, which according Malavolta et al. (2002), would need fertilizer around 200 kg N / ha per cycle.

### Sanitary quality of produced effluent prior to agricultural reuse

The effluents data showed significant differences in terms of thermotolerant coliforms, as stated in Table 3. Among those investigated treatment units, only the final PP effluent had an average concentration lower than 1,000 CFU/100 mL<sup>-1</sup> (Table 3) which can be used for unrestricted irrigation (WHO, 2006).

For helminthes eggs evaluation, Table 3 shows high concentration in UASB reactor effluent which does not meet any WHO standards for reuse. The post-treatment systems achieved 100% efficiency in removing helminthes, reaching sanitary quality standards ( $\leq 1$  egg / L) from WHO (2006). The *Ascaris* eggs removal occurred at discrete settling in ponds monitored with hydraulic surface load of 0.22 m.day<sup>-1</sup>. Similar results were found

by Cavalcanti (2003).

### Conclusion

The effluents produced in shallow PP with HRT of twelve days, had good sanitary quality for irrigation, with TTC less than 10<sup>3</sup> CFU/mL, and free of helminthes eggs. However, due to high pH values, between 8.0 and 8.8, there was considerable phosphorus and nitrogen removal, providing fewer nutrients for irrigation. These ponds with a depth of 0.60 m require more area, which is a negative aspect economically, especially in large cities, though the effluent has met the requirements for unrestricted irrigation.

The organic matter removal as COD was considerable, with no significant differences ( $p > 0.05$ ) between systems, except for PP effluent, probably due to high COD, which was greater than 100 mg. L<sup>-1</sup> because of algae growth. The effluent coming from CW had a lower concentration of nutrients due to the removal performed by macrophytes. However, for GB effluent, nutrient removal showed no significant difference ( $p > 0.05$ ).

Post-treatment of UASB effluent in AF with an HRT of seven days produced effluent without helminthes eggs, but the concentration of TTC remained with magnitude order greater than 10<sup>4</sup> CFU/100 mL. Thus, these effluents require another post - treatment to make it suitable for unrestricted irrigation (WHO, 2006).

### ACKNOWLEDGEMENT

The authors thank CNPq for research funding and productivity grants.

### REFERENCES

- Apha AWWA, (1995). Standard methods for the examination of water and wastewater. 15 ed. Washington, D.C.: American Public Health Association. American Water Works Association, Water Pollution Control Federation, p. 953.
- Ayers RS, Westoot DWA (1999). Quality of water in agriculture (Water quality for agriculture). Trad. Gheyi H. Medeiros JF; Damasceno FV, Campina Grande, UFPB, p. 218.
- Bailenger J (1996). Mechanisms of parasitological concentration in coprology and their practical consequences. J. Am. Med. Technol. 41 *apud* Ayres R & Mara D. Analysis of wastewater for use in agriculture. A laboratory manual of parasitological and bacteriological techniques. Geneva: WHO, pp. 65-71.
- Cavalcanti PFF (2003). Integrated application of the UASB reactor and ponds for domestic sewage treatment in tropical regions. Doctoral Thesis. Wageningen Agricultural University Wageningen, Netherlands, p. 139.
- Chernicharo CAL (2007). Anaerobic reactors: Principles of biological treatment of wastewater. (Anaerobic Reactors: Biological Wastewater treatment Principles) DESA/UFMG. Belo Horizonte-MG, 2:5-380.
- Ghunmi LA, Zeeman G, Fayyad M, van Lier JB (2010). Grey water

- treatment in a series anaerobic – Aerobic system for irrigation. *J. Bioresour. Technol.* 101:41-50
- Lado M, Ben-Hur M (2009). Treated domestic sewage irrigation effects on soil hydraulic properties in arids and semiarid zones: A review. *J. Soil Tillage Res.* p. 12.
- Malavolta E, Pimentel-Gomes F, Alcarde JC (2002). Fertilizers and Fertilization. São Paulo-SP. D. Nobel: p. 200.
- Metcalf E (2003). Wastewater engineering: treatment, disposal and reuse. 2ed. New York. McGraw-Hill. p. 1815.
- Sokal RR, Rohlf FJ (1981). Biometry– The Principles and Practice of Statistic in Biological Research. 2nd edition. San Francisco: W.H. Freeman and Company. p. 634.
- Sousa JT , Lopes WS, Leite VD, Prasad S (2009). Treatment of Sewage for Use in the Agriculture. In: Anna Stephens; Mark Fuller. (Org.). Sewage Treatment: Uses, Processes and Impact. New York: Nova Publishers, pp. 123-154.
- USEPA (2004). United States Environmental Protection Agency. Guidelines for water reuse. U.S. Environmental Protection Agency. Washington DC, p. 217.
- Vasquez-Montiel O, Horan NJ, MARA DD (1996). Management of wastewater for reuse in irrigation. *J. Water Sci. Technol. Oxford* 33(10/11):355-362.
- Von Sperling M (2005). Principles of biological treatment of wastewater. Introduction to water quality and wastewater treatment. DESA / UFMG. Belo Horizonte-MG, 3:1-452.
- WHO (1989). Health Guidelines for the safe use of wastewater in agriculture and aquaculture. Technical Report Series 778. Geneva: World Health Organization. p. 72.
- WHO (2006). Guidelines for the safe use of wastewater, excreta and greywater: Wastewater Use in Agriculture. 2:630.